



TECH EXCHANGE

©2023 YAMAHA MOTOR CORPORATION, U.S.A.

SUBJECT: 2015 ~ 2021 YZF-R1 and YZF-R1M — Oil Strainer Cover Supersession

The 2015 ~ 2021 YZF-R1 and YZF-R1M Oil Strainer Cover has been changed due to procurement reasons. The magnesium Oil Strainer Cover is no longer manufactured and has been superseded to the current aluminum Oil Strainer Cover. As a result, when replacing the magnesium Oil Strainer Cover with the aluminum Oil Strainer Cover, the relating parts and service procedures will change. If the magnesium Oil Strainer Cover is ordered, it will automatically supersede to a kit part number once the current stock has been depleted. The superseded kit parts will include the new service procedures as well as all related parts.

Supersession Information:

	Previous	New
Part Name	Cover, Strainer	Strainer Cover Set
Part Number	2CR-13417-01-00	99999-04570-00
Quantity	1 pc	1 set

Superseded Kit Parts:

Kit Part Number	Kit Name	Components		
		Part Number	Part Name	QTY
99999-04570-00	Strainer Cover Set	B67-13417-00-00	Cover, Strainer	1
		BX4-13414-00-00	Gasket, Strainer Cover	1
		90110-06390-00	Bolt, Hexagon Socket Head	12
		-	Instruction Sheet	1

Part Identification:

The magnesium oil strainer cover has “2CR” printed on the surface.

The aluminum oil strainer cover has “B60” printed on the surface.

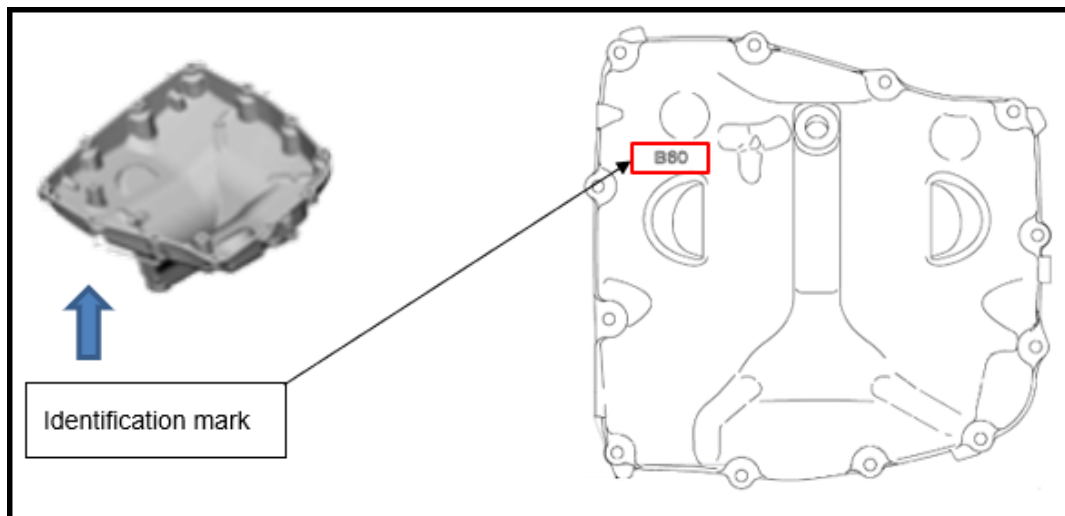

New Service Procedures for Superseded Kit Parts:

Due to the superseded kit parts being an aluminum oil strainer cover with steel bolts and steel oil strainer cover gasket, all 12 bolts will require Loctite® and be torqued to 10 Nm (1.0 kgf-m, 7.4 lb-ft).

INSTALLING THE OIL PAN

1. Install:

- Oil pan gasket **New**
- Oil pan
- Oil pan bolt (× 12)

The diagram shows the 12 bolt locations on the oil pan, numbered 1 through 12. The bolts are arranged in a circular pattern around the perimeter of the pan.

2. Tighten:

- Oil pan bolt

	Oil pan bolt
	10 N-m (1.0 kgf-m, 7.4 lb-ft)
	LOCTITE®