



Service Bulletin

Bulletin No.: 22-NA-083

Date: March, 2023

TECHNICAL

Subject: Requirements for Replacement of the Dual Mode Charge Cord Set Under Warranty

Brand:	Model:	Model Year:		VIN:		Propulsion:	Drive Unit:
		from	to	from	to		
Cadillac	LYRIQ	2023	2023	—	—	—	—
Chevrolet	Bolt EUV	2022					
GMC	HUMMER EV						

Involved Region or Country	North America Only
Condition	<p>When replacing the dual mode charge cord set under warranty, you must order the full cable kit. Do not order one or two of the individual components. Return all three customer components, (1) charge cord body, and (2) swappable grid plugs when the parts are requested by the GM Warranty Parts Center (WPC).</p> <p>Note: Failure to return all three components may result in a debit of the warranty claim.</p> <p>Charge cords are not to be replaced due to customer abuse or failure to comply with charge cord instructions.</p> <p>Many charge cords are returned without any trouble found. Additional information is appreciated on the repair order as to why the cord set is being replaced, such as the LED light status, which grid plug was being used, etc.</p>
Cause	The product quality team requests all three components be returned to perform proper root cause analysis on the returned assembly.
Correction	<p>Refer to SI procedures and other published bulletins to aid in cord set diagnosis for known customer induced issues prior to replacing the cord set under warranty.</p> <p>All charge cords are part of the Pre-Repair Authorization process for warranty repairs. Please refer to Service Bulletin # 18-NA-306 for the pre-repair authorization process.</p> <p>Note: Replacing a cord set for a customer induced condition may result in a debit of the warranty claim. Warranty coverage is for manufacturing defects.</p> <p>Note: The individual components are available to repair customer induced, non-warranty conditions.</p>

Important: Service agents must comply with all International, Federal, State, Provincial, and/or Local laws applicable to the activities it performs under this bulletin, including but not limited to handling, deploying, preparing, classifying, packaging, marking, labeling, and shipping dangerous goods. In the event of a conflict between the procedures set forth in this bulletin and the laws that apply to your dealership, you must follow those applicable laws.

Important: This technical service bulletin (TSB) can only be completed by certified repair facilities who have met all specific training, tool and equipment requirements pertaining to the vehicle Brand and Model serviced. Repairs must be performed by a technician who has successfully completed the required training.

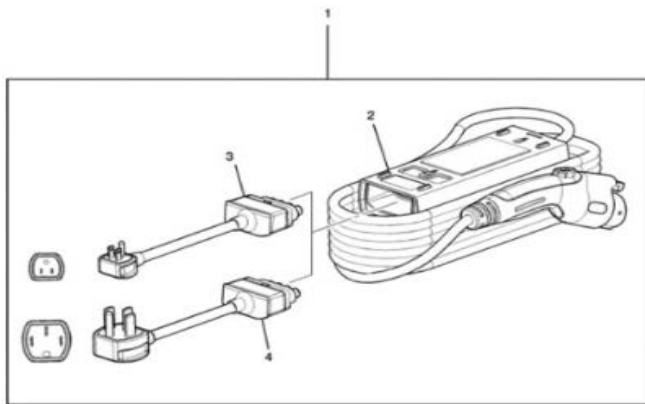

6045731

- 1. Cable Kit
- 2. Cord Set Body (Module)
- 3. 120v Plug
- 4. 240v Plug

Parts Information

Description	Part Number
BOLT EV/EUV - CABLE KIT (Includes cord body and both grid plugs)	85163382
ALL OTHER MODELS – CABLE KIT (Includes cord body and both grid plugs)	84878610
DO NOT REPLACE UNDER WARRANTY (Module)	24044913
DO NOT REPLACE UNDER WARRANTY (120v Plug)	24295528
DO NOT REPLACE UNDER WARRANTY (240v Plug)	24295536

Warranty Information

For vehicles repaired under warranty, use:

Important: Portable charge cords are covered under the new vehicle bumper-to-bumper warranty (Canada Base Warranty).

Labor Operation	Description	Labor Time
5040230	Drive Motor Battery Charger Cable Kit Replacement	Use Published Labor Operation Time

Version	2
Modified	Released April 19, 2022 Revised March 23, 2023 – Added Cadillac LYRIQ, 2023 Model Year, updated Condition, Correction and Parts Information.

