

# Special Bulletin

# SP22-314 CO 20

Date	Expiration	Release	Page
03.2023	03.2025	1	1(19)

First Release

03-17-2023

## CHANGE ORDER NO. 20 – 3-POINT ORANGE SEAT BELT INSTALLATION

Prevost vehicles

### DESCRIPTION

On the vehicles affected by this bulletin, install a driver seat orange belt in replacement of the black one.

### MODEL YEAR(S) AND VEHICLES INVOLVED

<b>NOTICE TO SERVICE CENTERS</b>			
<i>Verify vehicle eligibility by checking warranty bulletin status with <b>SAP</b> or via <b>ONLINE WARRANTY SYSTEM</b> available on Service / Warranty tab of Prevost website.</i>			
<b>Model</b>	<b>VIN</b>		
X3-45 Commuter Model Year: 2021 - 2023	4RKJ33493 <u>M9737919</u>	4RKJ33498 <u>P9738035</u>	DOB FLEET NUMBER
	4RKJ33491 <u>N9737922</u>	4RKJ3349X <u>P9738036</u>	
	4RKJ33493 <u>N9737923</u>	4RKJ33491 <u>P9738037</u>	1337 1363
	4RKJ33495 <u>N9737924</u>	4RKJ33493 <u>P9738038</u>	1340 1364
	4RKJ33497 <u>N9737925</u>	4RKJ33495 <u>P9738039</u>	1341 1365
	4RKJ33490 <u>N9737927</u>	4RKJ33491 <u>P9738040</u>	1342 1366
	4RKJ33492 <u>N9737928</u>	4RKJ33493 <u>P9738041</u>	1343 1367
	4RKJ33494 <u>N9737929</u>	4RKJ33495 <u>P9738042</u>	1345 1368
	4RKJ33496 <u>N9737964</u>	4RKJ33497 <u>P9738043</u>	1346 1369
	4RKJ33493 <u>N9737968</u>	4RKJ33499 <u>P9738044</u>	1347 1587
	4RKJ33491 <u>N9737970</u>	4RKJ33490 <u>P9738045</u>	1555 1588
	4RKJ33495 <u>P9738025</u>		1408 1589
		1410 1590	
		1526	

This bulletin does not necessarily apply to all the above-mentioned vehicles, some vehicles may have been modified before delivery.

### MATERIAL NEEDED

Writer: EL

<QF7720961 rev8>

Date	Expiration	Release	Page
03.2023	03.2025	1	2(19)

Order the following part:

Part No.	Description	Qty
7771979	DRIVER SEAT RECARO ERGO, ORANGE	1

### SAFETY PRECAUTIONS

- Eye protection should always be worn when working in a shop.
- Rules for Personal Protection Equipment should always be respected. Wear your PPE including but not limited to the following:



# Safety First!



---

Date	Expiration	Release	Page
03.2023	03.2025	1	3(19)

## Recaro Ergo Metro/Coach

### 3-POINT SEAT BELT INSTALLATION

TO ENSURE PROPER SEAT BELT FUNCTION, FOLLOW THE INSTALLATION INSTRUCTIONS BELOW

#### **Tools Needed:**

- Phillips #2 bit / screwdriver
- Small pick
- 5/8" hex wrench/socket
- 13 mm hex wrench/socket
- 6 mm Allen wrench
- Torque wrench
- Cordless drill

## PROCEDURE



### DANGER

Park vehicle safely, apply parking brake, stop the engine. Prior to working on the vehicle, set the ignition switch to the OFF position and trip the main circuit breakers equipped with a trip button. On Commuter type vehicles, set the battery master switch (master cut-out) to the OFF position.

Lockout & Tag out (LOTO) must be performed during set-up, maintenance or repair activities. Refer to your local procedure for detailed information regarding the control of hazardous energy.

## SEAT REMOVAL

1. In the front service compartment, disconnect the driver seat harness.



2. Under the driver seat, disconnect the air supply line.

Date	Expiration	Release	Page
03.2023	03.2025	1	5(19)

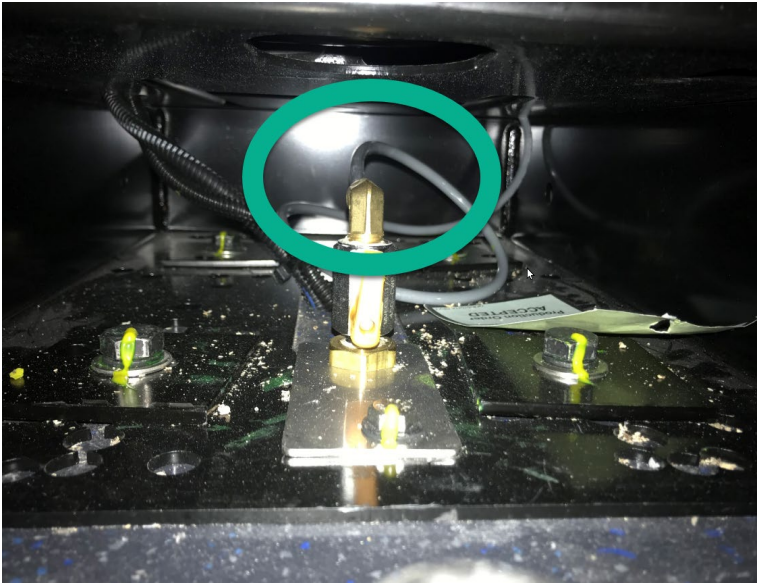

3. Unscrew and remove 6 screws attaching the seat to the riser (3 screws per side). Note if torque seal marks are present.

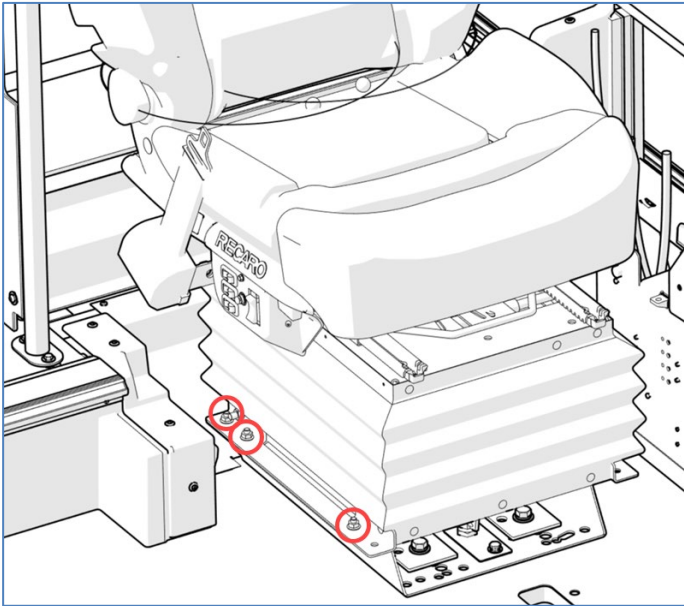

4. With the help of an assistant, pull the seat out of the bus.

Date	Expiration	Release	Page
03.2023	03.2025	1	6(19)

## BELT REMOVAL & INSTALLATION

1. Remove hole plugs from lower rear trim panel using small pick. Save for re-use. Remove rear lower trim panel using Phillips #2 screwdriver. Set aside caps, screws, and panel.



2. Remove 4 small caps with small pick from plastic back protector to allow access to 4 mounting screws. Remove 4 screws with Phillips #2 screwdriver. Set aside caps & screws. Remove plastic back protector.

Date	Expiration	Release	Page
03.2023	03.2025	1	7(19)



3. Using a Phillips screwdriver, remove the turning loop bracket trim cover from the turning loop bracket and discard cover and screws.

Date	Expiration	Release	Page
03.2023	03.2025	1	8(19)



4. Remove 5/8" nut cap. Disassemble the turning loop from the bracket with a 5/8" socket/ratchet and 5/8" wrench.

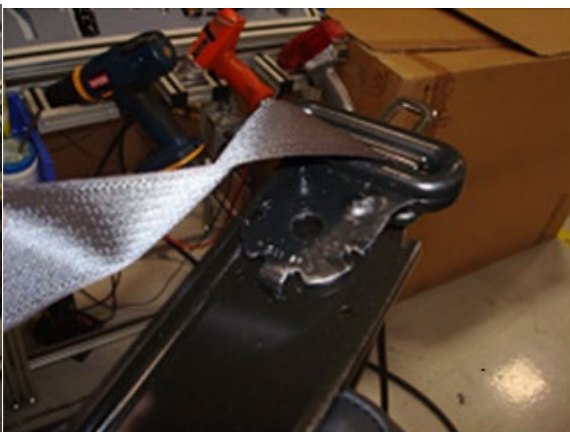

5. Remove retractor assembly from cushion frame with 13 mm hex wrench for the nuts, a 13 mm hex wrench for one bolt (shown), and a 6 mm Allen wrench for the other bolt.

Date	Expiration	Release	Page
03.2023	03.2025	1	9(19)



6. Lift back of cushion foam to remove from the Velcro pieces securing to the cushion frame. Flip cushion foam forward over thigh extension to access the side trim panel.
7. Remove left rear trim panel by removing the screw securing to the cushion frame with a Phillips #2 screwdriver. Slide panel upward along seat belt webbing to access the lap anchor bolt mounting location.



---

Date	Expiration	Release	Page
03.2023	03.2025	1	10(19)

8. Remove lap anchor bolt from the cushion frame using a 5/8" hex wrench. Set aside washers and bolt. If the seat also has a 2-point lap belt retractor, set aside.



9. Remove old seat belt assembly from the seat.

Date	Expiration	Release	Page
03.2023	03.2025	1	11(19)

10. Install new seat belt assembly 777979 at the retractor attachment first. Align the retractor with the 2 holes on the back of the cushion frame. Shown is a graphic for the correct arrangement of bolts and spacers used to install the retractor. Secure bolts to 22 Nm.

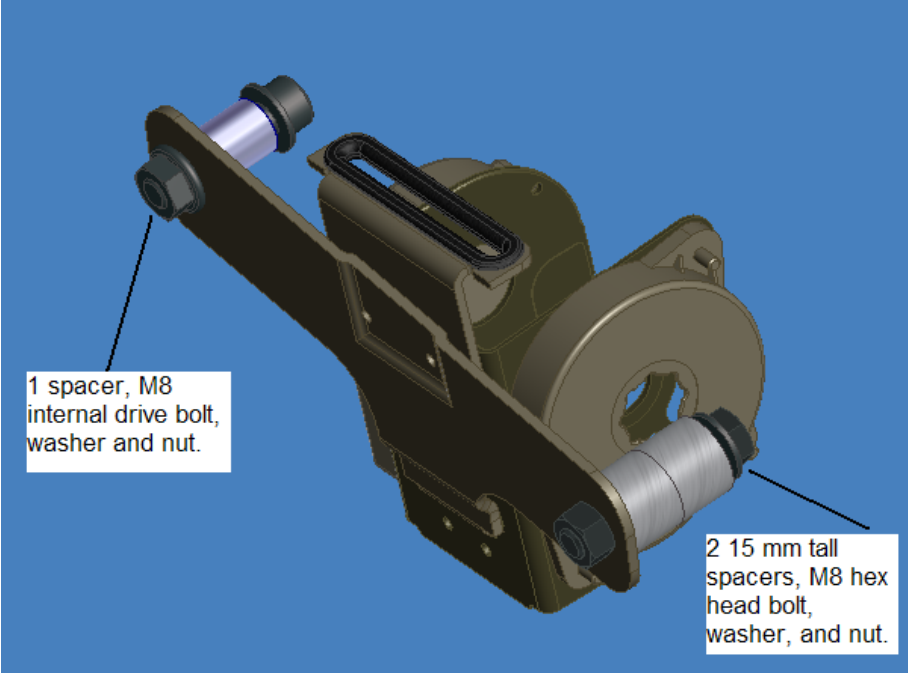

Date	Expiration	Release	Page
03.2023	03.2025	1	12(19)

11. After securing retractor, remove the plastic shipping clip from the webbing.

**NOTE: It is important to wait until the retractor is installed before removing the shipping clip. If removed prior to installation, too much webbing may feed into the retractor spool, preventing the retractor from working properly.**



12. Route turning loop up to the mounting location, ensuring that there are no twists in the webbing. Install turning loop to mounting bracket on the top of the seat back with 1 bolt, 2 washers and 1 locking nut, using a 5/8" wrench or socket. Torque to 50 Nm. Install new 5/8" cap over turning loop bolt.

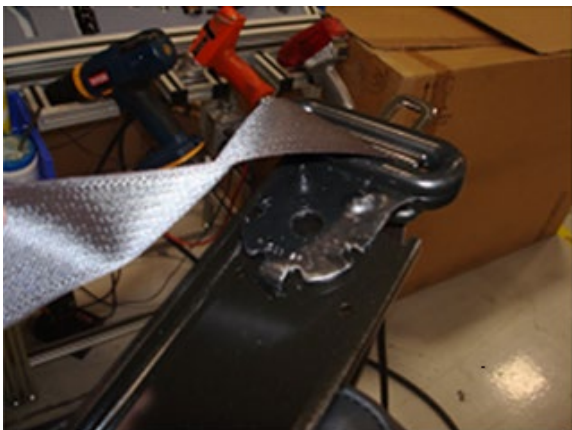

Date	Expiration	Release	Page
03.2023	03.2025	1	13(19)

13. Route the lap anchor through the opening in the left side trim panel, ensuring there are no twists in the webbing.
14. Place the 3/8" washer and 7/16" washer on the 7/16" bolt for the lap anchor, with the smaller washer closer to the head of the bolt.

Place the additional 7/16" washer on the other side of the anchor. Install the bolt into the attachment location on the seat. Torque to 50 Nm.

If the seat has a 2-point lap belt retractor, place the 3/8" and 7/16" washer on the bolt, then the retractor, and finally, the lap anchor. Install onto the seat and torque to 50 Nm.



---

Date	Expiration	Release	Page
03.2023	03.2025	1	14(19)

15. Slide the side trim panel down the webbing and align over the mounting location on the cushion frame. Secure the screw with a Phillips #2 screwdriver.



Date	Expiration	Release	Page
03.2023	03.2025	1	15(19)

16. Reinstall cover over turning loop using a Phillips #2 screwdriver.



17. Reinstall plastic back protector using a Phillips #2 screwdriver. Reinsert 4 hole plugs, using a small rubber mallet if necessary. Ensure that the top of the plastic back protector near the seat belt turning loop is routed through the loop of fabric sewn into the trim cover.

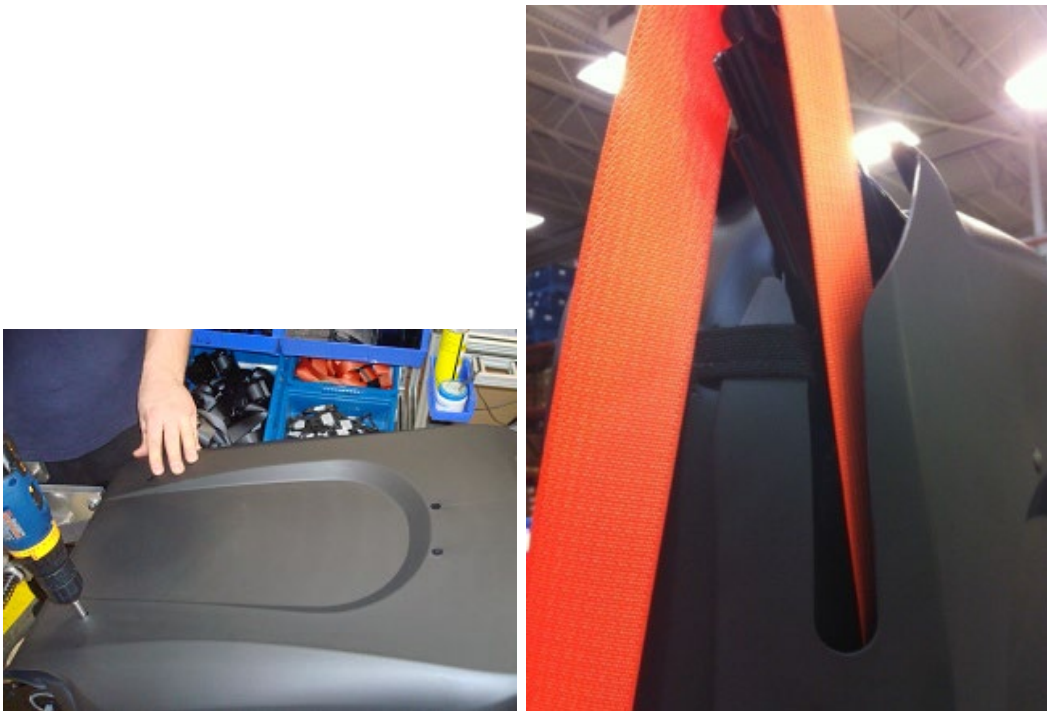

Date	Expiration	Release	Page
03.2023	03.2025	1	16(19)

18. Reinstall rear trim panel over the seat belt retractor on the back of the cushion frame with 2 screws using a Phillips #2 screwdriver. Install 2 pan head screws to the lower corners of the rear trim panel to the left and right-side trim panels. Insert hole plugs into the 2 holes in the rear trim panel.



*If any problems occur, please copy SEAT PART #, SEAT SERIAL # (Located on the top of the suspension near the back of the seat), before contacting RECARO Customer Service: 1-800-8RECARO*

## SEAT REINSTALLATION

1. Install the new seat with the 6 screws previously removed. For aesthetic consideration, apply torque seal marks only if torque seal marks were present on the previous installation.

***Torque to 16.5 lb-ft***

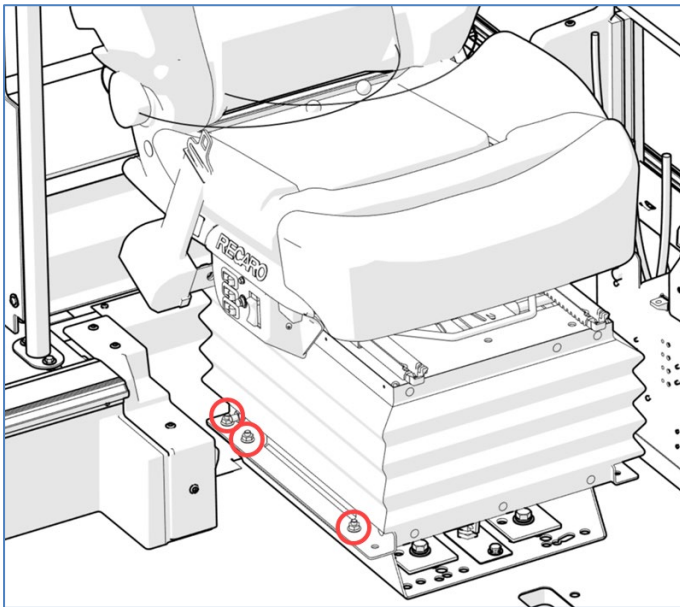

2. Under the seat, connect the seat air supply line from the push-in fitting.

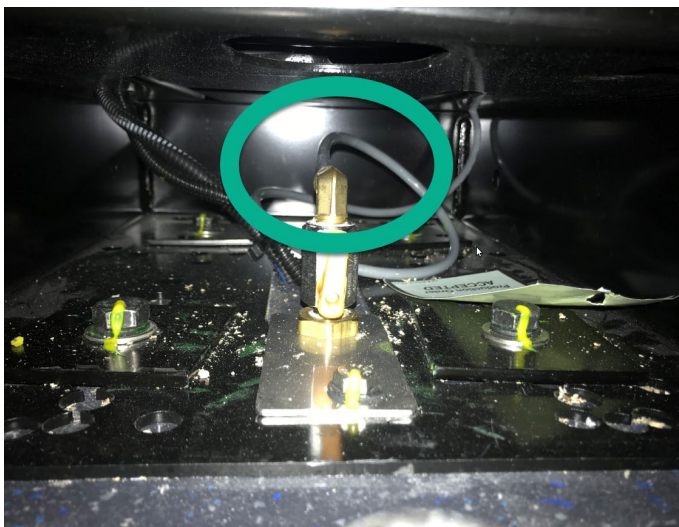

Date	Expiration	Release	Page
03.2023	03.2025	1	18(19)

3. In the front service compartment, connect the driver seat harness, red, black and Open.

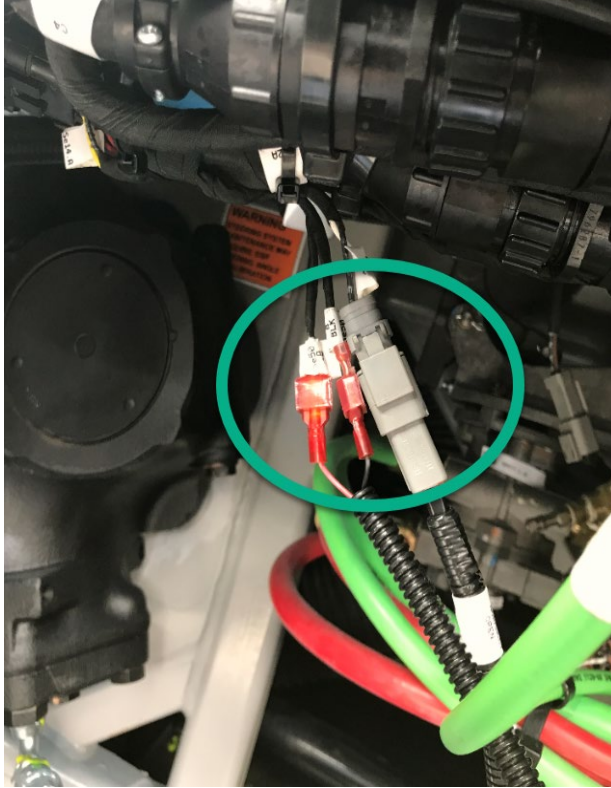

Date	Expiration	Release	Page
03.2023	03.2025	1	19(19)

## PARTS / WASTE DISPOSAL

Discard waste according to applicable environmental regulations (Municipal/State [Prov.]/ Federal)

## ESTIMATED TIME

The allowed time to perform the belt replacement is: 3 hours (3.0).

## OTHER

VBC Bulletin	N/A
Fail Code	18.03-3
Defect Code	09
Syst. Cond	B
Causal Part	860234

Access all our Service Bulletins on  
<http://techpub.prevostcar.com/en/>  
or scan the QR-Code with your smart phone.



Prevost engages in a continuous program of testing and evaluating to provide the best possible product. Prevost, however, is not committed to, or liable for updating existing products.