



# Service Action

## Code: 93P7

<b>Subject</b>	HV Battery Cell Module(s)															
<b>Release Date</b>	March 29, 2023															
<b>IMPORTANT!</b> <b>Battery Cell Evaluation/Replacement</b>	<ul style="list-style-type: none"><li><b>Vehicles with CRITERIA 02 in ELSA</b> have already been identified by the factory as requiring battery cell module replacement(s). Owners of these vehicles <b>MUST</b> schedule this service action directly with a certified Volkswagen battery repair dealer.</li><li><b>Vehicles with CRITERIA 04 in ELSA</b> can be scheduled for battery cell evaluation with any authorized Volkswagen dealer; however if the evaluation indicates battery cell replacement(s) is needed, the dealer performing the replacement(s) <b>MUST</b> be a certified Volkswagen battery repair dealer.</li></ul>															
<b>Affected Vehicles</b>	<table border="1"><thead><tr><th>Country</th><th>Beginning Model Year</th><th>Ending Model Year</th><th>Vehicle</th><th>Vehicle Count</th></tr></thead><tbody><tr><td>USA</td><td>2021</td><td>2022</td><td>ID4</td><td>20,949</td></tr><tr><td>CAN</td><td>2021</td><td>2022</td><td>ID4</td><td>1,431</td></tr></tbody></table> <p>Check Campaigns/Actions screen in ELSA on the day of repair to verify that a VIN qualifies for repair under this action. ELSA is the <u>only</u> valid campaign inquiry &amp; verification source.</p> <ul style="list-style-type: none"><li>✓ Campaign status must show "open."</li><li>✓ If ELSA shows other open action(s), inform your customer so that the work can also be completed at the same time the vehicle is in the workshop for this campaign.</li></ul>	Country	Beginning Model Year	Ending Model Year	Vehicle	Vehicle Count	USA	2021	2022	ID4	20,949	CAN	2021	2022	ID4	1,431
Country	Beginning Model Year	Ending Model Year	Vehicle	Vehicle Count												
USA	2021	2022	ID4	20,949												
CAN	2021	2022	ID4	1,431												
<b>Problem Description</b>	The high-voltage battery cells may experience an increased self-discharge due to a production fault. This can lead to a reduction in battery capacity and in driving range. If this condition exists in the vehicle, a warning lamp may illuminate and the message "Electronic system does not work correctly. Please go to workshop." may be shown in the infotainment display.															
<b>Corrective Action</b>	Evaluate and, if necessary, replace the affected battery cell module(s).															
<b>Code Visibility</b>	On or about March 29, 2023, the campaign code will be applied to affected vehicles.															
<b>Owner Notification</b>	Owner notification will take place in March 2023. Owner letter examples are included in this bulletin for your reference.															
<b>Campaign Expiration Date</b>	This campaign expires on <b>December 31, 2027</b> . Repairs must be performed on or before this date to be eligible for payment. Keep this expiration date in mind when scheduling customers for this action. If a customer wishes to have this service performed after the expiration date, your dealerships normal parts and labor cost associated with this repair will apply.															
<b>Additional Information</b>	<p><b>Please alert everyone in your dealership about this action, including Sales, Service, Parts and Accounting personnel. Contact Warranty if you have any questions.</b></p> <p>Dealers must ensure that every affected inventory vehicle has this campaign completed <u>before delivery to consumers.</u></p>															

The repair information in this document is intended for use only by skilled technicians who have the proper tools, equipment and training to correctly and safely maintain your vehicle. These procedures are not intended to be attempted by "do-it-yourselfers," and you should not assume this document applies to your vehicle, or that your vehicle has the condition described. To determine whether this information applies, contact an authorized Volkswagen dealer. ©2023 Volkswagen Group of America, Inc. and Volkswagen Canada. All Rights Reserved.

Fill out and affix Campaign Completion Label (CAMP 010 000) after work is complete.  
*Labels can be ordered at no cost via the Compliance Label Ordering portal at [www.vwhub.com](http://www.vwhub.com).*

## Parts Information (if required)

**Parts Control Type:**  
**Free Order** Parts will be managed by Free Order

**Initial Allocation:**  
**NO** There will be no parts allocation. Please reference the Repair Projection Tool (below) to view your potential VIN population.

**Repair Projection Tool:**  
**(right click to open)** 

Criteria	Quantity	Part Number	P.O.C. Part Description	Ordering Method
ALL	As needed	0Z1-915-599-H	CELL MOD.	Free Order
	<b>IMPORTANT INFORMATION FOR PART NUMBER 0Z1-915-599-H (Cell module):</b> 0Z1-915-599-H (Cell Module) will be return blocked. In the chance that a cell module needs returning, this return will need to be schedule with your Dealer Support Specialist (DSS).  For batteries not actively part of the repair process, either new or spent, dealers should ensure compliance with local fire code battery storage requirements. Dealers who have the appropriate storage capabilities/facilities that meet local fire code requirements, are encouraged to order/ stock parts to complete the 93P7 Repair.			
	4 per cell module	N -912-809-01	SCREW	
	1 per cell module	D -G00-018-M3	PASTE	
	1 per cell module	0Z1-998-474	SEP. FILM	
	1	D -316-000-A1	UNDER COAT	
	1	D -454-300-H2	SEALANT	
	1	11A-998-844-A	Parts Kit* (see next page for kit contents)	
	As needed	G -12E-100-1G CON or G -12E-100-1L DSP or G -12E-100-2L DSP	G12 EVO Coolant Concentrate	
	The following underbody trim clips are needed ONLY in the event of breakage. They may not be required for every repair.			
Up to 14	WHT-003-491	NUT		

### NOTE

The specified part numbers reflect the status at the start of this action. Interim updates made in ETKA can cause a listed part number to become unavailable. In this case, the new part number specified in ETKA should be used.

**\*11A-998-844-A PARTS KIT CONTENTS**

<b>Quantity</b>	<b>Part Number</b>	<b>Part Description</b>
1	1HV-915-754-A	VALVE
2	0Z1-915-433-C	GASKET
24	N -909-428-04	BOLT
4	N -912-832-01	BOLT
82	WHT-009-218	BOLT
22	WHT-008-738-A	BOLT
1	1EA-802-131-A	CONNECTION
1	1EA-802-132-A	CONNECTION
1	1EA-998-103	SEP. FILM
4	N -102-252-02	BOLT

The repair information in this document is intended for use only by skilled technicians who have the proper tools, equipment and training to correctly and safely maintain your vehicle. These procedures are not intended to be attempted by "do-it-yourselfers," and you should not assume this document applies to your vehicle, or that your vehicle has the condition described. To determine whether this information applies, contact an authorized Volkswagen dealer. ©2023 Volkswagen Group of America, Inc. and Volkswagen Canada. All Rights Reserved.

## Claim Entry Instructions

The labor times listed here may differ from the labor operations and labor times listed in ELSA.

After campaign has been completed, enter claim as soon as possible to help prevent work from being duplicated elsewhere. Attach the ELSA screen print showing action open on the day of repair to the repair order.

If customer refused campaign work:

- ✓ U.S. dealers: Submit request via WISE under the *Campaigns/Update/Recall Closure* option.
- ✓ Canada dealers: Upload the repair order [signed by customer] to Volkswagen WIN/Operations/Campaign Closure.

<b>Service Number</b>	93P7
<b>Damage Code</b>	0099
<b>Parts Vendor Code</b>	WWO
<b>Claim Type</b>	Sold vehicle: 7 10 Unsold vehicle: 7 90
<b>Causal Indicator</b>	Mark labor as causal if cell module(s) are not replaced Mark CELL MOD* as causal part if a cell module(s) is replaced
<b>Vehicle Wash</b>	Do not claim wash under this action
<b>Vehicle Loaner (USA ONLY)</b>	See special claiming instructions for rental/loaner claiming. <b>NOTE: A second claim must be entered for rental/loaner claiming</b>
<b>Vehicle Loaner (Canada ONLY)</b>	Loaner/rental coverage cannot be claimed under this action. Please refer to the Volkswagen Service Loaner Program to determine loaner eligibility.
<b>IMPORTANT CLAIMING INFORMATION</b>	The claiming operations are separated between non-battery repair dealers and battery repair dealers. Use the correct claiming section based on your dealer's battery repair certification status.  If a vehicle is inspected at a NON-battery repair dealer and a cell module requires replacement, the dealer inspecting the vehicle can claim the GFF time for performing the test plan only.  The cell module replacement will then be completed by a certified battery repair dealer.

Continued on next page

## NON-BATTERY REPAIR DEALER CLAIMING

<b>Criteria Details</b>	<p><b>Criteria 02</b> = Vehicle has pre-identified cell module(s) to replace. <i>Non-battery repair dealers cannot perform the inspection or the repair. Non-battery repair dealers will not be reimbursed for work on any Criteria 02 vehicle.</i></p> <p><b>Criteria 04</b> = No pre-identified cell module(s). Vehicle requires GFF test plan to check for cell modules with increased self-discharge.</p> <p>Criteria 04 vehicles also have criteria C1 and C2 assigned to them.</p> <p style="padding-left: 40px;">C1: Test plan results = HV battery is OK and NO cell modules require replacement.</p> <p style="padding-left: 40px;">C2: Test plan results = one or more cell modules require replacement.</p>		
<b>Criteria ID: C1, C2 and 04</b> <b><u>Scenario 1</u></b>	<p>Vehicle did not have pre-identified cell module(s) to replace.</p> <p>GFF test plan indicated that no cell modules have increased self-discharge.</p> <p>No cell module(s) required replacement.</p> <p><b>Enter ONLY Criteria C1</b></p>		
	<b>LABOR</b>		
	<b>Labor Op</b>	<b>Time Units</b>	<b>Description</b>
	0183 00 99	10 TU + Time stated on diagnostic protocol	Connect battery charger and perform "check cell equalization" test plan
<b>Criteria ID: C1, C2 and 04</b> <b><u>Scenario 2</u></b>	<p>Vehicle did not have pre-identified cell module(s) to replace.</p> <p>GFF test plan indicated cell module(s) have increased self-discharge.</p> <p>Cell module(s) require replacement.</p> <p>Cell module replacement cannot be performed at your dealer.</p> <p><b>Enter ONLY criteria C2</b></p>		
<b>IMPORTANT</b>	<p style="color: red;"><b><u>DO NOT CLAIM CRITERIA C1 or 04!</u></b></p> <p><b>Enter ONLY criteria C2.</b> Doing so will allow the dealer inspecting the vehicle to claim the inspection time without closing the campaign in ELSA. This also allows the dealer repairing the vehicle to claim the cell module replacement.</p>		
	<b>LABOR</b>		
	<b>Labor Op</b>	<b>Time Units</b>	<b>Description</b>
	9301 01 99	10 TU + Time stated on diagnostic protocol	Connect battery charger and perform "check cell equalization" test plan
<b>Criteria ID: C1 and 04</b>	<p>Check service history for a previous 93P7 inspection claim.</p> <p>If a 93P7 inspection was previously performed, no work can be performed by a non-battery repair dealer.</p>		

**-END NON-BATTERY REPAIR DEALER CLAIMING-**

## BATTERY REPAIR DEALER CLAIMING

<b>Criteria Details</b>	<p><b>Criteria 02</b> = Vehicle has pre-identified cell module(s) to replace.</p> <p><b>Criteria 04</b> = No pre-identified cell module(s). Vehicle requires GFF test plan to check for cell modules with increased self-discharge.</p> <p>Criteria 04 vehicles also have criteria C1 and C2 assigned to them.</p> <p style="padding-left: 40px;">C1: Test plan results = HV battery is OK and NO cell modules require replacement.</p> <p style="padding-left: 40px;">C2: Test plan results = one or more cell modules require replacement.</p>						
<b>Criteria ID: C1, C2 and 04</b> <b>Scenario 1</b>	<p>Vehicle did not have pre-identified cell module(s) to replace</p> <p>GFF test plan indicated that no cell modules have increased self-discharge</p> <p>No cell module(s) required replacement</p> <p><b>Enter ONLY Criteria C1</b></p>						
	<b>LABOR</b>						
	<table border="1" style="width: 100%; border-collapse: collapse;"> <thead> <tr> <th style="width: 25%;">Labor Op</th> <th style="width: 25%;">Time Units</th> <th style="width: 50%;">Description</th> </tr> </thead> <tbody> <tr> <td style="text-align: center;">0183 00 99</td> <td style="text-align: center;">10 TU + Time stated on diagnostic protocol</td> <td>Connect battery charger and perform "check cell equalization" test plan</td> </tr> </tbody> </table>	Labor Op	Time Units	Description	0183 00 99	10 TU + Time stated on diagnostic protocol	Connect battery charger and perform "check cell equalization" test plan
Labor Op	Time Units	Description					
0183 00 99	10 TU + Time stated on diagnostic protocol	Connect battery charger and perform "check cell equalization" test plan					

<b>Criteria ID: C1, C2 and 04</b> <b>Scenario 2</b>	<p>No pre-identified cell modules, but GFF test plan indicates cell module(s) require replacement:</p> <p><b>Enter ONLY Criteria 04</b></p>															
<b>OR</b>																
<b>Criteria ID: 02</b>	<p>Vehicle has pre-identified cell module(s) requiring replacement:</p> <p><b>Enter ONLY Criteria 02</b></p>															
<b>OR</b>																
<b>Criteria ID: C1 and 04</b>	<p>The 93P7 inspection was previously performed.</p> <p>Cell module(s) require replacement.</p> <p><b>Enter ONLY Criteria 04</b></p>															
	<b>LABOR</b>															
	<table border="1" style="width: 100%; border-collapse: collapse;"> <thead> <tr> <th style="width: 25%;">Labor Op</th> <th style="width: 25%;">Time Units</th> <th style="width: 50%;">Description</th> </tr> </thead> <tbody> <tr> <td style="text-align: center;">9301 55 99</td> <td style="text-align: center;">635</td> <td>Replace single (or first) cell module</td> </tr> <tr> <td style="text-align: center;">9305 01 99</td> <td style="text-align: center;">10</td> <td>Check and measure HV battery cover (if necessary)</td> </tr> <tr> <td style="text-align: center;">9329 01 99</td> <td style="text-align: center;">120</td> <td>Clean HV battery cover (if HV battery cover is reused)</td> </tr> <tr> <td style="text-align: center;">2706 89 50</td> <td style="text-align: center;">10</td> <td>Connect battery charger (if necessary)</td> </tr> </tbody> </table>	Labor Op	Time Units	Description	9301 55 99	635	Replace single (or first) cell module	9305 01 99	10	Check and measure HV battery cover (if necessary)	9329 01 99	120	Clean HV battery cover (if HV battery cover is reused)	2706 89 50	10	Connect battery charger (if necessary)
Labor Op	Time Units	Description														
9301 55 99	635	Replace single (or first) cell module														
9305 01 99	10	Check and measure HV battery cover (if necessary)														
9329 01 99	120	Clean HV battery cover (if HV battery cover is reused)														
2706 89 50	10	Connect battery charger (if necessary)														

**Continued on next page**

<b>LABOR</b>		
<b>Labor Op</b>	<b>Time Units</b>	<b>Description</b>
0150 00 00	Time stated on diagnostic protocol	All GFF Operations
<p><i>NOTE: If GFF work is performed on more than one diagnostic session, the multiple GFF logs can be added together.</i></p> <p><i>Claims will stop for review if the max allowed GFF time is exceeded. Ensure the GFF logs are added together correctly. For example, two logs from the same diagnostic session are not allowed.</i></p> <p><i>All GFF operations will be claimed under ONE labor operation. The time it takes to complete all GFF work will be accounted for under labor operation 0150 00 00. DO NOT enter labor operation 0150 00 00 more than once.</i></p>		
<b>PARTS</b>		
<b>Quantity</b>	<b>Part Number</b>	<b>Description</b>
1.00	0Z1915599H	CELL MOD*
4.00	N 91280901	SCREW
1.00	D G00018M3	PASTE
1.00	0Z1998474	SEP. FILM
1.00	D 316000A1	UNDER COAT
1.00	D 454300H2	SEALANT
1.00	11A998844A	Parts Kit
Up to 20.00	G 12E100S0 or G 12E100S1	COOLANT CONCENTRATE

**Continued on next page**



	<p>Add the following for additional cell modules being replaced.</p> <p><b>EXAMPLE 1:</b> A vehicle with pre-identified cell module(s) requiring replacement also requires 2 <u>additional</u> cell modules replaced as directed by the test plan:</p> <ul style="list-style-type: none"> <li>You will combine the total quantity of parts replaced (i.e. 3.00 cell modules, 12.00 screws, etc.)</li> <li>For the two <u>additional</u> cell modules, you will claim a single labor operation of 200 TU under LO 9301 19 99</li> </ul> <p><b>EXAMPLE 2:</b> A vehicle has three pre-identified cell modules and no other cell modules require replacement according to the GFF test plan:</p> <ul style="list-style-type: none"> <li>You will combine the total quantity of parts replaced (i.e. 3.00 cell modules, 12.00 screws, etc.)</li> <li>For the two <u>additional</u> cell modules, you will claim a single labor operation of 200 TU under LO 9301 19 99</li> </ul>
--	---

<b>LABOR</b>		
<b>Labor Op</b>	<b>Time Units</b>	<b>Description</b>
9301 19 99	100 <i>(per additional cell module)</i>	Battery module remove+reinstall <i>(total TU is the # of modules replaced x 100)</i>
<b>PARTS</b>		
<b>Quantity</b>	<b>Part Number</b>	<b>Description</b>
1.00/cell module	0Z1915599H	CELL MOD.
4.00/cell module	N 91280901	SCREW
1.00/cell module	D G00018M3	PASTE
1.00/cell module	0Z1998474	SEP. FILM

	The following can be added if the HV battery cover required replacement		
<b>PARTS</b>			
<b>Quantity</b>	<b>Part Number</b>	<b>Description</b>	
1.00	1EA804841AC	HOUSING	
8.00	1EA804973	HOLDER	
1.00	1EA010505	WARN. SIGN	
1.00	12E010006AA	STICKER	

	The following can be added as needed in the event of breakage during the repair.		
<b>PARTS</b>			
<b>Quantity</b>	<b>Part Number</b>	<b>Description</b>	
As required	WHT003491	NUT	
As required	WHT009733	BOLT	
As required	8E0825267	PUSH PIN	
As required	N 0385494	RIVET	

**Continued on next page**

<b>Vehicle Loaner (USA ONLY)</b>	<b>Enter vehicle loaner claim as a separate, second claim</b> <b>Allowed time = up to 3 days</b> <b>Loaner coverage can only be claimed if a cell module requires replacement</b>		
	<b>Claim Type</b>	1 SP	
	<b>Service Number</b>	X182	
	<b>Damage Code</b>	0055	
	<b>Damage Location</b>	Blank	
	<b>Parts Vendor Code</b>	K21	
	<b>Outside Labor Operation</b>	X182US01 (mark as causal)	Enter dollar amount on rental/loaner invoice (Up to \$53 per day)

## Customer Letter Example (USA) – (Vehicles Needing Inspection/Any Dealer) – CR04

This notice applies to your vehicle: <MODEL YEAR> <BRAND> <CARLINE>, <VIN>

**Subject: Service Action 93P7 - HV Battery Cell Module(s)**

Dear Volkswagen Owner,

As part of Volkswagen's ongoing commitment to customer satisfaction, we are informing you of our decision to conduct a service action on certain 2021-2022 model year Volkswagen ID.4 vehicles. Our records show that you are the owner of a vehicle affected by this action.

**What is the issue?** The high-voltage battery cells may experience an increased self-discharge due to a production fault. This can lead to a reduction in battery capacity and in driving range. If this condition exists in the vehicle, a warning lamp may illuminate and the message "*Electronic system does not work correctly. Please go to workshop.*" may be shown in the infotainment display.

**What will we do?** To identify this issue, your authorized Volkswagen dealer will evaluate your vehicle to determine if any battery cell module(s) needs replacement. The evaluation will take less than an hour to complete, and will be free of charge.

If the evaluation shows a battery cell module(s) needs replacement, your Volkswagen dealer may be able to perform the work if they are a certified Volkswagen battery repair dealer. If they are not, you will need to make an appointment to have this work completed at a certified Volkswagen battery repair dealer. The work to do the replacement will take at least one day to complete and will be performed for you free of charge.

Your dealer may need additional time for the preparation of the repair, as well as to accommodate their daily workshop schedule.

**Important information to keep in mind when scheduling this service action:** All authorized Volkswagen dealers can perform the battery cell evaluation under this action; however, if your vehicle needs to have battery cell module(s) replaced, replacement can only be performed by a certified Volkswagen battery repair dealer.

When making your appointment for this service action, you will want to check with your Volkswagen dealer to see if they are a certified Volkswagen battery repair dealer. If you elect to have a dealer that is not a certified battery repair dealer perform the evaluation described in this letter, you will be responsible for taking your vehicle to a certified battery repair dealer in the event any cell module needs replacement.

**What should you do?** Please contact your authorized Volkswagen dealer as soon as possible to schedule this service. To set up an appointment online, please visit [www.vw.com/find-a-dealer](http://www.vw.com/find-a-dealer).

This service action will be available for you free of charge only until December 31, 2027. If you wish to have this service performed after that date, your dealer's normal costs associated with this repair will apply.

**Lease vehicles and address changes** If you are the lessor and registered owner of the vehicle identified in this action, please forward this letter immediately via first-class mail to the lessee within ten (10) days of receipt. If you have changed your address or sold the vehicle, please fill out the enclosed prepaid Owner Reply card and mail it to us so we can update our records.

**Can we assist you further?** If your authorized Volkswagen dealer fails or is unable to complete this work free of charge within a reasonable time, or if you should have any questions about this communication, please reach out to us using your preferred method of communication at [www.vw.com/contact](http://www.vw.com/contact) or by calling us at 800-893-5298.

**Checking your vehicle for open Recalls and Service Campaigns** To check your vehicle's eligibility for repair under this or any other recall/service campaign, please visit [www.vw.com/owners/recalls](http://www.vw.com/owners/recalls) and enter your Vehicle Identification Number (VIN) into the Recall/Service Campaign Lookup tool.

We apologize for any inconvenience this matter may cause; however we are taking this action to help ensure your safety and continued satisfaction with your vehicle.

Sincerely,

Volkswagen Customer Protection

(CR04)

## Customer Letter Example (USA) – (Vehicles Need Cell Replace / Battery Rep. Dealer) – CR02

This notice applies to your vehicle: <MODEL YEAR> <BRAND> <CARLINE>, <VIN>

**Subject: Service Action 93P7 - HV Battery Cell Module(s)**

Dear Volkswagen Owner,

As part of Volkswagen's ongoing commitment to customer satisfaction, we are informing you of our decision to conduct a service action on certain 2021-2022 model year Volkswagen ID.4 vehicles. Our records show that you are the owner of a vehicle affected by this action.

- What is the issue?** The high-voltage battery cells may experience an increased self-discharge due to a production fault. This can lead to a reduction in battery capacity and in driving range. If this condition exists in the vehicle, a warning lamp may illuminate and the message “*Electronic system does not work correctly. Please go to workshop.*” may be shown in the infotainment display.
- What will we do?** To identify and correct this issue, your certified Volkswagen battery repair dealer will evaluate and replace the affected battery cell module(s) as needed. This work will take at least one day to complete and will be performed for you free of charge. Please keep in mind that your dealer may need additional time for the preparation of the repair, as well as to accommodate their daily workshop schedule.
- What should you do?** Please contact your certified Volkswagen battery repair dealer as soon as possible to schedule this service. To set up an appointment online, please visit [www.vw.com/find-a-dealer](http://www.vw.com/find-a-dealer).
- This service action will be available for you **free of charge only until December 31, 2027**. If you wish to have this service performed after that date, your dealer's normal costs associated with this repair will apply.
- Schedule with a certified Volkswagen battery repair dealer** According to our records, your vehicle will need certain battery cell module(s) replaced under this action. Please keep in mind that only a certified Volkswagen battery repair dealer can perform repairs under this service action. When making your appointment for this service action, please ensure your dealer is a certified Volkswagen battery repair dealer.
- Lease vehicles and address changes** If you are the lessor and registered owner of the vehicle identified in this action, please forward this letter immediately via first-class mail to the lessee within ten (10) days of receipt. If you have changed your address or sold the vehicle, please fill out the enclosed prepaid Owner Reply card and mail it to us so we can update our records.
- Can we assist you further?** If your certified Volkswagen battery repair dealer fails or is unable to complete this work free of charge within a reasonable time, or if you should have any questions about this communication, please reach out to us using your preferred method of communication at [www.vw.com/contact](http://www.vw.com/contact) or by calling us at 800-893-5298.
- Checking your vehicle for open Recalls and Service Campaigns** To check your vehicle's eligibility for repair under this or any other recall/service campaign, please visit [www.vw.com/owners/recalls](http://www.vw.com/owners/recalls) and enter your Vehicle Identification Number (VIN) into the Recall/Service Campaign Lookup tool.

We apologize for any inconvenience this matter may cause; however we are taking this action to help ensure your safety and continued satisfaction with your vehicle.

Sincerely,

Volkswagen Customer Protection

(CR02)

## Customer Letter Example (Canada) - (Vehicles Needing Inspection/Any Dealer) CR04

This notice applies to your vehicle: <MODEL YEAR> <BRAND> <CARLINE>, <VIN>

**Subject: Service Action 93P7 - HV Battery Cell Module(s)**

Dear Volkswagen Owner,

As part of Volkswagen's ongoing commitment to customer satisfaction, we are informing you of our decision to conduct a service action on certain 2021-2022 model year Volkswagen ID.4 vehicles. Our records show that you are the owner of a vehicle affected by this action.

**What is the issue?** The high-voltage battery cells may experience an increased self-discharge due to a production fault. This can lead to a reduction in battery capacity and in driving range. If this condition exists in the vehicle, a warning lamp may illuminate and the message "*Electronic system does not work correctly. Please go to workshop.*" may be shown in the infotainment display.

**What will we do?** To identify this issue, your authorized Volkswagen dealer will evaluate your vehicle to determine if any battery cell module(s) needs replacement. The inspection will take less than an hour to complete, and will be free of charge.

If the evaluation shows a battery cell module(s) needs replacement, your Volkswagen dealer may be able to perform the work if they are a certified Volkswagen battery repair dealer. If they are not, you will need to make an appointment to have this work completed at a certified Volkswagen battery repair dealer. The work to do the replacement can take at least one day to complete and will be performed for you free of charge.

Your dealer may need additional time for the preparation of the repair, as well as to accommodate their daily workshop schedule.

**Important information to keep in mind when scheduling this service action:** All authorized Volkswagen dealers can perform the battery cell evaluation under this action; however, if your vehicle needs to have battery cell module(s) replaced, replacement can only be performed by a certified Volkswagen battery repair dealer.

When making your appointment for this service action, you will want to check with your Volkswagen dealer to see if they are a certified Volkswagen battery repair dealer. If you elect to have a dealer that is not a certified battery repair dealer perform the evaluation described in this letter, you will be responsible for taking your vehicle to a certified battery repair dealer in the event any cell module needs replacement.

**What should you do?** Please contact your authorized Volkswagen dealer as soon as possible to schedule this service.

This service action will be available for you **free of charge only until December 31, 2027**. If you wish to have this service performed after that date, your dealer's normal costs associated with this repair will apply.

**Lease vehicles and address changes** If you are the lessor and registered owner of the vehicle identified in this letter, you shall forward this letter (and any subsequent notice, if applicable) to the lessee within ten (10) days of receipt. If you have changed your address or sold the vehicle identified in this letter, please fill out the enclosed prepaid Owner Reply Card and mail it to us so we can update our records.

**Can we assist you further?** If your authorized Volkswagen dealer fails or is unable to complete this work free of charge within a reasonable time, please contact Customer Relations, Monday through Friday from 8AM to 8PM EST by phone at 1-800-822-8987 or via our "Contact Us" page at [www.vw.ca](http://www.vw.ca).

We apologize for any inconvenience this matter may cause; however we are taking this action to help ensure your safety and continued satisfaction with your vehicle.

Sincerely,

Volkswagen Customer Protection

(CR04)

The repair information in this document is intended for use only by skilled technicians who have the proper tools, equipment and training to correctly and safely maintain your vehicle. These procedures are not intended to be attempted by "do-it-yourselfers," and you should not assume this document applies to your vehicle, or that your vehicle has the condition described. To determine whether this information applies, contact an authorized Volkswagen dealer. ©2023 Volkswagen Group of America, Inc. and Volkswagen Canada. All Rights Reserved.

## Customer Letter Example (Canada) – (Vehicles Need Cell Replace / Battery Rep. Dealer) CR02

<MONTH YEAR>

<CUSTOMER NAME>

<CUSTOMER ADDRESS>

<CUSTOMER CITY STATE ZIPCODE>

**This notice applies to your vehicle:** <MODEL YEAR> <BRAND> <CARLINE>, <VIN>

**Subject: Service Action 93P7 - HV Battery Cell Module(s)**

Dear Volkswagen Owner,

As part of Volkswagen's ongoing commitment to customer satisfaction, we are informing you of our decision to conduct a service action on certain 2021-2022 model year Volkswagen ID.4 vehicles. Our records show that you are the owner of a vehicle affected by this action.

**What is the issue?** The high-voltage battery cells may experience an increased self-discharge due to a production fault. This can lead to a reduction in battery capacity and in driving range. If this condition exists in the vehicle, a warning lamp may illuminate and the message *"Electronic system does not work correctly. Please go to workshop."* may be shown in the infotainment display.

**What will we do?** To identify and correct this issue, your certified Volkswagen battery repair dealer will evaluate and replace the affected battery cell module(s) as needed. This work will take at least one day to complete and will be performed for you free of charge. Please keep in mind that your dealer may need additional time for the preparation of the repair, as well as to accommodate their daily workshop schedule.

**What should you do?** Please contact your certified Volkswagen battery dealer as soon as possible to schedule this service.

This service action will be available for you **free of charge only until December 31, 2027**. If you wish to have this service performed after that date, your dealer's normal costs associated with this repair will apply.

**Schedule with a certified Volkswagen battery repair dealer** According to our records, your vehicle will need certain battery cell module(s) replaced under this action. Please keep in mind that only a certified Volkswagen battery repair dealer can perform repairs under this service action. When making your appointment for this service action, please ensure your dealer is a certified Volkswagen battery repair dealer.

**Lease vehicles and address changes** If you are the lessor and registered owner of the vehicle identified in this letter, you shall forward this letter (and any subsequent notice, if applicable) to the lessee within ten (10) days of receipt. If you have changed your address or sold the vehicle identified in this letter, please fill out the enclosed prepaid Owner Reply Card and mail it to us so we can update our records.

**Can we assist you further?** If your certified Volkswagen battery repair dealer fails or is unable to complete this work free of charge within a reasonable time, please contact Customer Relations, Monday through Friday from 8AM to 8PM EST by phone at 1-800-822-8987 or via our "Contact Us" page at [www.vw.ca](http://www.vw.ca).

We apologize for any inconvenience this matter may cause; however we are taking this action to help ensure your safety and continued satisfaction with your vehicle.

Sincerely,

Volkswagen Customer Protection

(CR02)

The repair information in this document is intended for use only by skilled technicians who have the proper tools, equipment and training to correctly and safely maintain your vehicle. These procedures are not intended to be attempted by "do-it-yourselfers," and you should not assume this document applies to your vehicle, or that your vehicle has the condition described. To determine whether this information applies, contact an authorized Volkswagen dealer. ©2023 Volkswagen Group of America, Inc. and Volkswagen Canada. All Rights Reserved.

## Safety Precautions When Working ON the High-voltage System (additional information is also available in the ELSA Repair Manual)

### DANGER

#### **Extremely dangerous due to high voltage.**

- The high-voltage system is under heavy voltage. Severe bodily injury or death by electrocution or electric arcs is possible.
- When working on the high-voltage system the high-voltage system must be de-energized.
- When performing procedures that do not directly affect the high-voltage system, in some cases it is still necessary to de-energize the high-voltage system.
- Pay attention when the high-voltage system must be de-energized. Refer to the Repair Manual
- Have a High-Voltage Technician or a High-Voltage Expert de-energize the high-voltage system.

#### **The electric and magnetic fields are extremely dangerous.**

- There are electric and magnetic fields on the high-voltage system. Death or serious injury are possible due to malfunction of active implants (for example cardiac pacemakers, insulin pumps).
- Persons with active implants may not perform procedures on the high-voltage system.

### WARNING

#### **Risk of injury - motor may start unexpectedly**

It is difficult to determine whether the drive system of an electric vehicle or hybrid vehicle is active. Moving parts can trap or draw in parts of the body.

### CAUTION

#### **Risk of damage to high-voltage wiring**

- Incorrect handling may result in damage to the insulation of high-voltage wires or high-voltage connectors.
- Do not support yourself on high-voltage cables or connectors.
- Never prop tools against high-voltage wiring or high-voltage connectors.
- Never bend or kink high-voltage wiring.
- Observe the coding of the high-voltage connectors when joining them up.

## Safety Precautions When Working NEAR the High-voltage System (additional information is also available in the ELSA Repair Manual)

### DANGER

#### **Extremely dangerous due to high voltage.**

- The voltage levels in the high-voltage system constitute a safety hazard. Danger of severe or fatal injuries from electric shock if high-voltage components or high-voltage wiring are damaged.
- Carry out a visual check of high-voltage components and high-voltage wiring.
- Never use cutting/forming tools or other sharp-edged implements.
- Never perform work using welding, brazing, thermal bonding or hot air in the area of high-voltage components and high-voltage cables.

 **DANGER**

**High voltage increases the risk of fatal injury**

**Electrocution can cause severe bodily or fatal injury.**

- For the following procedures suitable personal protective equipment must be worn.
- For the following steps two correspondingly qualified technicians must be present for the supervision.
- If necessary, a second technician can help the high-voltage expert outside of the hazardous area within their qualification.
- The personal protective equipment (PPE) must be dry and undamaged.



## Repair Overview

### NON-BATTERY REPAIR DEALERS

#### Criteria 02 vehicles:

- Cell modules require replacement.
- Work cannot be performed by a non-battery repair dealer.

#### Criteria C1, C2 and 04 vehicles:

- Perform a test plan to check for cell modules with an increased self-discharge.
- If the vehicle requires a cell module replacement, the replacement must be completed at a battery repair dealer.

#### Criteria C1 and 04 vehicles:

- Check service history for a previous 93P7 inspection claim.
- If a 93P7 inspection was previously performed, cell modules require replacement.
- Work cannot be performed by a non-battery repair dealer.

### CERTIFIED BATTERY REPAIR DEALERS

#### Criteria 02 vehicles:

- Perform a test plan to check for cell modules with an increased self-discharge and replace as needed.
- Replace pre-identified cell module(s) inside the high voltage battery.

#### Criteria C1, C2 and 04 vehicles:

- Perform a test plan to check for cell modules with an increased self-discharge and replace if needed.

#### Criteria C1 and 04 vehicles:

- The 93P7 inspection was previously performed. Cell modules require replacement.
- Perform a test plan to check which cell modules with an increased self-discharge require replacement.

### CRITICAL REPAIR STEP









 **STOP!** 

NON-Battery Repair dealers CANNOT perform ANY work on vehicles assigned Criteria 02. These vehicles are known to need a cell module replacement and MUST be checked and repaired at a battery repair dealer. NON-Battery Repair dealers will not be reimbursed for any work performed on Criteria 02 vehicles.

 **NOTE**

- These repair instructions may differ from the labor operations and labor times listed in ELSA.
- Damages resulting from improper repair or failure to follow these work instructions are the dealer's responsibility and are not eligible for reimbursement under this action.
- This procedure must be read in its entirety prior to performing the repair.
- Due to variations in vehicle equipment and options, the steps/illustrations in this work procedure may not identically match all affected vehicles.
- Diagnosis and repair of pre-existing conditions in the vehicle are not covered under this action.
- When working during extreme temperatures, it is recommended that the vehicle be allowed to acclimate inside the shop to avoid temperature-related component damage/breakage.

## Required Tools

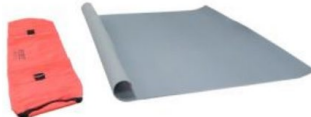
	<p>Engine Support Set -10-222B- (MRT)</p>		<p>Adapter -10-222A/14- Qty. = 2 (MRT)</p>
	<p>Module Lifting Aid -T10619- (MRT)</p>		<p>Lifting Tackle -3033- (MRT)</p>
	<p>Shock-Proof Protection (30 Pcs) -T10608- (MRT)</p>		<p>Shock-Proof Protection -T10628- Qty. = 3 (MRT)</p>
	<p>Removal Wedge Set -VAS895015- (MRT)</p>		<p>Engine Support - Bracket w/Spindle and hook -10-222A/10- (MRT)</p>
	<p>Shop Crane -VAS6100- (or equivalent)</p>		<p>Insulating Mat -VAS6762/44- (MRT)</p>













The repair information in this document is intended for use only by skilled technicians who have the proper tools, equipment and training to correctly and safely maintain your vehicle. These procedures are not intended to be attempted by "do-it-yourselfers," and you should not assume this document applies to your vehicle, or that your vehicle has the condition described. To determine whether this information applies, contact an authorized Volkswagen dealer. ©2023 Volkswagen Group of America, Inc. and Volkswagen Canada. All Rights Reserved.

	<p>Scissor Lift Table -VAS6131B- (or equivalent)</p>		<p>Engine Bung Set -VAS6122- (or equivalent)</p>
	<p>Leak-tight Connector -T10607- (MRT)</p>		<p>Digital Pressure Sensor -VAG1397B- (MRT)</p>
	<p>Pressure and Vacuum Pump -VAS671005- (MRT)</p>		<p>High Voltage Tool Set – Screwdriver -VAS6762/34-</p>
	<p>Cooling System Tester - Directional Valve -VAS691005/1- (component of MRT -VAS691005-)</p>		<p>High Voltage Tool Set - Torque Wrench -VAS6883/1A- (MRT)</p>
	<p>Template -T10606-</p>		<p>Cooling System Tester - Directional Valve -VAS691005/5- (component of MRT -VAS691005-)</p>
	<p>Cooling System Charge Kit -VAS6096- (MRT)</p>		

The repair information in this document is intended for use only by skilled technicians who have the proper tools, equipment and training to correctly and safely maintain your vehicle. These procedures are not intended to be attempted by "do-it-yourselfers," and you should not assume this document applies to your vehicle, or that your vehicle has the condition described. To determine whether this information applies, contact an authorized Volkswagen dealer. ©2023 Volkswagen Group of America, Inc. and Volkswagen Canada. All Rights Reserved.

 <p>B/1</p>	<p>Cooling System Tester -VAG1274B- (MRT)</p>		<p>Hose Clamps - Up To 25mm -3094- (or equivalent)</p>
	<p>Module Balancer -VAS6910- (MRT)</p>	 <p>/21-1 /21-2 /21-3 VAS6910/12B-2 VAS6910/12B-1</p>	<p>MEB Modules Expansion Set -VAS6910/21- (MRT)</p>
 <p>/1</p>	<p>Padlock -T40262/1- (from Service Disconnect Lock -T40262-)</p>		<p>Vehicle Diagnosis System - Connection Lead -VAS5051/66- (MRT)</p>
	<p>Pressure Sensor -VAS611013- (MRT)</p>	 <p>T10 T15 T20 T25 T27 T30 T40 T45 T50</p>	<p>Insulated Torx Wrench Set - 3/8 -VAS691003A- (MRT)</p>
 <p>/1 /3 /4 /2 /5 x2</p>	<p>*Extension Cables for High-Voltage Battery -VAS671007- (MRT)</p>	 <p>/11</p>	<p>*High Voltage Diagnostics Box -VAS5581A- (MRT)</p>
<p><b>*NOTE: Either -VAS671007- or -VAS5581A- may be used for this repair.</b></p>			

The repair information in this document is intended for use only by skilled technicians who have the proper tools, equipment and training to correctly and safely maintain your vehicle. These procedures are not intended to be attempted by "do-it-yourselfers," and you should not assume this document applies to your vehicle, or that your vehicle has the condition described. To determine whether this information applies, contact an authorized Volkswagen dealer. ©2023 Volkswagen Group of America, Inc. and Volkswagen Canada. All Rights Reserved.

 <p>High Voltage Test Adapter (without AFeS) -VAS6558A/35- (MRT)</p>	 <p>High Voltage Tool Set – Reversible Ratchet 3/8" -VAS6762/29- (MRT)</p>
 <p>High Voltage Tool Set – Extension 140mm -VAS6762/31- (MRT)</p>	 <p>Shackle (Equivalent to VAS691009A) -VAS691009US- Qty. = 8 (MRT)</p>
 <p>Diagnostic Tester -VAS6150X/6160X- (or equivalent)</p>	 <p>Battery Tester/Charger capable of <b>minimum 70 Amp</b> continuous supply</p>
 <p>Double Cartridge Adhesive Gun -VAS5237- (MRT)</p>	 <p>Female adapter for the -VAS5237- (based on shops preferred adapter style) (locally sourced)</p>
 <p>Pipe Brush -VAS294029- (or equivalent)</p>	 <p>Test Adapter - Hybrid Module -VAS6558A-</p>
 <p>Double Suction Lifter Qty. = 2 -VAG1344-</p>	 <p>High Voltage Tool Set – Screwdriver Insert XZN M10 -VAS6762/27- (MRT)</p>

The repair information in this document is intended for use only by skilled technicians who have the proper tools, equipment and training to correctly and safely maintain your vehicle. These procedures are not intended to be attempted by "do-it-yourselfers," and you should not assume this document applies to your vehicle, or that your vehicle has the condition described. To determine whether this information applies, contact an authorized Volkswagen dealer. ©2023 Volkswagen Group of America, Inc. and Volkswagen Canada. All Rights Reserved.



Cooling System Service  
Machine – TEXA  
-VAS531011KIT-

## Required Shop Materials



Cleaner D -009-401-04  
(shop supply)  
-OR-  
91% Isopropyl Alcohol  
(locally sourced)



Lint Free Towels  
(locally sourced)

***NOTE: Use only 91% Isopropyl alcohol as a cleaner (9% water). Do not use Isopropyl with any additional surfactants (cleaners) or additives (scents).***

## Repair Instruction

### Section A - Check for Previous Repair

#### TIP

If Campaign Completion label is present, no further work is required.

Applicable criteria ID(s)	Campaign/Action Status
01 	Open 

**EXAMPLE**

Campaign/Action	Start	Designation
	2015-11-10	W-SERV_ACT -
	2018-12-13	RECALL -
	2017-05-16	A-RECALL -

**EXAMPLE**

- Enter the VIN in Elsa and proceed to the “Campaign/Action” screen.

#### TIP

On the date of repair, print this screen and keep a copy with the repair order.

- Confirm the Campaign/Action is open <arrow 1>. If the status is closed, no further work is required.
- Note the Applicable Criteria ID <arrow 2> for use in determining the correct work to be done and corresponding parts associated.

 **STOP!** 

#### **NON-BATTERY REPAIR DEALERS:**

Proceed to Section B.

#### **BATTERY REPAIR DEALERS:**

Proceed to Section C.



## Section B – **NON-BATTERY REPAIR DEALERS ONLY**

### Perform GFF Test Plan to Check for Cell Modules with Increased Self-Discharge

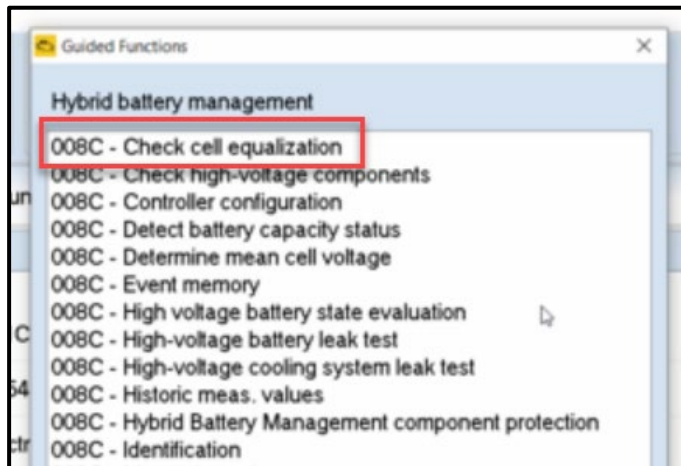

#### Check cell balancing and determine if any modules require replacement:

- Perform a diagnostic scan of the vehicle.
- Select the 008C Guided Functions test plan:
  - 008C – Check cell equalization
- Follow the test plan steps. The test plan will identify which (if any) additional cell module(s) will require replacement due to increased self-discharge.
- If the HV battery is OK and NO cell modules require replacement:
  - Proceed to Section D
- If the test plan indicates that a cell module requires replacement:
  - Send the diagnostic protocol to GFF Paperless.
  - Document which cell module requires replacement on the repair order.
  - **Non-battery repair dealers cannot perform the cell module replacement.**
  - **DO NOT apply the campaign completion label.**
  - The customer must be informed that a cell module requires replacement and an appointment will be required at a battery repair dealer.
  - **Work is complete for a non-battery repair dealer.**

## Section C – BATTERY REPAIR DEALERS ONLY

### Evaluating Which Cell Modules Require Replacement

- Criteria 02 vehicles have pre-identified cell modules which require replacement.
  - The serial number of the pre-identified cell module(s) that require replacement can be obtained using a feature in Elsa2Go.
  - Enter the affected VIN into Elsa2Go and navigate to the Campaigns/Actions section.
  - In the “Action” column, click on the “93P7 Serial #” link.

**Open Campaigns**

**Vehicle Data**

Model Name: ID.4 PRO S (Statement)  
 Sales Code: E214MN (FMC: E213MN)  
 Model Year: 2021  
 Production Date: 2021-07-26  
 Rear Engine Code(s): EBJA - EIP220-2.0/170 150kW 310Nm  
 Rear Trans. Code(s): UMF - EQ310-1P

**Dealer Data**

Delivery Date: 2021-08-27  
 Country: USA  
 Delivery Dealer: 401128

**Engine / Trans Configuration**

New Vehicle Limited Warranty  
 Provide Odometer Reading

**Campaigns / Actions** 1

Status	Code	Start	Description	Repair Date	Criteria ID	Status	Action
✓	93P7	2023-XX-XX	S-SERV_ACT - HV Battery Cell Modules		01	Open	<a href="#">93P7 Serial #</a>

Contracts & Subscriptions

**To determine which serial number(s) are affected by 93P7, please verify the VIN and select Submit.**

[CLOSE](#)

- Verify the VIN is correct and select Submit.

To determine which serial number(s) are affected by 93P7, please verify the VIN and select Submit.

**Affected Serial Numbers**

module\_07:LGP-POL21.07.20F6  
 module\_08:LGP-POL21.07.20F6

- If there are pre-identified cell module(s) that require replacement, the serial number(s) will be populated.
- Record the serial number(s) for the cell modules which require replacement.

**! IMPORTANT**

The cell module serial number listed indicates the module location. It is possible that this may not be the location of module with the affected serial number. Go by the cell module serial number and not the module location number.

To determine which serial number(s) are affected by 93P7, please verify the VIN and select Submit.

**Affected Serial Numbers**

no data available,  
 Perform ODIS test program "008C – Check cell equalization"

- If there are NO pre-identified cell module(s) that require replacement, a message will appear directing you to perform a GFF test plan to check for modules with increased self-discharge.
- Remember that ALL vehicles will require the test plan to check for modules with increased self-discharge.

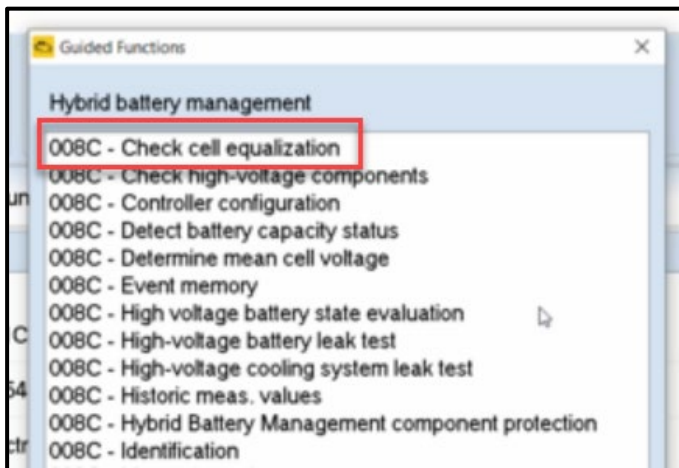

**Check cell balancing and determine if additional modules require replacement:**

**NOTE**

If a non-battery repair dealer already performed this inspection, the inspection must be performed again by the battery repair dealer to ensure all affected cell modules are replaced.

- Perform a diagnostic scan of the vehicle.
- Select the 008C Guided Functions test plan:
  - 008C – Check cell equalization
- Follow the test plan steps. The test plan will identify which (if any) additional cell module(s) will require replacement due to increased self-discharge.
- If additional cell modules require replacement, place the order for the additional parts and continue with this procedure once all parts have arrived.
- If no additional cell modules require replacement and all parts are available to complete this repair, continue with the next steps.

**NOTE**

It is possible that a cell module that requires replacement under the 93P7 (the serial # has already been identified), is the same module that failed the cell balancing test.

**NOTE**

If a module requires replacement due to increased self-discharge, the “Check cell equalization” test plan will prompt some important steps. Be sure to follow the test plan instructions and perform the additional steps in the correct order.

Note that information will be read from both the NEW and the OLD cell module(s).

The additional test plans should be populated under the Test Plan tab.

If the cell module(s) are not being replaced right away (i.e. parts have to be ordered), ensure these additional steps are carried out.

**Test step: Module change**

Action: Selection  
**Have the modules showing irregularities already been replaced?**

Entry: No

Action: Message  
After replacing the component, further steps are necessary.

The following software version was determined: [REDACTED]

- Make sure that the individual steps are in the correct sequence.

- 1) - Execute build status documentation.
- 2) - Software version management/control modules software configuration -> 2. SWK via action code -> [REDACTED]
- 3) - Software version management/control modules software configuration -> 1. SWC via diagnostic address -> 8C

All programs are listed in the suspect list.

- Press the Complete/Continue button to end.

Offboard Diagnostic Information System Service - 9.1.0 (Confidentiality level: confidential)

Importer: Read measured values

Measurement name	ID	Value
▼ minimum voltage for battery cells	IDE08218	
Value	MAS02985	
Index 1	MAS01234	24
▼ maximum voltage for battery cells	IDE08217	
Value	MAS02985	
Index 1	MAS01234	

### Perform cell balancing on new cell module:

- Check Measured Value Block (MVB) “maximum voltage for battery cells, IDE08217.
- The voltage reading listed will be entered in the DSS Manager program when balancing the new cell module.

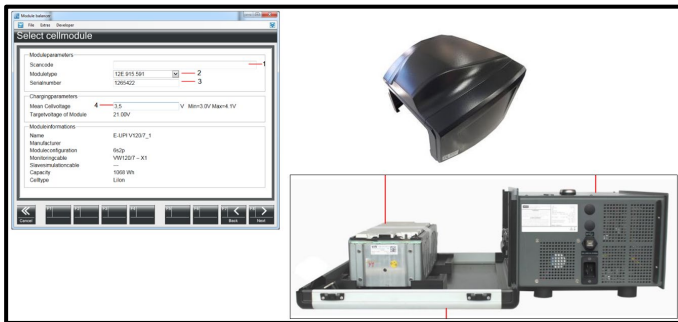

- Follow the VAS6910 operating instructions in conjunction with the DSS Manager program to perform the cell balancing on the new cell module.

### TIP

Operating instructions for the VAS6910 and DSS Manager program can be found on the VW Special Tools and Equipment website.

Tests in current test plan

Status	Tests (sorted according to chances of success)
🔵	008C - High-voltage cooling system leak test
🔵	008C - Controller configuration
🟢	008C - High-voltage battery leak test
🟢	High-voltage system, de-energize
🟡	HV measurement module VAS6558/VAS6558A
🟢	008C - Measuring values
🔵	008C - Identification
🟢	008C - Event memory

### Populate Guided Functions test plans:

- Perform a diagnostic scan of the vehicle.
- Select “Self Test” and populate the following Guided Function test plans:
  - High-voltage system, de-energize
  - 008C – High-voltage battery leak test
  - HV measurement module VAS6558/6558A

Tests in current test plan	
Status	Tests (sorted according to chances of success)
	008C - High-voltage cooling system leak test
	008C - Controller configuration
	008C - High-voltage battery leak test
	High-voltage system, de-energize
	HV measurement module VAS6558/VAS6558A
	008C - Measuring values
	008C - Identification
	008C - Event memory

## De-energize the high-voltage system:

**DANGER**

**High voltage increases the risk of fatal injury**  
**Electrocution can cause severe bodily or fatal injury**

Have a high-voltage technician or a high-voltage expert de-energize the high-voltage system.

- Follow the Guided Functions test plan steps.
- Pay close attention to all of the test plan steps.

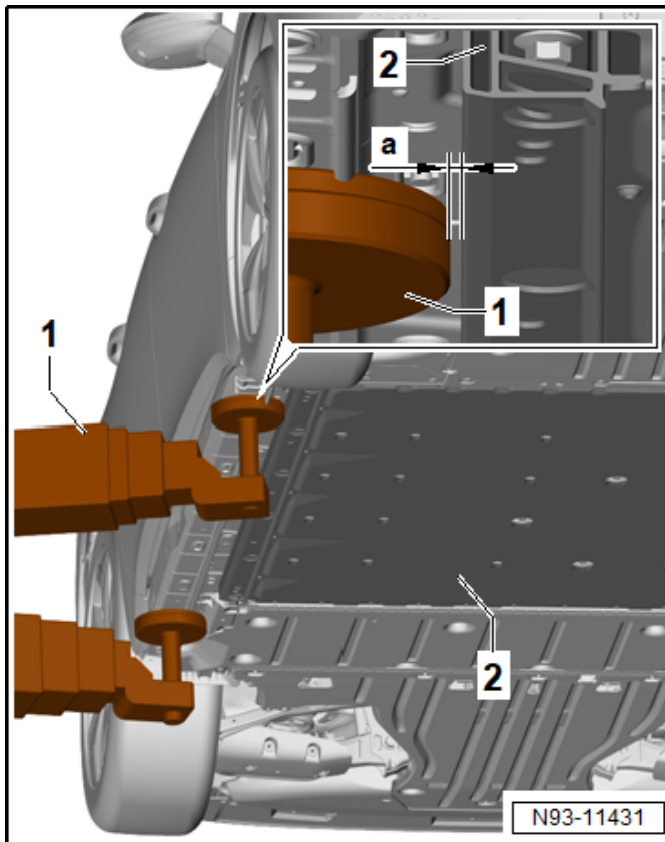

## Raise the vehicle:

**TIP**

Removal of the high-voltage battery is not possible on all hoists. Make sure that there is enough clearance. Pay attention that the high-voltage battery has enough clearance <a> during the lifting process so that the Scissor Lift Table -VAS6131B- can be set down.

- Pivot in the hoist with the vehicle support plate <1> on the frame of the high-voltage battery <2>. Then pivot back the hoist arm with the vehicle support plate <1> <a> so that the high-voltage battery <2> can be lowered in the next steps.

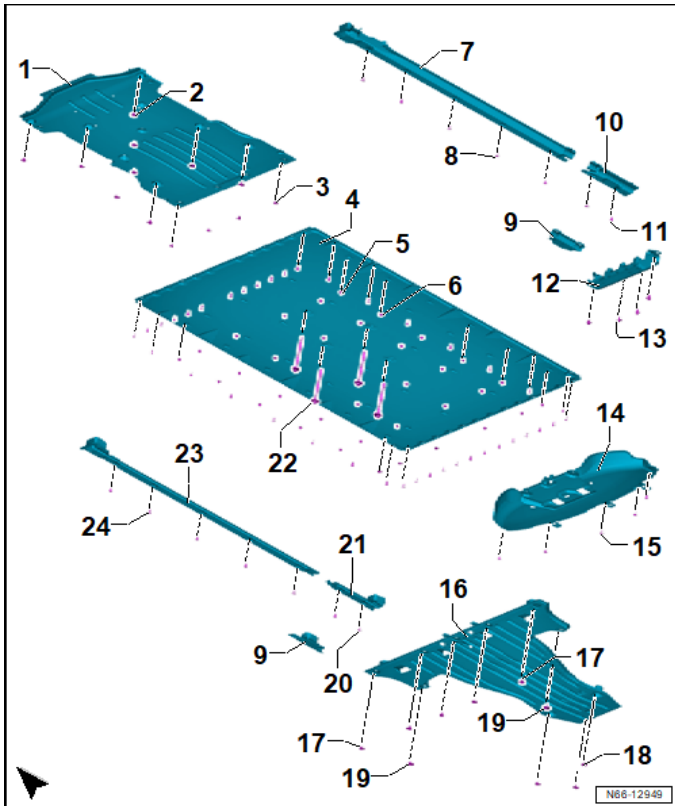

### Remove lower covers:

- Reference ELSA Repair Manual.
- Remove the front underbody trim panel <1>. Refer to → *Body Exterior; Rep. Gr.66; Underbody Trim Panel; Front Underbody Trim Panel, Removing and Installing.*
- Front wheel housing liner, loosening in the area of the high-voltage battery threaded connection. Refer to → *Body Exterior; Rep. Gr.66; Wheel Housing Liner; Front Wheel Housing Liner, Removing and Installing.*
- Remove the side underbody trim panels. Refer to → *Body Exterior; Rep. Gr.66; Underbody Trim Panel; Side Underbody Trim Panel, Removing and Installing.*
- Remove the rear center underbody trim panel <16>. Refer to → *Body Exterior; Rep. Gr.66; Underbody Trim Panel; Rear Center Underbody Trim Panel, Removing and Installing.*
- Remove the rear underbody trim panel <14>. Refer to → *Body Exterior; Rep. Gr.66; Underbody Trim Panel; Rear Underbody Trim Panel, Removing and Installing.*

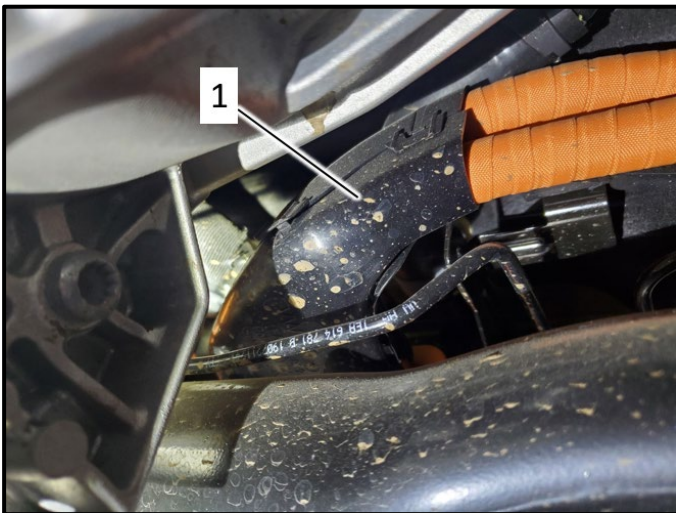

### Perform high-voltage battery leak test:

- Before disconnecting the high-voltage battery connectors, remove the protective covers <1> from both of the connectors first.



Tests in current test plan	
Status	Tests (sorted according to chances of success)
	008C - High-voltage cooling system leak test
	008C - Controller configuration
	008C - High-voltage battery leak test
	High-voltage system, de-energize
	HV measurement module VAS6558/VAS6558A
	008C - Measuring values
	008C - Identification
	008C - Event memory

- See ELSA Repair Manual: *Repair Manual > Motor > Electric Drive Rear Wheel Drive EIP220 and All Wheel Drive EIA200, EIP220 > 93 Electric drive > High-Voltage Battery Unit > High-Voltage Battery 1 AX2 Leak Test*
- Perform these steps in conjunction with Guided Function test plan, “008C – High-voltage battery leak test.”

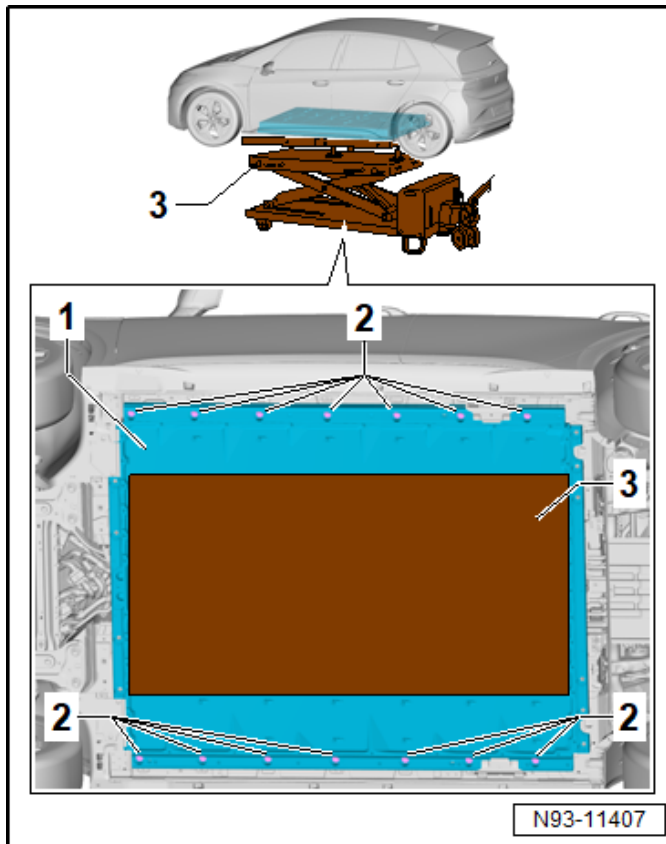

### Remove high-voltage battery:

- See ELSA Repair Manual: *Repair Manual > Motor > Electric Drive Rear Wheel Drive EIP220 and All Wheel Drive EIA200, EIP220 > 93 Electric drive > High-Voltage Battery Unit > High-Voltage Battery 1 AX2 , Removing and Installing, 82 kWh*
- Note the following when removing the high-voltage battery:
  - Mark the position of the scissor lift table on the floor to aid in re-positioning the table during reinstallation.
  - Pay close attention to all wiring harnesses when lowering the battery.
  - Pay close attention to coolant hoses when lowering the battery.

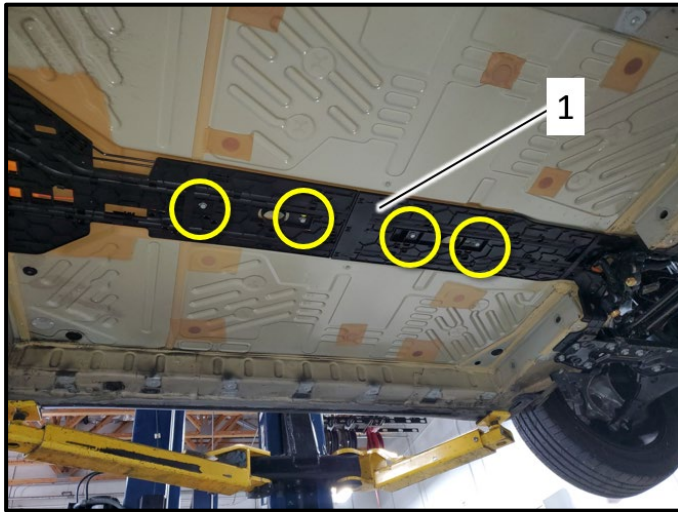

#### Secure media duct/channel (if necessary):

- If the media duct/channel <1> had not yet been secured, install new bolts <circles> and torque to 20 Nm.

Part Number	Part Description
N -102-252-02	Bolt

#### NOTE

If the media channel is already secured with bolts, the bolts do not have to be replaced again.

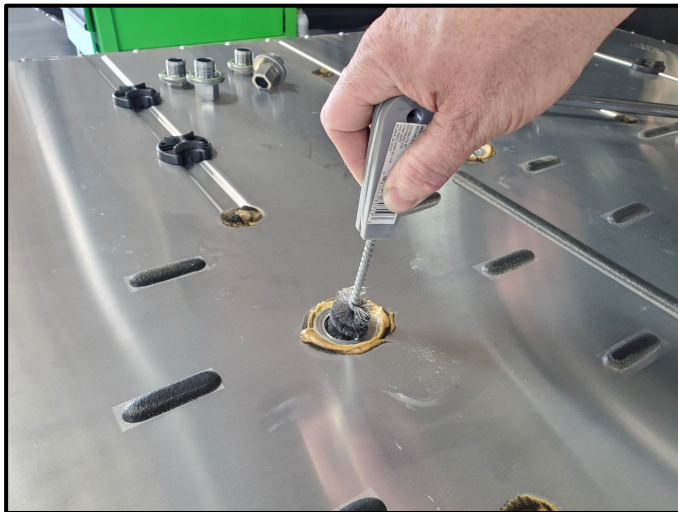

#### Clean high-voltage battery cover:

- Vacuum all loose dirt and debris from high-voltage battery.
- Clean the connection element threads using pipe brush -VAS294029- (or equivalent) as shown.

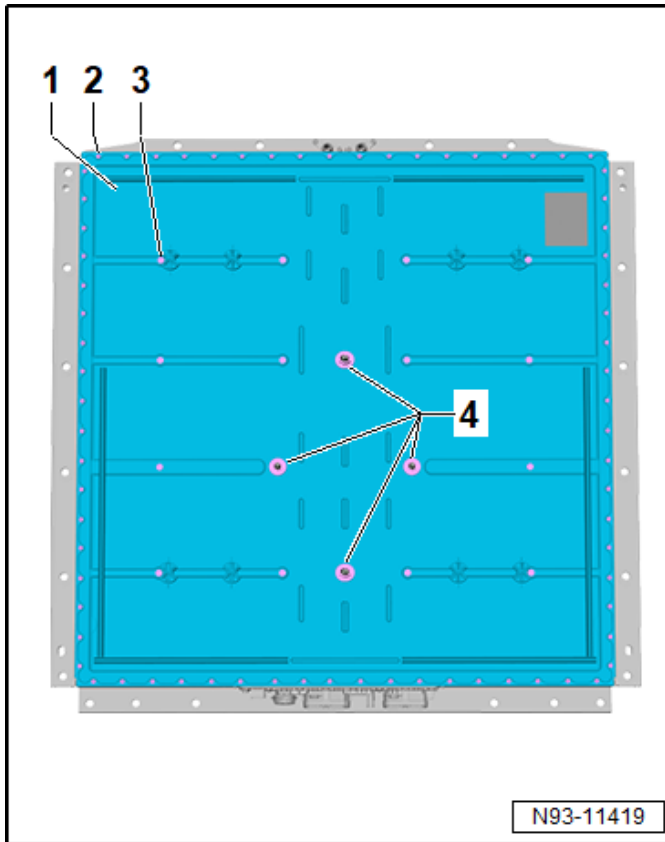

**Remove high-voltage battery cover:**

- **USE HAND TOOLS ONLY!**
- See ELSA Repair Manual: *Repair Manual > Motor > Electric Drive Rear Wheel Drive EIP220 and All Wheel Drive EIA200, EIP220 > 93 Electric drive > High-Voltage Battery Unit > High-Voltage Battery 1 AX2 , Opening*

**⚠ DANGER**

**High voltage increases the risk of fatal injury  
Electrocution can cause severe bodily or fatal injury**

Pay close attention to which Repair Manual steps require Personal Protective Equipment.

**ⓘ NOTE**

The upper part of battery housing can be reused under certain circumstances and does not have to be replaced.

To determine if the cover can be reused, refer to the ELSA Repair Manual: *Repair Manual > Motor > Electric Drive Rear Wheel Drive EIP220 and All Wheel Drive EIA200, EIP220 > 93 Electric drive > High-Voltage Battery Unit > Battery Housing Upper Section, Checking for Re-Use*

### Identify cell module which requires replacement:

- Identify the module that requires replacement and clearly mark its location.



### NOTE

If the serial number cannot be found on any of the cell modules, it is possible the module was replaced on a previous service visit.

If the serial number cannot be found on any of the cell modules, create a VTA [WEB](#) ticket and wait for further instructions. Include photos of the serial numbers for each of the 12 cell modules and the high-voltage battery identification/part number label.

Example of high-voltage battery identification, located on one end of the high-voltage battery case:

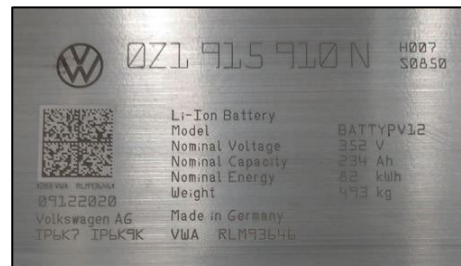

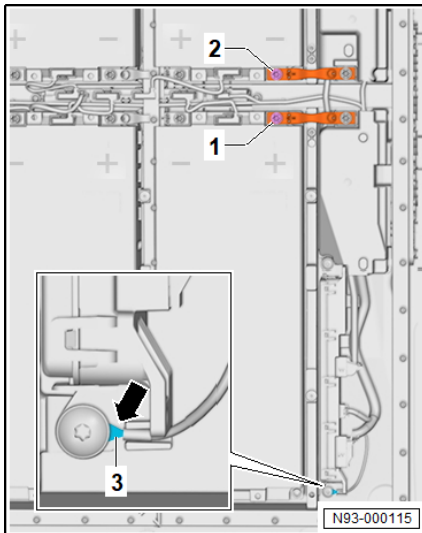

### Perform insulation measurement:

- Perform insulation measurement according to ELSA Repair Manual: *Repair Manual > Motor > Electric Drive Rear Wheel Drive EIP220 and All Wheel Drive EIA200, EIP220 > 93 Electric drive > High-Voltage Battery Unit > Voltage and Insulation Measurement, 82 kWh*
- Perform the measurement in conjunction with ODIS test plan, "HV measurement module VAS6558/VAS6558A."

Tests in current test plan	
Status	Tests (sorted according to chances of success)
	008C - High-voltage cooling system leak test
	008C - Controller configuration
	008C - High-voltage battery leak test
	High-voltage system, de-energize
	HV measurement module VAS6558/VAS6558A
	008C - Measuring values
	008C - Identification
	008C - Event memory



### Clean high-voltage battery sealant off of lower housing:

- Clean old sealant using a lint free cloth and Cleaner D -009-401-04 or isopropyl alcohol.

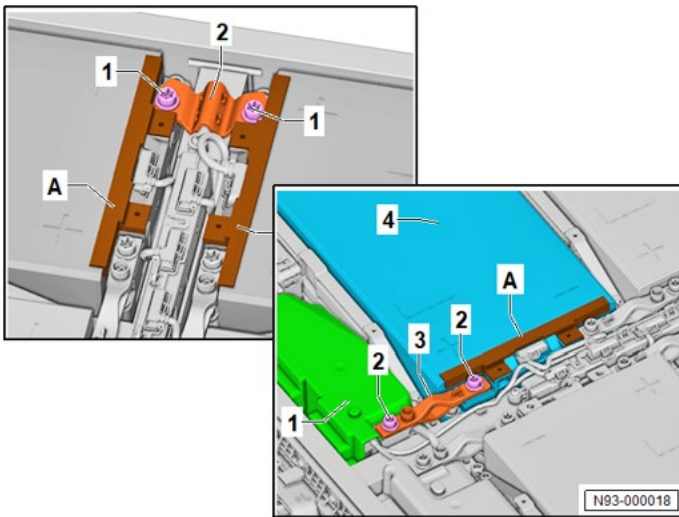

### Disconnect the high-voltage circuit:

- See ELSA Repair Manual: *Repair Manual > Motor > Electric Drive Rear Wheel Drive EIP220 and All Wheel Drive EIA200, EIP220 > 93 Electric drive > High-Voltage Battery Unit > Circuit, Disconnecting, 82 kWh*

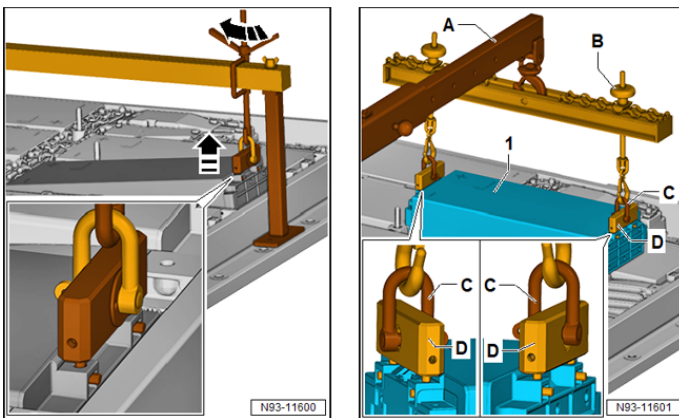

### Remove the cell module:

- See ELSA Repair manual: *Repair Manual > Motor > Electric Drive Rear Wheel Drive EIP220 and All Wheel Drive EIA200, EIP220 > 93 Electric drive > High-Voltage Battery Components > Battery Module, Removing*
- Ensure the shock protection is installed on ALL open high-voltage connections.

### TIP

Pay close attention to the wiring harnesses, so they are not damaged or pinched during removal.

The cell module can be freed from the adhesive bond from either end of the cell module.



### Clean the mounting area for the new cell module:

- When cleaning the cell module mounting area, use extreme care so the sealant for the high-voltage battery splines and lower housing is not damaged and that no cleaners come into contact with the sealant.
- Vacuum any loose debris from the mounting area of the cell module.
- Clean cell module mounting area with Cleaner D -009-401-04 or isopropyl alcohol and allow it to completely dry.
- Do not allow the cleaner to come in contact with any of the lower housing frame sealant.

### Installing new cell module(s):

- Reference ELSA Repair manual: *Repair Manual > Motor > Electric Drive Rear Wheel Drive EIP220 and All Wheel Drive EIA200, EIP220 > 93 Electric drive > High-Voltage Battery Components > Battery Module, installing*
- Note the following when installing the new cell module(s):
- Peel off the protective backing and apply the separating foil <arrow> as needed along the outer frame edges, in the area where the cell module is mounted.



Part Number	Part Description
0Z1-998-474	Separating foil/film

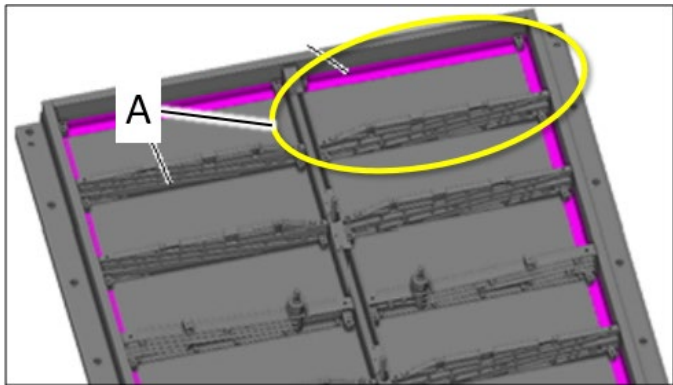

- If the cell module being replaced is in the corner of the high-voltage battery, the separating foil must be applied to both outer frame edges as shown in area <A>.

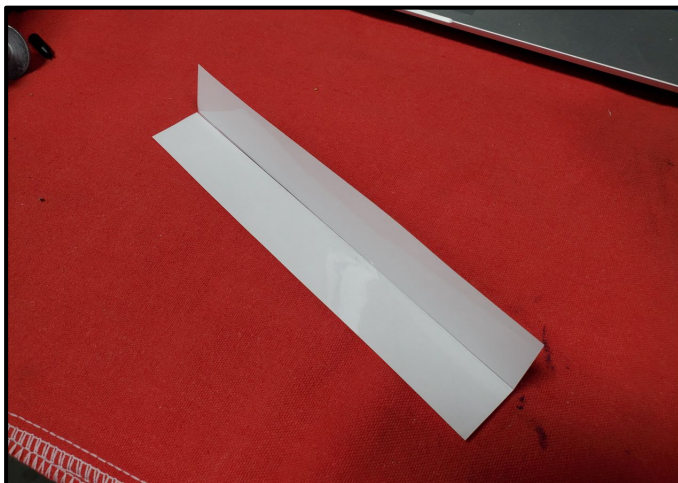

#### TIP

Having a second technician pre-fold the separating film before installing will aid in applying the film.



- Clean the bottom of the cell module using Cleaner D -009-401-04 or isopropyl alcohol and allow it to dry completely.



- Double check the expiration date of the paste before applying.
- Use Double Cartridge Adhesive Gun -VAS5237- to apply the heat paste.

Part Number	Part Description
D -G00-018-M3	Heat paste

- Before applying the heat paste, release a small amount through the applicator to ensure the paste is mixing properly.



- When filling Template -T10606-, ALL of the heat paste must be used.



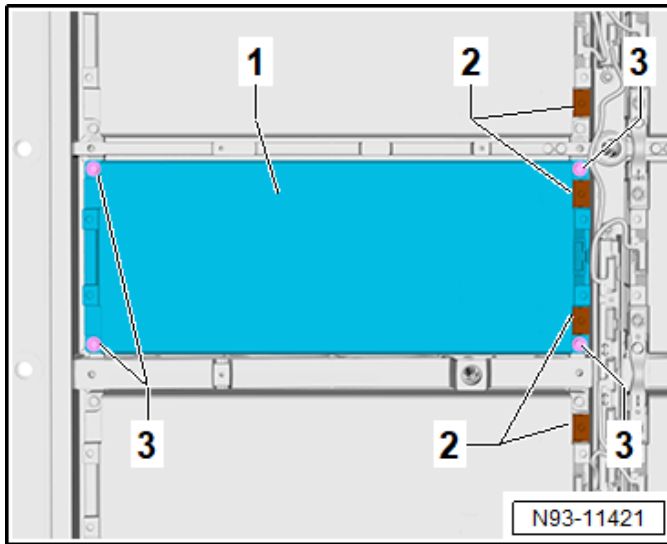

- Pay close attention to the wiring harnesses when installing the cell module.
- Torque new bolts <3> in a cross pattern to 16 Nm + 180°.

Part Number	Part Description
N -912-809-01	Bolt

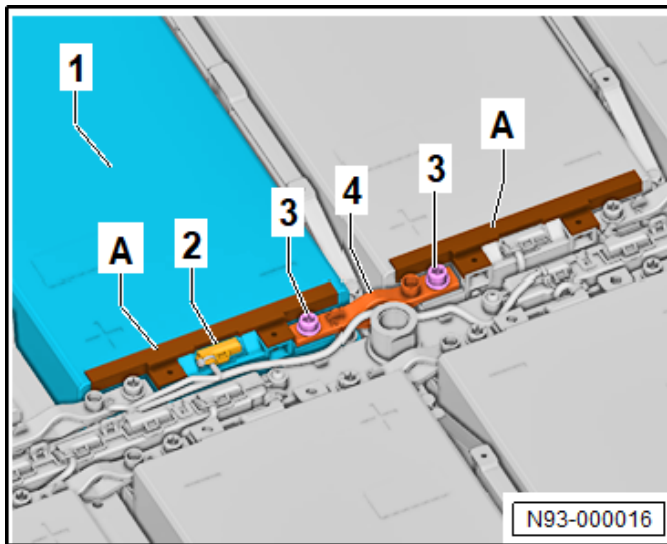

- Torque bolts <3> for the high-voltage connection <4> to 8 Nm.



**⚠ DANGER**

**STOP STOP!**

**Incorrect installation of battery modules and module connectors.**

**Short circuit electric arc can cause severe bodily or fatal injuries.**

Check the battery modules and module connectors for correct installation.

Only continue with the procedure when there is no voltage in between the battery terminals.

Pay very close attention to the Repair Manual steps outlining the use of the -VAS6762/45-.

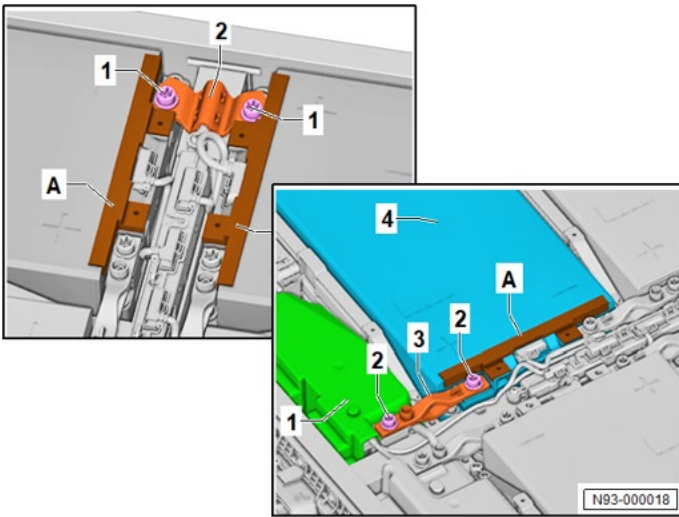

**Reconnect high-voltage circuit:**

- Reconnection is the reverse order of disconnecting.
- Reference ELSA Repair Manual: *Repair Manual > Motor > Electric Drive Rear Wheel Drive EIP220 and All Wheel Drive EIA200, EIP220 > 93 Electric drive > High-Voltage Battery Unit > Circuit, Disconnecting, 82 kWh*



**Check for high-voltage battery faults:**

- Using -VAS671007- or -VAS5581A-, in conjunction with the Diagnostic Tester, verify there are no faults stored for any high-voltage battery component before installing the high-voltage battery cover.

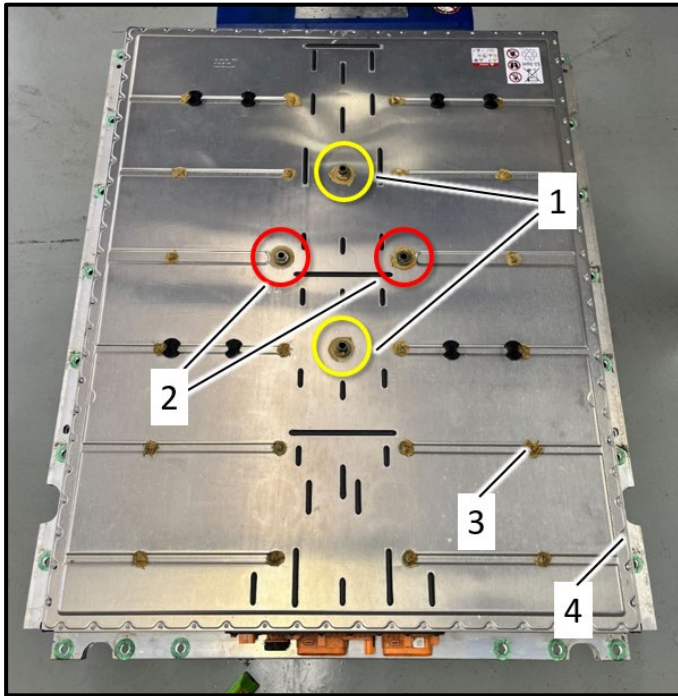

## Install and seal high-voltage battery cover:

### NOTE

The upper part of battery housing can be reused under certain circumstances and does not have to be replaced.

To determine if the cover can be reused, refer to the ELSA Repair Manual: *Repair Manual > Motor > Electric Drive Rear Wheel Drive EIP220 and All Wheel Drive EIA200, EIP220 > 93 Electric drive > High-Voltage Battery Unit > Battery Housing Upper Section, Checking for Re-Use*

### TIP

Ensure all shock protection is removed prior to installing cover.

Pay attention to the cover position. The cover part number stamping is positioned at the front of the high-voltage battery.

- SEE ELSA Repair Manual: *Repair Manual > Motor > Electric Drive Rear Wheel Drive EIP220 and All Wheel Drive EIA200, EIP220 > 93 Electric drive > High-Voltage Battery Unit > High-Voltage Battery 1 AX2 , Sealing, 82 kWh*

Part Number	Part Description
1EA-804-841-AC	Cover (if necessary)
D -454-300-H2	Sealant
1EA-802-131-A	Connection element (qty. 2) Position <1>
1EA-802-132-A	Connection element (qty. 2) Position <2>
WHT-008-738-A	Middle bolts (qty. 22) Position <3>
WHT-009-218	Perimeter bolts (qty. 82) Position <4>

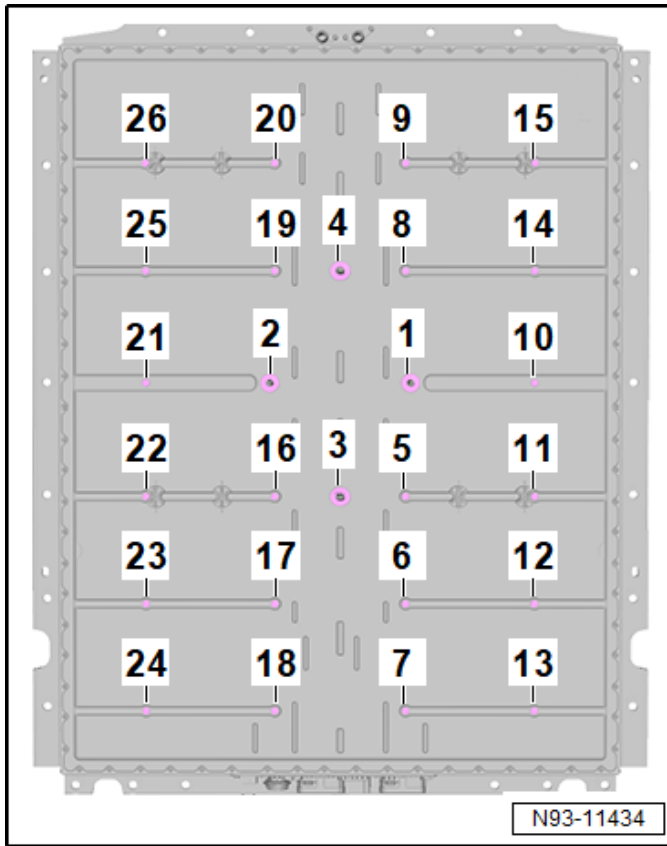

- Torque the new fasteners in the following order:
  1. Connection element bolts <1 through 4> to 100 Nm.
  2. Middle bolts <5 through 26> to 5.5 Nm + 90°.

**TIP**  
Utilize a second technician to keep track of, or mark each bolt once it has been torqued.

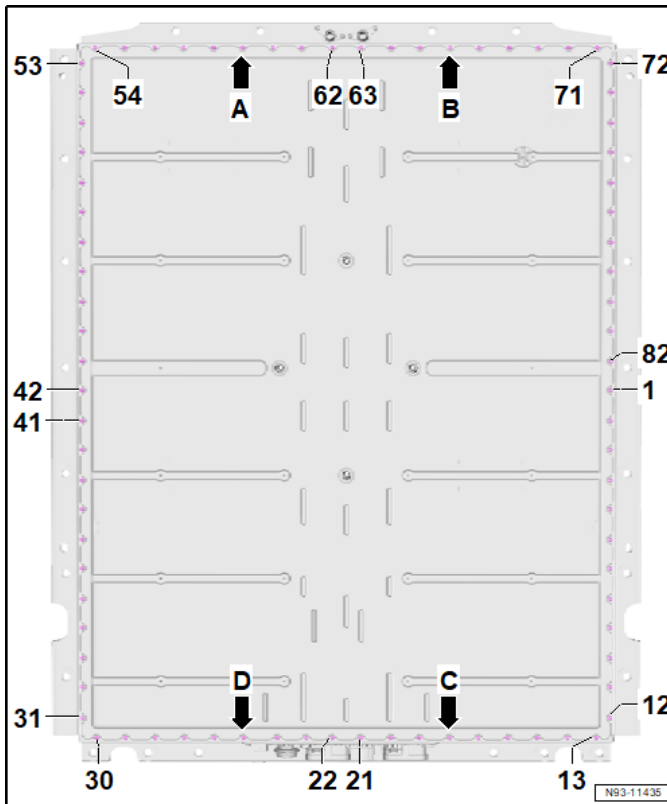

3. Bolts <A, B, C and D> to 8 Nm.
4. Bolts <1 through 82> to 8 Nm.

Tests in current test plan	
Status	Tests (sorted according to chances of success)
	008C - High-voltage cooling system leak test
	008C - Controller configuration
	008C - High-voltage battery leak test
	High-voltage system, de-energize
	HV measurement module VAS6558/VAS6558A
	008C - Measuring values
	008C - Identification
	008C - Event memory

### Perform high-voltage battery leak test:

- See ELSA Repair Manual: *Repair Manual > Motor > Electric Drive Rear Wheel Drive EIP220 and All Wheel Drive EIA200, EIP220 > 93 Electric drive > High-Voltage Battery Unit > High-Voltage Battery 1 AX2 Leak Test*
- Perform these steps in conjunction with Guided Function test plan, “008C – High-voltage battery leak test.”

### Prepare high-voltage battery for installation:

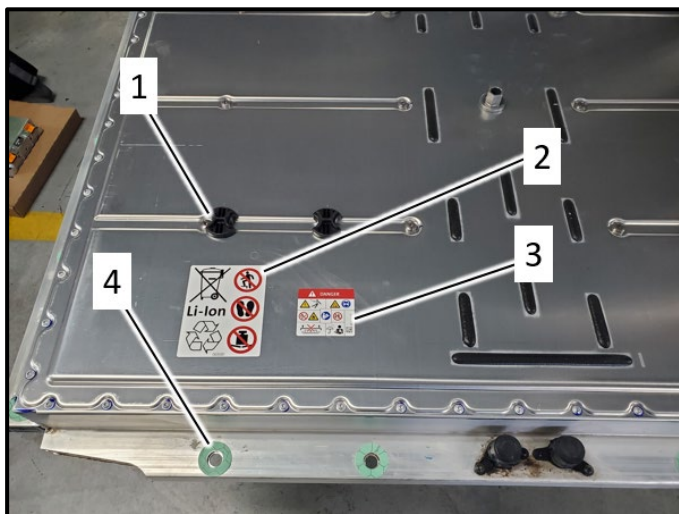

#### NOTE

Replacing the spacers and stickers is only necessary if the high-voltage battery cover is replaced.

- Install new spacers <1> (qty. 8) onto the high-voltage battery cover. Reference the old cover for installation position if needed.
- Apply new sticker <2> and warning sign <3>.
- Remove old separating film <4> from around the high-voltage battery mounting holes and install new separating film.
  - Do not install separating film if there was no existing film already in place.

Part Number	Part Description
1EA-804-973	Spacer (qty. 8)
1EA-998-103	Separating film
12E-010-006-AA	Sticker
1EA-010-505	Warning sign

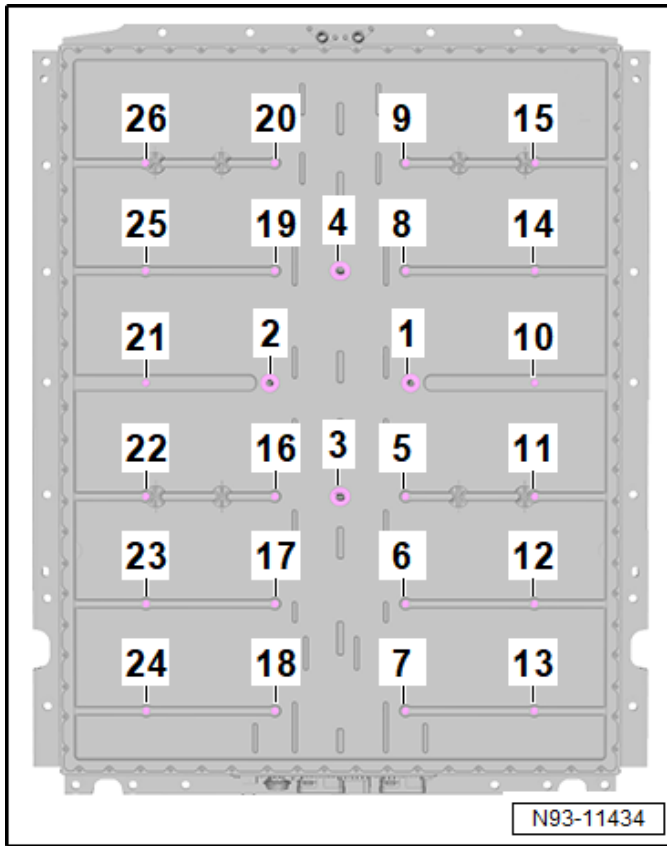

- Apply wax around the base of the connection elements <1 through 4>.
- Completely cover all (22) middle bolts <5 through 26> with wax.

Part Number	Part Description
D -316-000-A1	Wax/Undercoat

**COVERAGE DETAIL**

Connection elements <1 through 4>	
Middle bolts <5 through 26>	

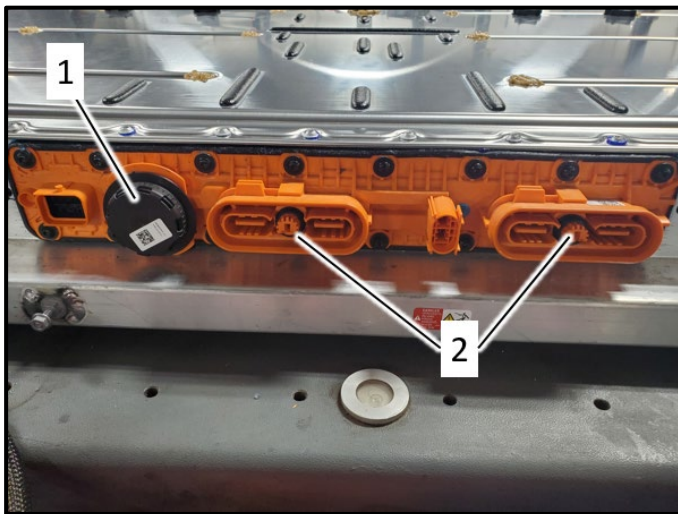

- Install new pressure relief valve <1> and connection seals <2>.

Part Number	Part Description
1HV-915-754-A	Valve
0Z1-915-433-A	Seal (qty. 2)

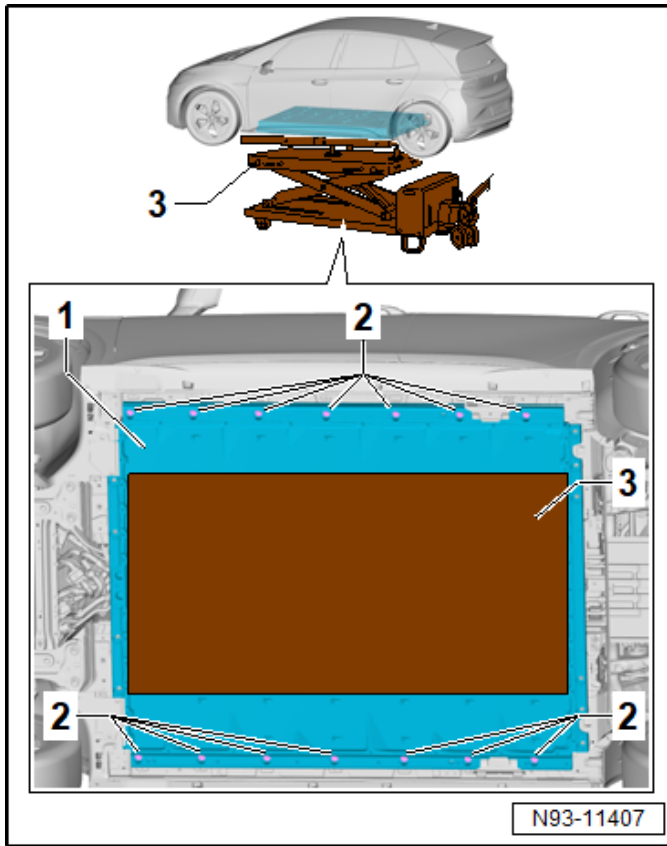

### Re-install high-voltage battery:

- Installation is the reverse order of removal.
- See ELSA Repair Manual: *Repair Manual > Motor > Electric Drive Rear Wheel Drive EIP220 and All Wheel Drive EIA200, EIP220 > 93 Electric drive > High-Voltage Battery Unit > High-Voltage Battery 1 AX2 , Removing and Installing, 82 kWh*
- Use new bolts.

Part Number	Part Description
N -912-832-01	Center bolts (qty. 4)
N -909-428-04	Perimeter bolts (qty. 24)

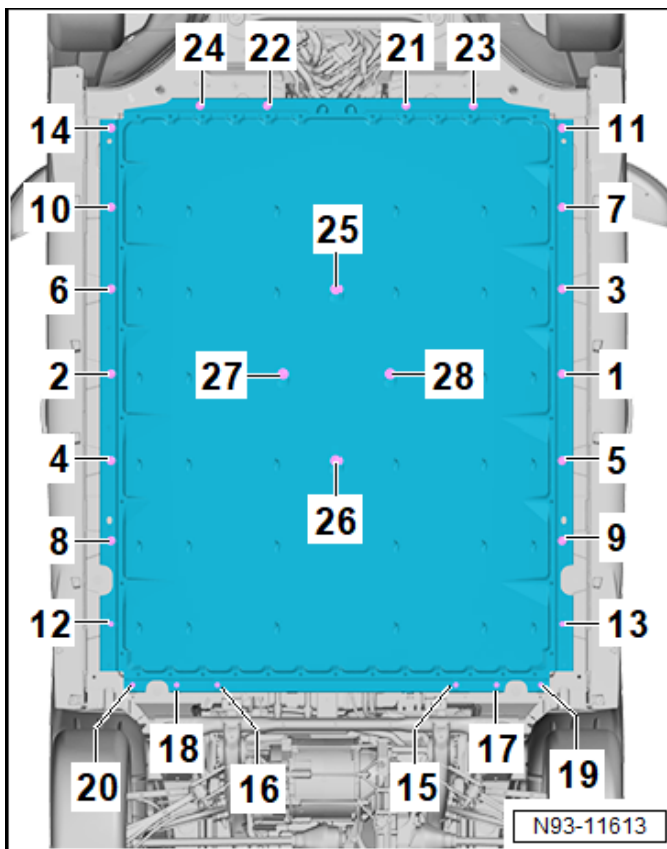

- Torque the new bolts in the following sequence:
  1. Bolts <1 through 24> to 50 Nm + 90°.
  2. Bolts <25 through 28> to 40 Nm + 180°.

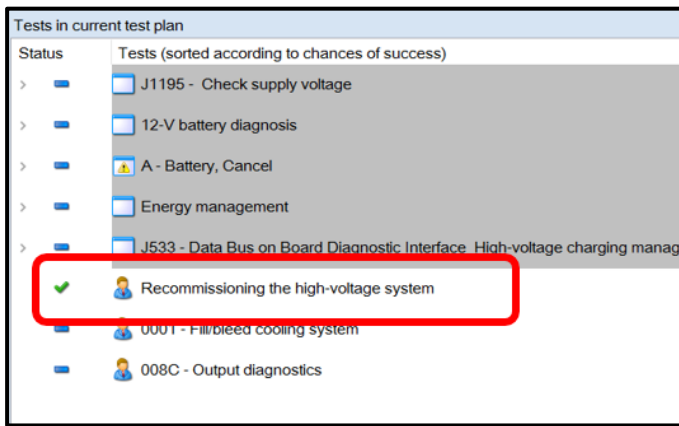

## Recommission the high-voltage system:



**High voltage increases the risk of fatal injury**  
**Electrocution can cause severe bodily or fatal injury**

Have a high-voltage technician or a high-voltage expert recommission the high-voltage system.

- Follow the Guided Functions test plan steps.
- Pay close attention to all of the test plan steps.

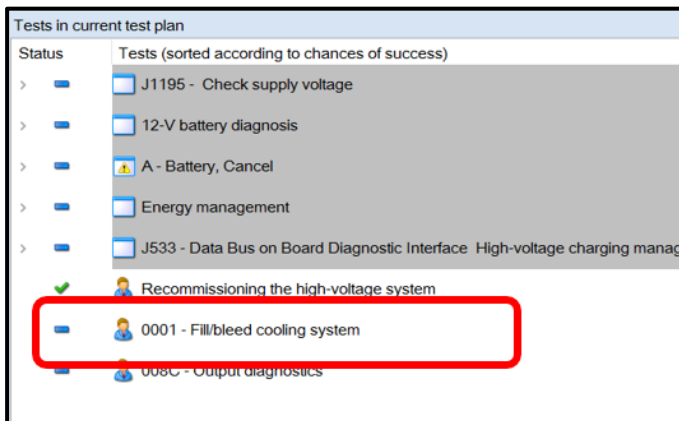

## Fill cooling system

(option 1 – without VAS531011):

- Top off coolant.
- Select “Self Test” and populate test plan, “0001 – Fill/bleed cooling system.”



- Connect the Cooling System Tester -VAG1274B- and create a pressure of 1.0 bar using the hand pump.
- Run the test plan “0001 – Fill/bleed cooling system” and follow the on-screen prompts.
- Once the test is successfully completed, repeat the test plan a second time.
- Top off coolant.





## Fill cooling system

(option 2 – with VAS531011):

- See ELSA Repair Manual: *Repair manual > Motor > Electric Rear Wheel Drive EIP220 and All Wheel Drive EIA200, EIP220 > 19 Cooling System > Cooling System/Coolant > Cooling System, Filling > Cooling System, Filling with Cooling System Service Station VAS 531 011*

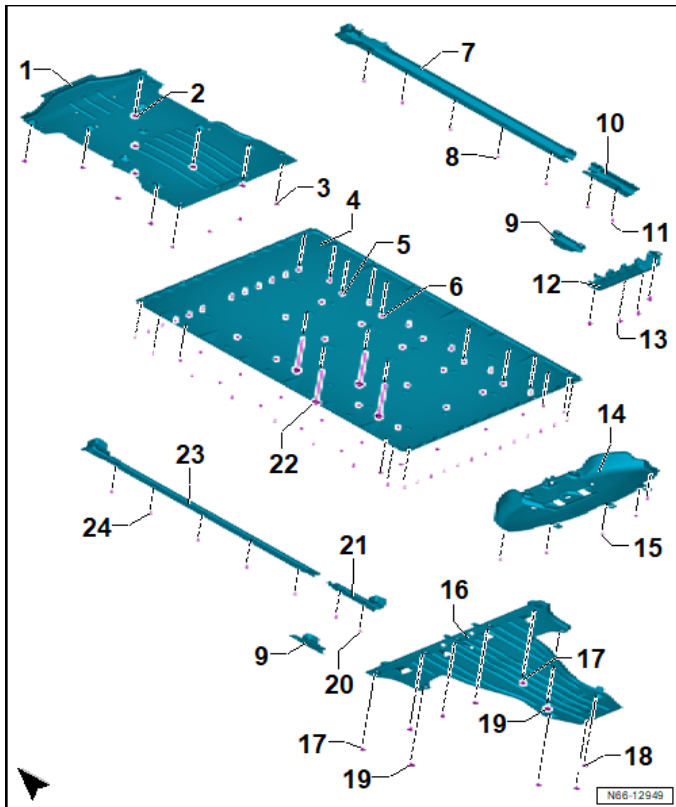

## Reinstall underbody covers and side covers:

- Installation is the reverse order of removal.
- Reference the ELSA Repair Manual as needed.
- Replace any damaged fasteners.

## Clear repair related faults:

- Exit GFF and send the diagnostic protocol to GFF paperless.

## Proceed to Section D

## Section D – Campaign Completion Label

### Install Campaign Completion Label

- Fill out and affix Campaign Completion Label, part number CAMP 010 000, next to the vehicle emission control information label.

 **TIP**

Ensure Campaign Completion Label does not cover any existing label(s).

**US DEALERS - Proceed to Section E**

**CANADIAN DEALERS - Proceed to Section F**

## Section E - Parts Return/Disposal – US DEALERS ONLY

### High-Voltage Cell Modules:

Replaced High-Voltage Cell Modules or Batteries must be recycled through Redwood Materials.

If the request appears in the Scrap / Core / Recycle tab of the Warranty Parts Portal (WPP):

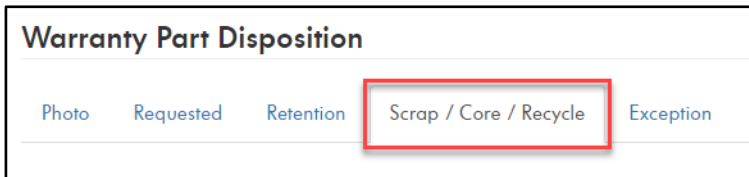

Refer to the HV Battery Recycling Program information found in ServiceNet: *ServiceNet > Electric/PHEV Vehicles*

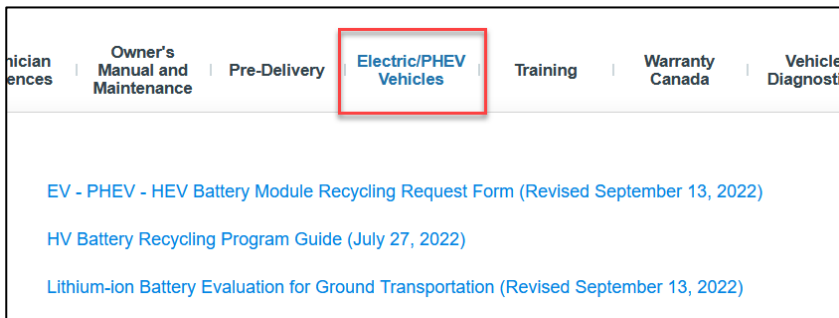

If the request appears in the "Requested" tab in the Warranty Parts Portal (WPP) with Service Type "Redwood":



Process the request to generate the EV-PHEV-HEV Battery Recycling Request form. Follow the directions on the form to initiate the recycling return with Redwood Materials. Additional information can be found in ServiceNet: ServiceNet > Electric/PHEV Vehicles as above.

### All other parts:

Properly store (retain), destroy or dispose of removed parts in accordance with all state/province and local requirements, unless otherwise indicated and/or requested through the Warranty Parts Portal (WPP).

## **Section F - Parts Return/Disposal – CANADIAN DEALERS ONLY**

### **High-Voltage Cell Modules:**

Refer to the latest version of TSB 2060231

### **All other parts:**

Properly store (retain), destroy or dispose of removed parts in accordance with all state/province and local requirements, unless otherwise indicated and/or requested through the Part Destruction and Core Disposition Report for Canada.