

TECHNICAL SERVICE BULLETIN

Bulletin No.: TSB-048
Date: April 7, 2023
Subject: VP Cylinder PRD Mounting Bracket
Models: Select Quantum Virtual Pipeline Lite Trailers

Background

Each CNG storage cylinder in Quantum Virtual Pipeline (VP) trailers is equipped with its own thermally activated Pressure Relief Device (PRD). The PRD body is mounted on the cylinder cross member using a bracket. The PRD assembly is connected to the cylinder gas volume using a stainless-steel pipe that enters the PRD body from the top.

Condition

In some cases, the PRD body may be mounted too high causing the PRD inlet pipe supplying gas to the PRD assembly to contact or rub the roof panel.

Cause

Variation in the PRD bracket mounting hole location in the cross member may result in the PRD assembly installation height being too high resulting in contact between the roof panel and PRD inlet pipe.

Correction

Inspect the clearance between the roof panel and the PRD inlet pipes following the inspection procedure outlined in this document.

If the clearance is found to be less than the specified minimum, replace the PRD mounting bracket with an adjustable PRD mounting bracket following the procedure in this bulletin.

TECHNICAL SERVICE BULLETIN

Labor Time

Labor OP: TSB048-01	Labor Op Desc.: PRD inlet pipe Insp, All	Time: 1.5 Hrs
Labor OP: TSB048-02	Labor Op Desc.: PRD Brkt RH R&R, Each Includes roof panel R&R	Time: 1.5 Hrs
	Add: for PRD Brkt CTR R&R	Time: 0.5 Hrs
	Add: for PRD Brkt LH R&R	Time: 0.3 Hrs
	Add: for PRD inlet pipe R&R	Time: 4.0 Hrs

Parts Information

Description	Part Number	Qty
BRACKET-PRD MT, RH	118432	A/R
BRACKET-PRD MT, LH	118433	A/R
BRACKET-PRD MT, CENTER	118434	A/R
BRACKET-PRD MT, LH ROW 1 45' *	118438	A/R
BRACKET-PRD MT, CTR ROW 1 45' *	118439	A/R
BRACKET-PRD MT, RH ROW 1 *	118437	A/R
O-RING-ORFS-6, LOW TEMP	117997-012	A/R
O-RING-ORFS-8, LOW TEMP	117997-014	A/R
PIPE ASM-INLET, PRD, VP, RH	117956	A/R
PIPE ASM-INLET, PRD, VP, CTR	117890	A/R
PIPE ASM-INLET, PRD, VP, LH	117952	A/R
PIPE ASM-INLET, PRD, VP *	117960	A/R
PIPE ASM-INLET, PRD, VP, CTR, ROW 1, 45' *	117963	A/R
PIPE ASM-INLET, PRD, VP, RH, ROW 1 *	117958	A/R

* Used on row 1 cross member assembly of 45', Gen 1-5 trailers only.

Revised brackets and pipe assemblies to complete this repair will be available beginning in early May 2023.

Application

All Quantum 20' VP trailers Gen 1
 All Quantum 40' VP trailers Gen 1-3
 All Quantum 45' VP trailers Gen 1-7

Contact Information:

E-Mail: QTService@qtw.com
 Phone: 800.816.8691
 Fax: 949.930.3401

TECHNICAL SERVICE BULLETIN

The same crossmember assembly is used throughout most of the trailer, but the crossmember assembly will be rotated for every other row.

The actuator valve location will switch from the lefthand side of the trailer to the righthand side of the trailer.

For the purposes of this document and part identification, bracket and cylinder orientation is determined by the valve end of the cross member; the valve end of the cross member is always considered the RH side regardless of orientation in the trailer. See the illustrations below:

LEFT CENTER RIGHT

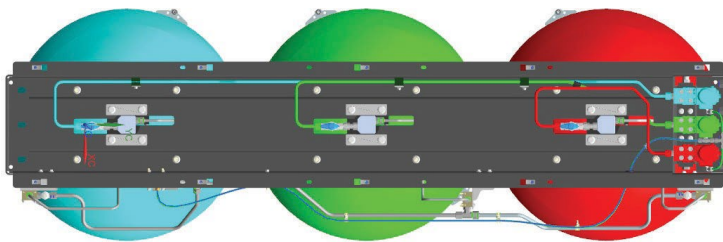

VALVE END OF CROSSMEMBER

RIGHT CENTER LEFT

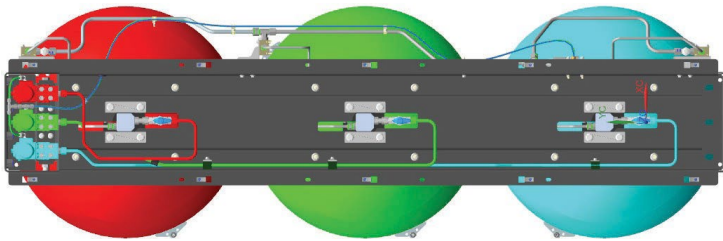

VALVE END OF CROSSMEMBER

TECHNICAL SERVICE BULLETIN

PRD Inlet Pipe Clearance Inspection

IMPORTANT: Visually inspect roof panels and verify they are in good condition. Make sure they are flat and have not been damaged. Pay particular attention around the openings for the PRD discharge pipe. Damaged roof panels may result in contact between the roof panel and a properly adjusted PRD assembly.

Repair or replace any damaged roof panels that may affect this clearance measurement prior to this inspection.

To verify PRD installed height is correct, the PRD inlet pipe to roof panel clearance needs to be measured, there must be a minimum of .125" (3.2mm) between the PRD inlet pipe and the roof panel.

1. Measure the clearance between the RH PRD inlet pipe and the roof panel as shown.

Direct measurement is not practical, a 0.125" diameter rod or drill bit may be used for measurement.

2. Measure the clearance between the LH PRD inlet pipe and the roof panel.

Note: At the time of publication of this bulletin, no LH or center PRD inlet pipes have been found that contact the roof panel.

3. Repeat steps 1 and 2 for every row in the trailer.
4. Identify and note the location of any PRD inlet pipes that do not have the minimum clearance.
5. Where any PRD inlet pipes are found too close to the roof panels, replace the PRD mounting bracket following the procedure in this bulletin.



TECHNICAL SERVICE BULLETIN

PRD Bracket R&R

This procedure is showing R&R of the RH PRD mounting bracket, replacement of the center and LH PRD mounting brackets are similar.

1. Remove and retain the fasteners securing the roof panel over the PRD inlet pipe that is out of tolerance.

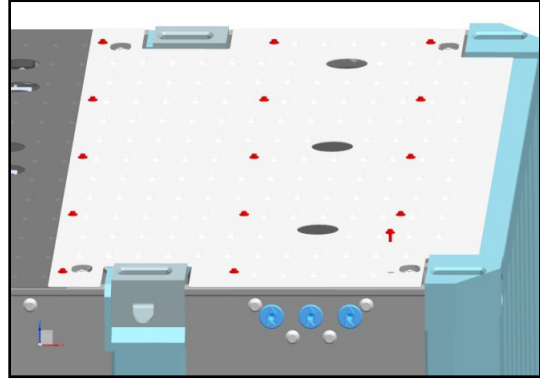

2. Mark the roof panel to indicate its position on the trailer. Remove and retain the roof panel.

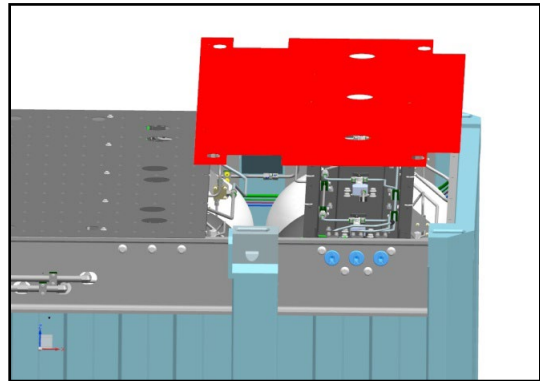

3. Where any PRD inlet pipe was found to be rubbing on the roof panel, inspect the pipe for any signs of damage or wear.

Measure and record the diameter of a straight, undamaged section of pipe away from any bends (A).

Then measure the diameter of the pipe where rubbing has occurred (B).

If the measured pipe wear is greater than or equal to 0.010", replace the PRD inlet pipe. Refer to *PRD Inlet Pipe Replacement* in this document.

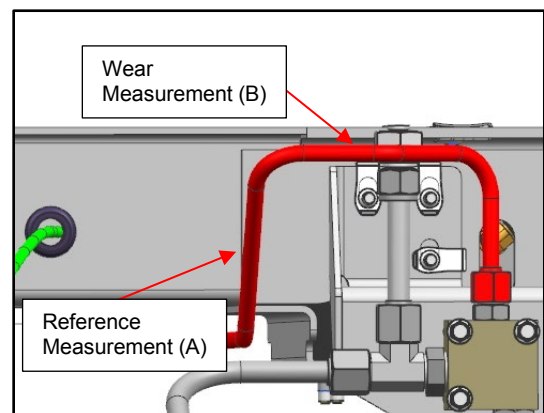

TECHNICAL SERVICE BULLETIN**PRD Bracket R&R (cont.)**

4. Remove and retain the three bolts and nuts securing the PRD block to the mounting bracket.

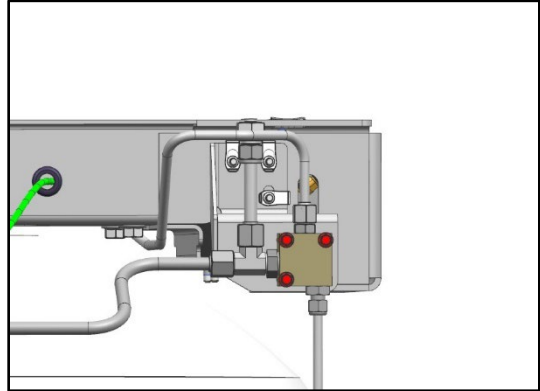

5. Using a crow foot wrench, remove and retain the three mounting bolts securing PRD bracket to cylinder crossmember.
6. Remove the PRD bracket taking care not to move the PRD assembly any more than needed to facilitate bracket removal.

Remove and retain the U-nuts, discard the bracket.

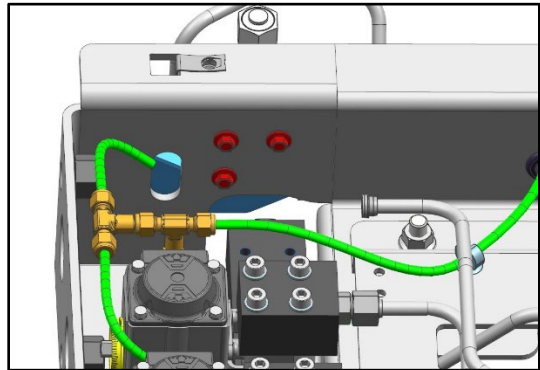

7. Install U-nuts on the new PRD bracket.

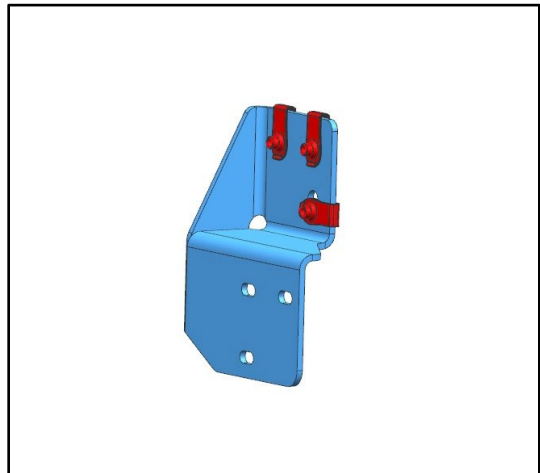

TECHNICAL SERVICE BULLETIN
PRD Bracket R&R (cont.)

8. Place the PRD bracket in position taking care not to move the PRD assembly any more than needed to facilitate bracket installation.

Align bracket with mounting holes in crossmember and install bolts finger tight.

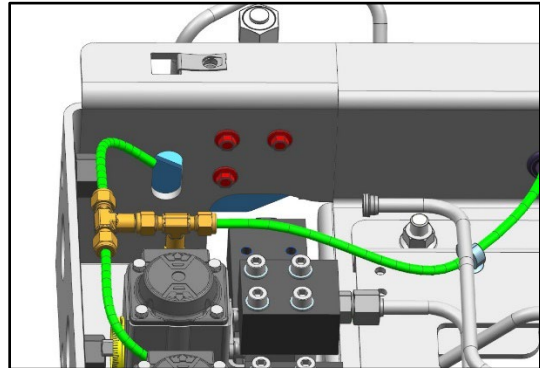

9. Align the PRD block to mounting holes in bracket, install bolts and nuts snug. Take care not to move the PRD assembly any more than needed to facilitate installation.

Using a backup wrench, tighten the PRD to bracket bolts.

Torque to 10 lb. ft (14 Nm).

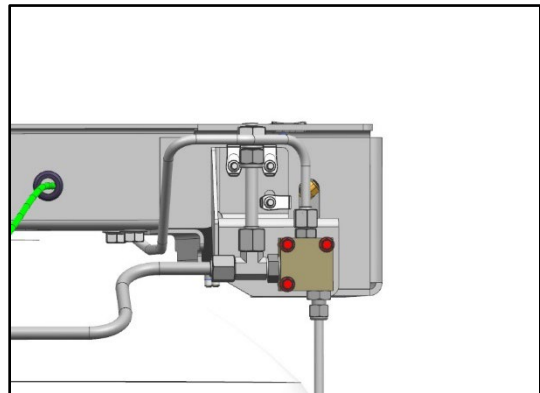

10. Adjust bracket so the PRD supply pipe is between 0.125"- 0.250" (3.2mm-6.4mm) below top edge of cylinder crossmember.

11. While maintaining correct position, tighten bracket to crossmember bolts snug so bracket does not move.

12. Verify there is still 0.125"- 0.250" (3.2mm-6.4mm) clearance.

NOTE: The PRD supply pipe may not be parallel to the top of the cross member, adjust the bracket height based on the pipe height at the closest point.

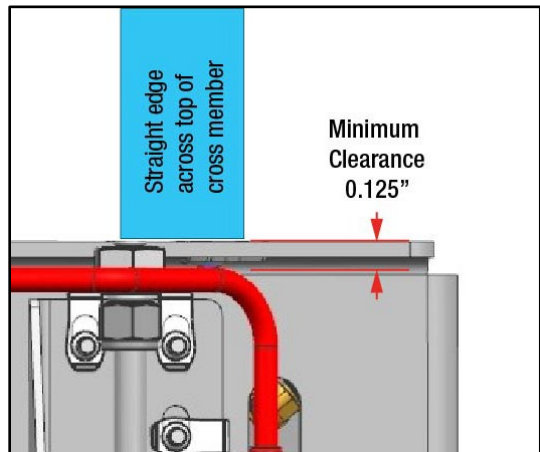

TECHNICAL SERVICE BULLETIN**PRD Bracket R&R (cont.)**

13. Using a crow foot wrench, tighten the bracket to crossmember bolts.

Torque to 9 lb. ft (12 Nm).

14. Before installing the roof panel, verify the clearance of the other two PRD supply pipes.

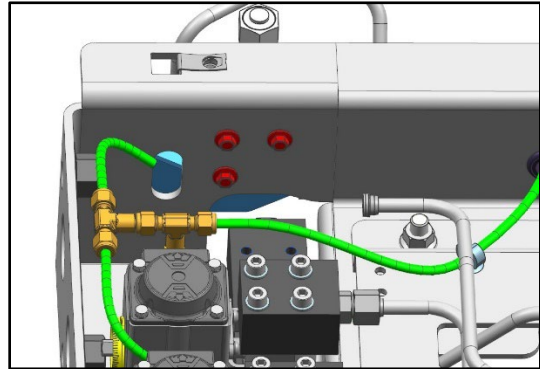

15. Locate the roof panel that was marked during removal for the position being installed. Place the roof panel in the position and align as needed.

IMPORTANT: Use care when positioning the panels, when sliding the panels across the cross members, the edge of the roof panel can catch and knock off the U-Nuts.

Where panels overlap, the forward panel should always be on top of the panel to the rear.

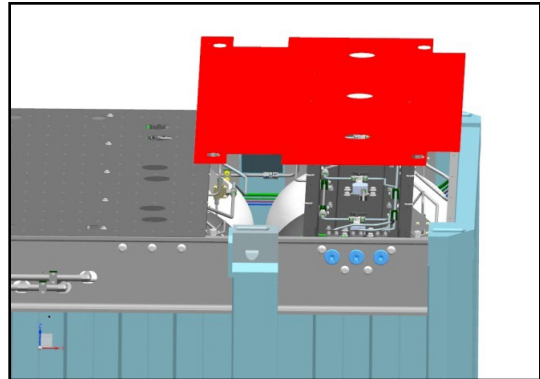

16. Loose fit all the roof panel fasteners; be sure to replace any fasteners that may have been missing prior to disassembly.

Tighten fasteners to 22 lb. ft (30 Nm.)

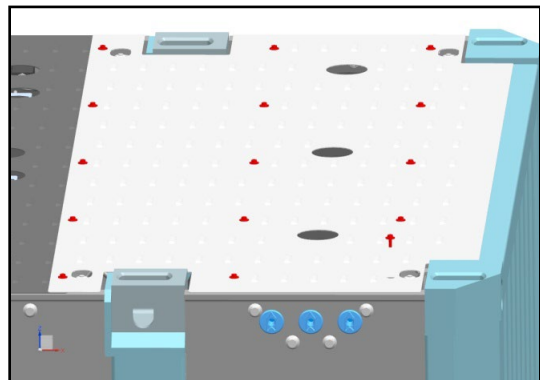

TECHNICAL SERVICE BULLETIN

PRD Supply Pipe Replacement

⚠ DANGER

The PRD assembly and PRD inlet pipes are always under cylinder pressure. Closing the cylinder manual valve(s) will not shut off pressure to the PRD assembly or PRD inlet pipes. Verify all pressure is completely vented from any cylinder or PRD inlet pipe(s) before proceeding with disassembly. Failure to properly vent the cylinder being serviced will result in death or serious injury.

Verify cylinder(s) requiring PRD inlet pipe replacement are at zero psi. These instructions are for right hand PRD inlet pipe replacement, middle and left side inlet pipe replacement is similar.

Each pipe on the trailer has a label that identifies the pipe assembly with its part number. Please reference this part number when requesting replacement pipes.

RH Removal

1. Close the cylinder manual shut off valve for the right-hand cylinder.

Valve at right shown in OPEN position. Oasis valve shown, others will be similar.

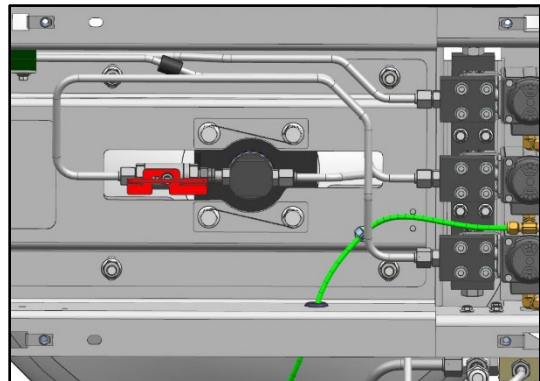

2. Using a backup wrench, disconnect the PRD inlet pipe from the tank head adapter fitting.

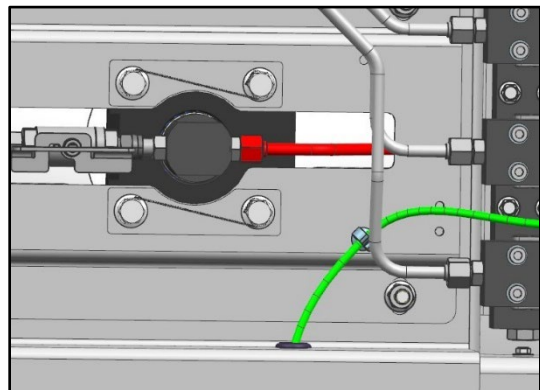

TECHNICAL SERVICE BULLETIN

PRD Supply Pipe Replacement (cont.)

Removal (cont.)

3. On the PRD vent pipe, make note of the distance from cylinder to pipe. This will be used for installation.
4. Using a backup wrench, disconnect the vent pipe from the right-side PRD block and middle TEE fitting.

Remove and discard O-rings on each fitting.

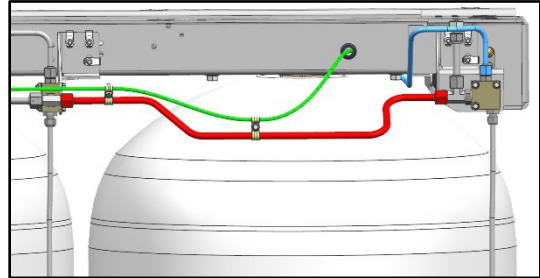

5. Leave the green pneumatic line attached to vent pipe and let hang while removing PRD pipe.

Lubricate and install new O-rings on all disturbed fittings.

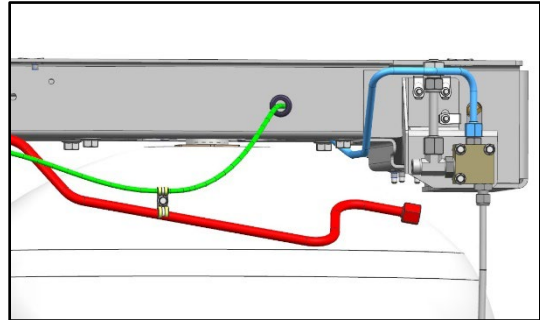

6. Using a backup wrench, disconnect the PRD inlet pipe from the PRD assembly.
7. Remove and discard the PRD inlet pipe.
8. Remove and discard O-rings from tank head and PRD block adapter fittings.

Lubricate and install new O-rings on all disturbed fittings.

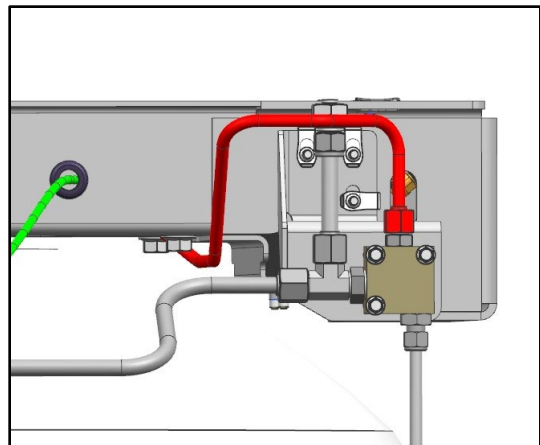

TECHNICAL SERVICE BULLETIN**PRD Supply Pipe Replacement (cont.)**

RH Installation

1. Install the PRD inlet pipe in the proper orientation and install tube nuts finger tight.

Using a backup wrench, tighten tube nuts.

Torque to 31 lb. ft (42 Nm).

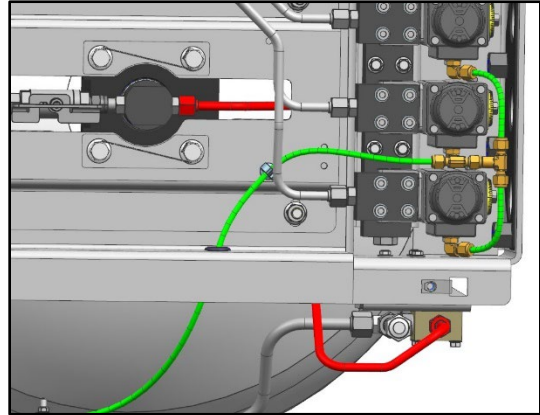

2. Position PRD vent pipe in place maintaining the previously noted distance to cylinder and tighten tube nuts finger tight.

While maintaining correct distance, use a backup wrench and tighten tube nuts.

Torque to 58 lb. ft (78 Nm).

