

March 2023
SF662 A

Subject: TomTom Android Black Box Update

Models Affected: Specific Model Year 2020-2022 Freightliner Cascadia Vehicles, manufactured January 16, 2019, through November 2, 2021.

General Information

Daimler Truck North America LLC (DTNA), on behalf of its Freightliner Trucks Division, is initiating Field Service Campaign SF662 to modify the vehicles mentioned above.

On certain vehicles, the TomTom Android Black Box was not installed due to pending certification, or if installed, the navigation feature may not operate.

An updated electronic control unit (ECU) will be installed on each vehicle.

There are approximately 346 vehicles involved in this campaign.

Additional Repairs

Dealers must complete all outstanding Recall and Field Service campaigns prior to the sale or delivery of a vehicle. A Dealer will be liable for any progressive damage that results from its failure to complete campaigns before sale or delivery of a vehicle.

Owners may be liable for any progressive damage that results from failure to complete campaigns within a reasonable time after receiving notification.

Please contact Warranty Campaigns for consideration of additional charges prior to performing the repair.

Work Instructions

Please refer to the attached work instructions. Prior to performing the campaign, check the vehicle for a completion sticker (Form WAR261).

Replacement Parts

Replacement parts are now available and can be obtained by ordering the parts listed below from your facing Parts Distribution Center (PDC).

If our records show your dealership has ordered any vehicle(s) involved in campaign number SF662, a list of the customers and vehicle identification numbers will be available using the OWL app located on the DTNA Portal. Please refer to this list when ordering parts for this campaign.

Table 1 - Replacement Parts for SF662

Campaign Number	Part Number	Part Description	Qty.
SF662 A	A 008 820 15 26	ECU-ASSY, BKT, APP PLTFRM HO USA	1
	A23-14454-086	CABLE-HSD, MINI-B, ASSY, 2184MM	1
	A66-08143-000	HARN-ANDR_BB, OL, DASH, PWR, LHD	1
	23-10897-704	SCREW-TPG, PHIT AB, 6	2
	23-12537-010	FUSE-MINI BLADE, 10A, RED	1
	WAR261	BLANK COMPLETION STICKER	1

Table 1

March 2023
SF662 A

Removed Parts

U.S. and Canadian Dealers, please follow Warranty Failed Parts Tracking shipping instructions for the disposition of all removed parts. Export distributors, please destroy removed parts unless otherwise advised.

Labor Allowance

Table 2 - Labor Allowance

Use 996-F147A: If there is no existing TomTom, and no existing wiring harness.

Use 996-F147B: If TomTom is installed, replaced, or reinstalled, and the wiring harness is already present.

Campaign Number	Procedure	Time Allowed (hours)	SRT Code	Corrective Action
SF662 A	Install <u>Module & Harness</u>	2.1	996-F147A	12-Repair Recall/Campaign
	Install or Reinstall <u>Module Only</u>	1.1	996-F147B	12-Repair Recall/Campaign

Table 2

IMPORTANT - Before Beginning Work:

- Check OWL to ensure the vehicle is involved and the campaign has not previously been completed.
- Check the vehicle for a completion sticker.

IMPORTANT - After Repair is Complete:

- Attach a gray completion sticker (Form WAR261) to the base completion label (Form WAR259). If the vehicle does not already have a base completion label, clean a spot on the appropriate location of the vehicle, and attach a base completion label, prior to installing the completion sticker.

Claims for Credit

You will be reimbursed for your parts, labor, and handling (landed cost for Export Distributors) by submitting a claim. Please reference the following information in OWL:

- All claims must be submitted within 30 days of the repair date.
- Claim type is **Field Service Campaign**.
- In the Campaign field, enter the campaign number and population/group code (**SF662-A**).
- In the Primary Failed Part field, enter **25-SF662-000**.
- In the Parts section, enter the appropriate part number(s) as shown in the Replacement Parts Table.
- In the Labor section, enter the appropriate SRT from the Labor Allowance Table. Administrative time will be included automatically as SRT 939-6010A for 0.3 hours.
- The VMRS Component Code is **F99-999-005**, and the Cause Code is **A1 - Campaign**.
- This Field Service Campaign will **terminate on March 31, 2024**. Dealers will be notified of any changes to the termination date via an Important Campaign Information Letter (ICI) posted on the DTNA Portal.

Excess Inventory: U.S. and Canadian dealers, following the conclusion of the campaign, within 90 days from the termination date, excess inventory in resalable condition may be returned to the appropriate PDC. U.S. dealers, submit a PAR to request return to the Memphis PDC. Canadian dealers, return inventory to your facing PDC. Export Distributors, excess inventory is not returnable.

For Support: Contact the Warranty Campaigns Department using the WSC (Warranty Support Center) link on the DTNA Portal, or call the Customer Assistance Center at (800) 385-4357. Export distributors, submit a WSC ticket or contact your International Service Manager.

March 2023
SF662

Copy of Notice to Owners

Subject: TomTom Android Black Box Update

Daimler Truck North America LLC (DTNA), on behalf of its Freightliner Trucks division, is initiating Field Service Campaign SF662 to modify specific model years 2020-2022 Freightliner Cascadia vehicles, manufactured January 16, 2019, through November 2, 2021.

On certain vehicles, the TomTom Android Black Box was not installed due to pending certification, or if installed, the navigation feature may not operate.

An updated electronic control unit (ECU) will be installed on each vehicle.

Please contact an authorized DTNA dealer to arrange to have the campaign performed and to ensure that parts are available at the dealership. The repair will take approximately two hours and will be performed free of charge. To locate an authorized dealer, search online at NorthAmerica.DaimlerTruck.com/Contact-Us/. Scroll down to "Locate a Dealer," and select the appropriate brand.

This Field Service Campaign will **terminate on March 31, 2024**. Please make sure the campaign is completed prior to this date. Work completed after this date will be done at the customer's expense.

As stated in the terms of your express limited warranty, DTNA will not pay for any damage caused by failure to properly maintain your vehicle. DTNA considers the work necessary under this campaign to be proper maintenance and will, therefore, not pay for any damage to your vehicle caused by your failure to have the repairs that are the subject of this campaign performed in a reasonable time.

Contact the Warranty Campaigns Department at (800) 547-0712, e-mail address DTNA.Warranty.Campaigns@Daimlertruck.com, or the Customer Assistance Center at (800) 385-4357, if you have any questions or need additional information.

WARRANTY CAMPAIGNS DEPARTMENT

Enclosure

March 2023
SF662 A

Work Instructions

Subject: TomTom Android Black Box Update

Models Affected: Specific model years 2020-2022 Freightliner Cascadia vehicles, manufactured January 16, 2019, through November 2, 2021.

TomTom Installation

The following is an overview of the work instructions for this campaign.

- Inspection of the existing TomTom (if present) for the latest part.
 - Installation of the TomTom navigation ECU behind the driver's flat panel display.
 - Installation of the USB cable between the TomTom ECU and the multimedia box (MMB) in the dash B-panel (if cable is not already present).
 - Installation of the wiring harness for the TomTom ECU – splices into the VPDM and Connect 5 (ICC5) wiring in the Electrical Bay (if harness is not already present at the TomTom).
1. Check the base label (Form WAR259) for a completion sticker for SF662 (Form WAR261) indicating this work has been completed. The base label is usually located on the passenger-side door, about 12 inches (30 cm) below the door latch. If a completion sticker is present, no work is needed. If a completion sticker is not present, proceed to the next step.
 2. Park the vehicle on a level surface, shut down the engine, and set the parking brake. Chock the tires.
 3. Disconnect the negative cable(s) from the main batteries.
 4. Disconnect the negative cable(s) from the auxiliary batteries, if so equipped.
 5. For substeps 5.1 through 5.8, see **Section 54.18** and **Section 60.06** of the *New Cascadia Workshop Manual* for more information.

March 2023
SF662 A

5.1 Remove the instrument cluster screen. See [Fig. 1](#).

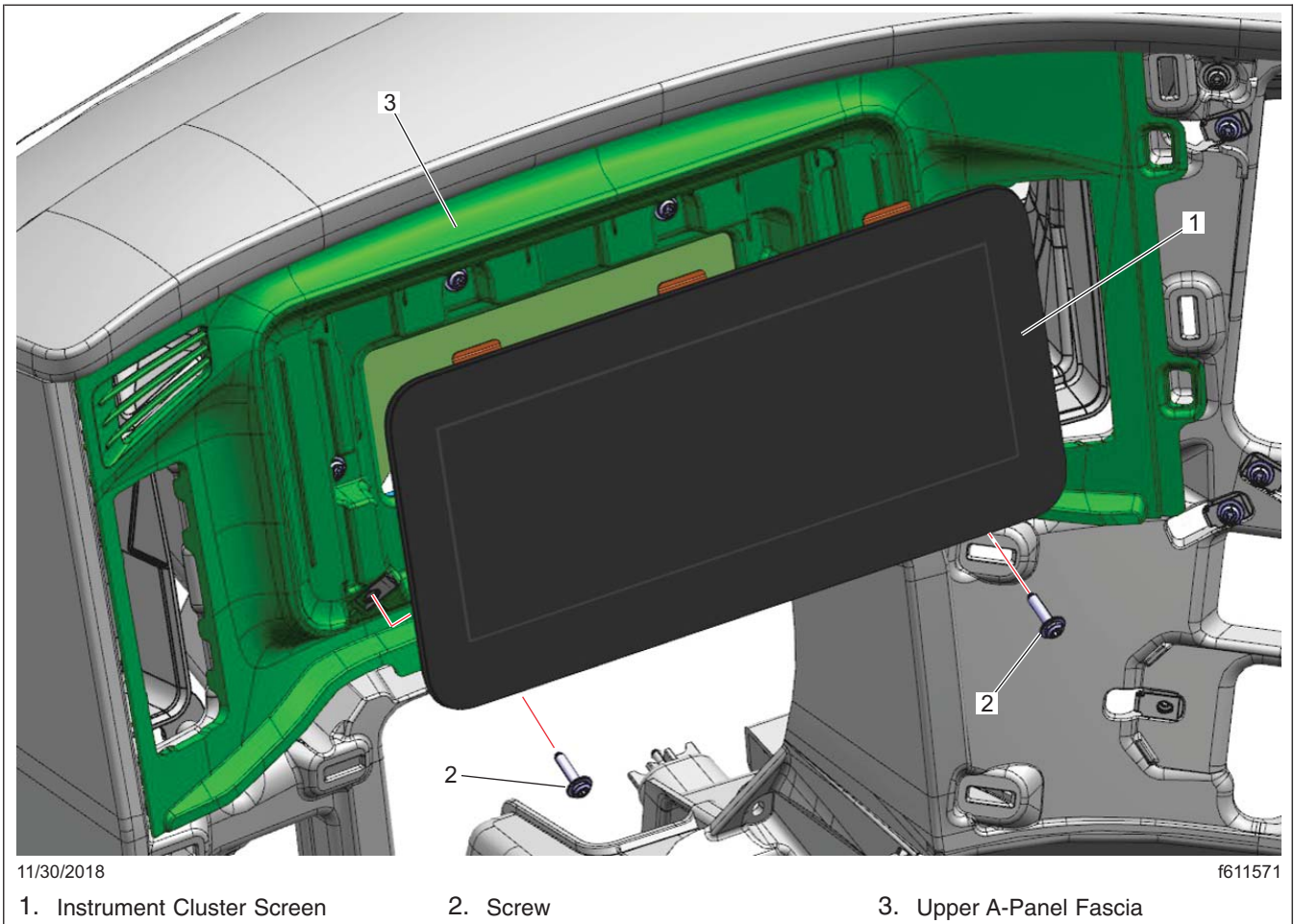

Fig. 1, Instrument Cluster Screen Removal

March 2023
SF662 A

5.2 Remove the head unit screen. See [Fig. 2](#).

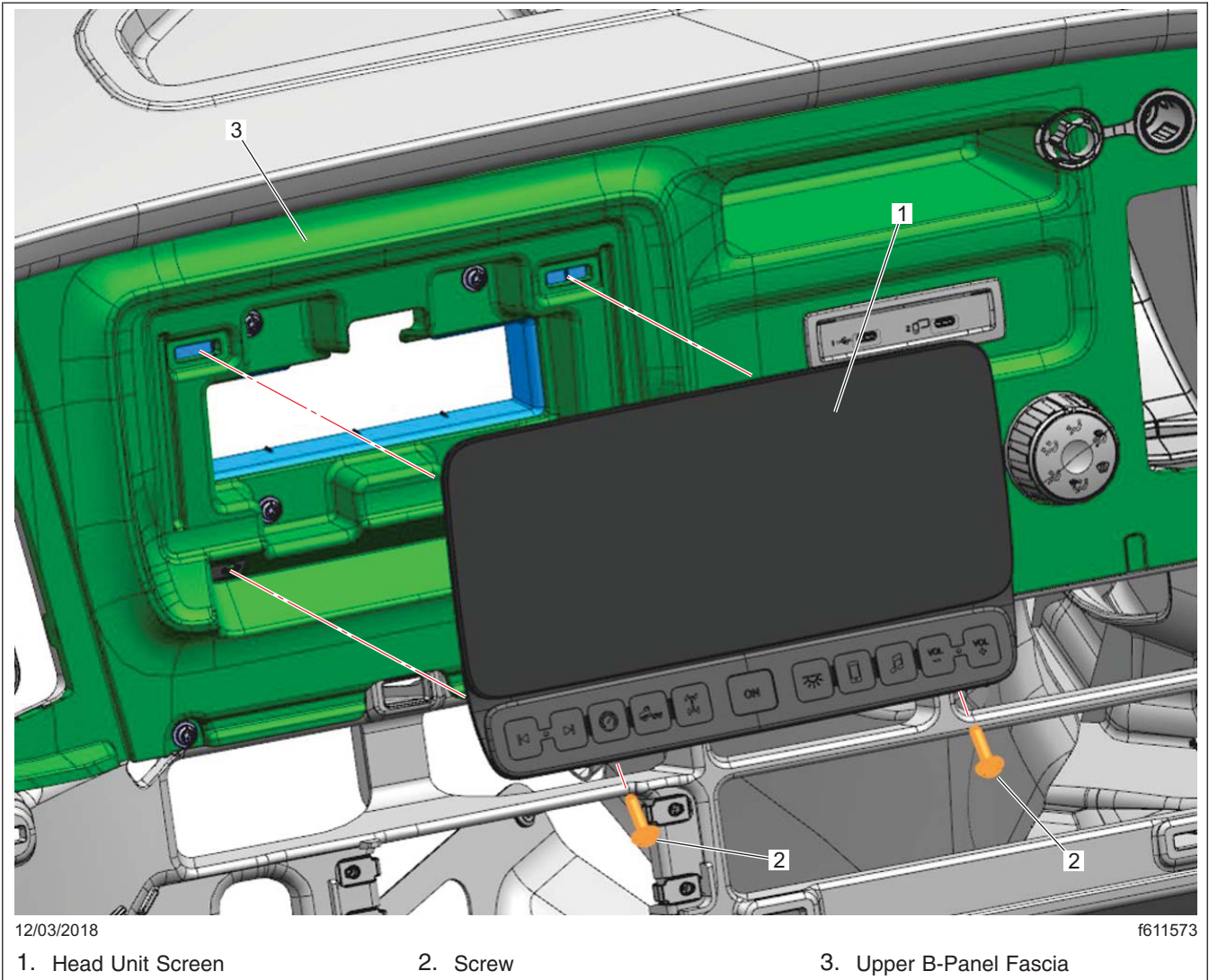

Fig. 2, Head Unit Screen Removal

March 2023
SF662 A

5.3 Remove the lower B-panel fascia (switch panel), and disconnect the wiring as needed. See [Fig. 3](#).

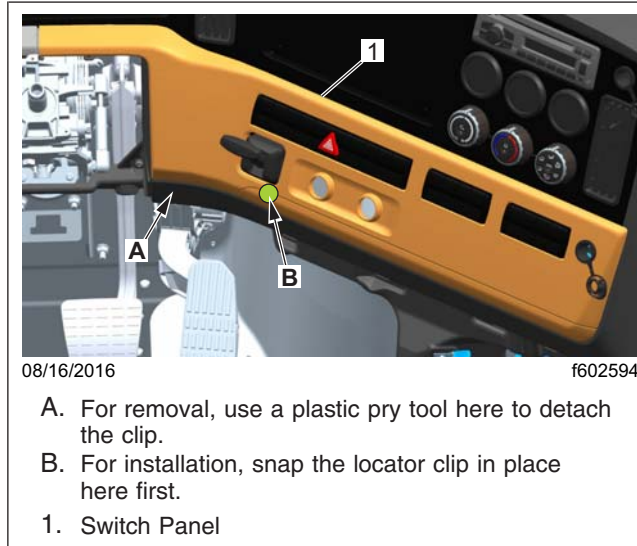

Fig. 3, Lower B-Panel Fascia Removal

5.4 Remove the lower A-panel fascia. See [Fig. 4](#).

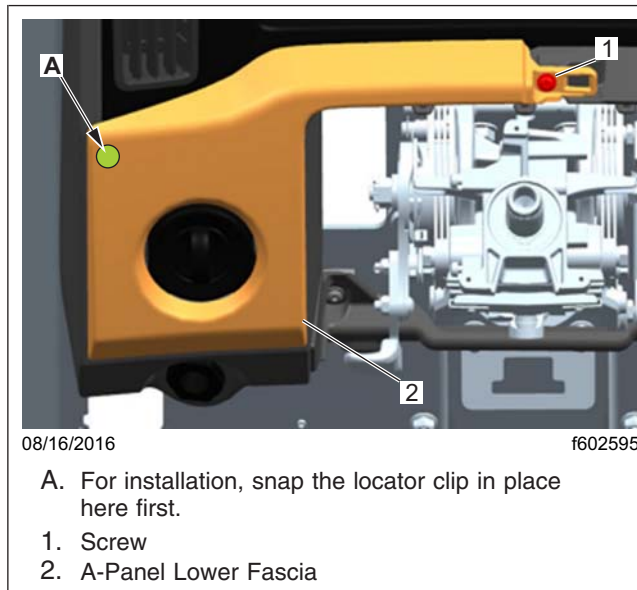

Fig. 4, Lower A-Panel Fascia Removal

March 2023
SF662 A

5.5 Remove the upper B-panel fascia, and disconnect the wiring as needed. See [Fig. 5](#).

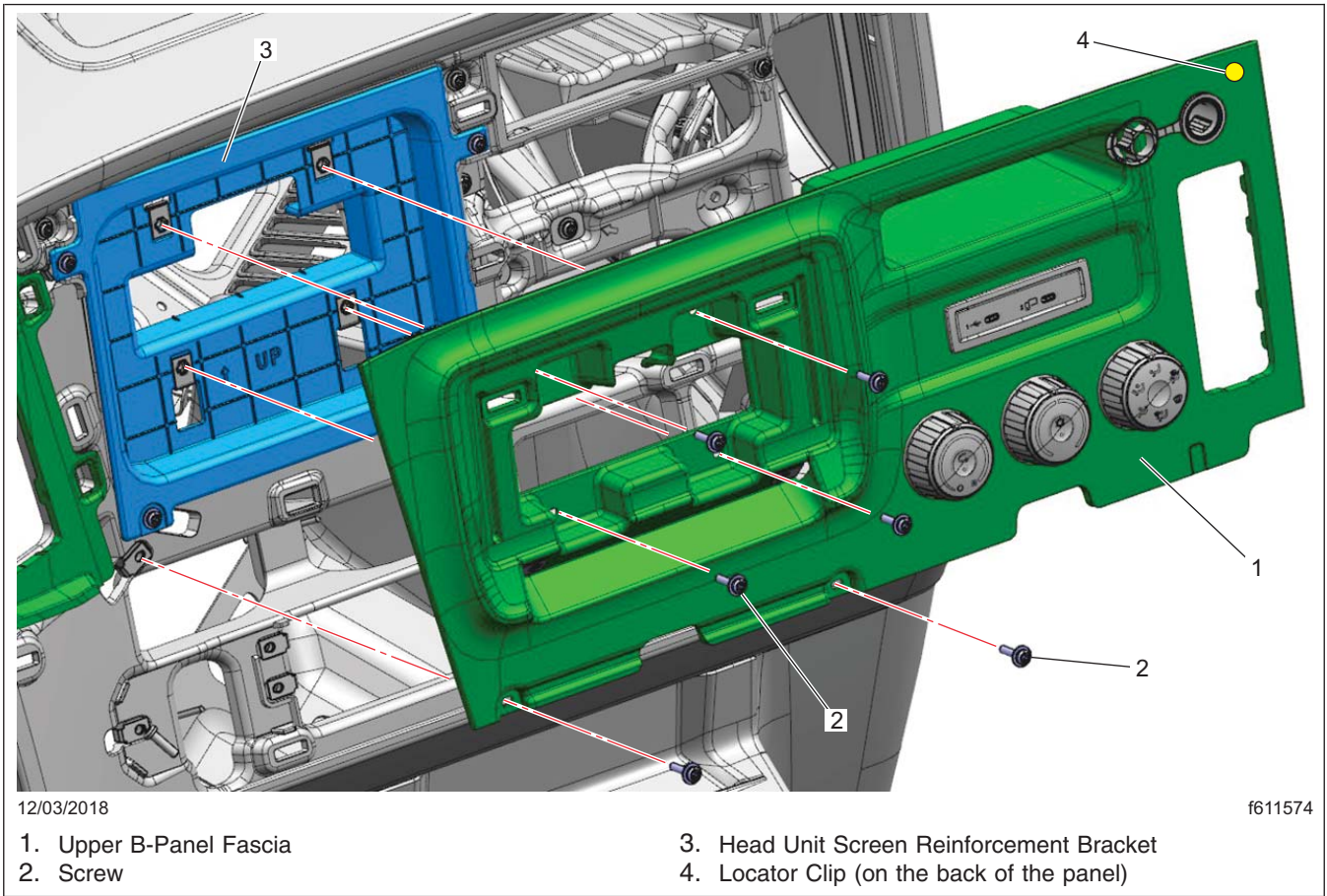

Fig. 5, Upper B-Panel Fascia Removal

March 2023
SF662 A

5.6 Remove the upper A-panel fascia. See **Fig. 6**.

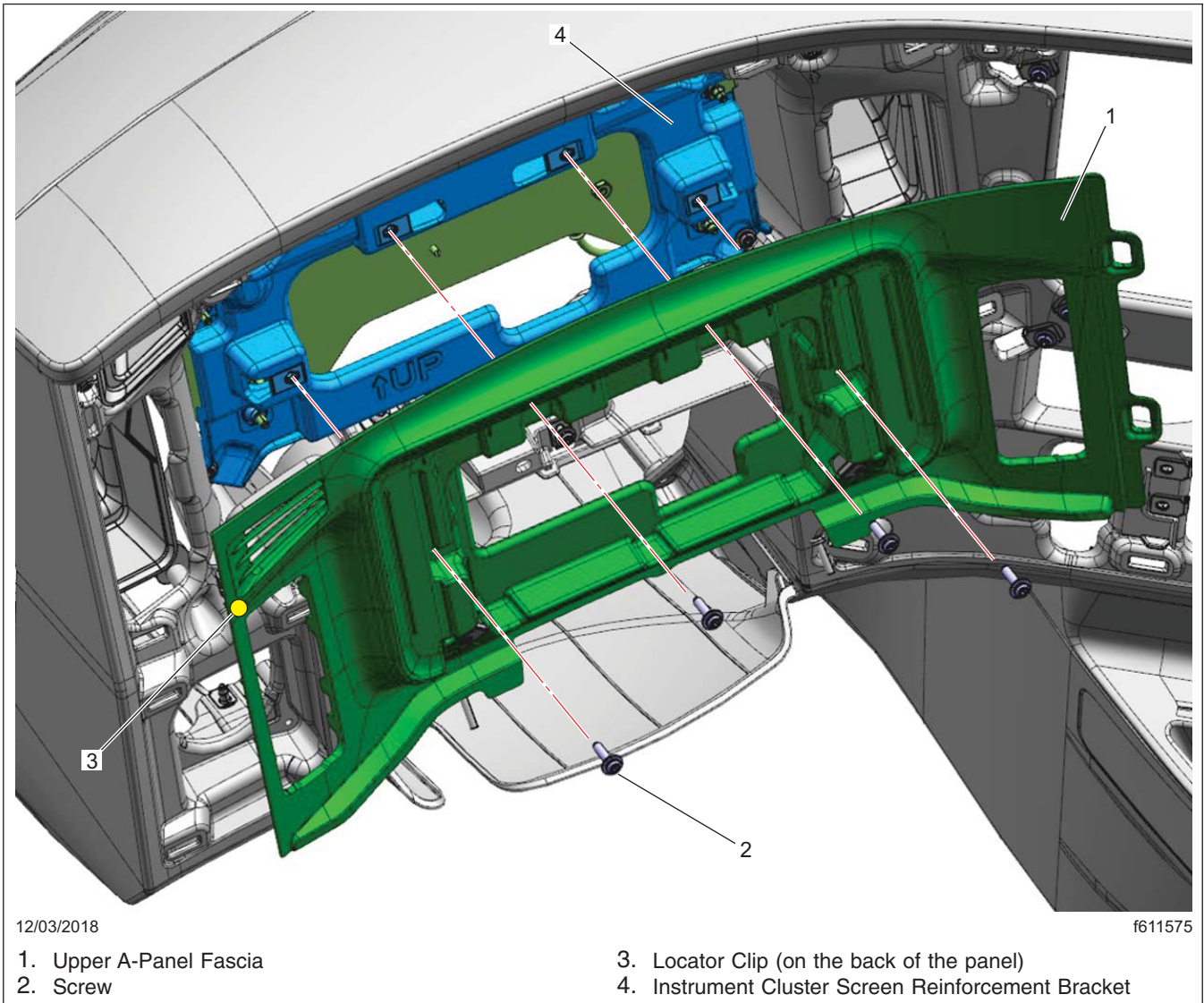

Fig. 6, Upper A-Panel Fascia Removal

March 2023
SF662 A

- 5.7 Remove the instrument cluster screen reinforcement bracket. Disconnect the wiring from the back side as needed. See [Fig. 7](#).

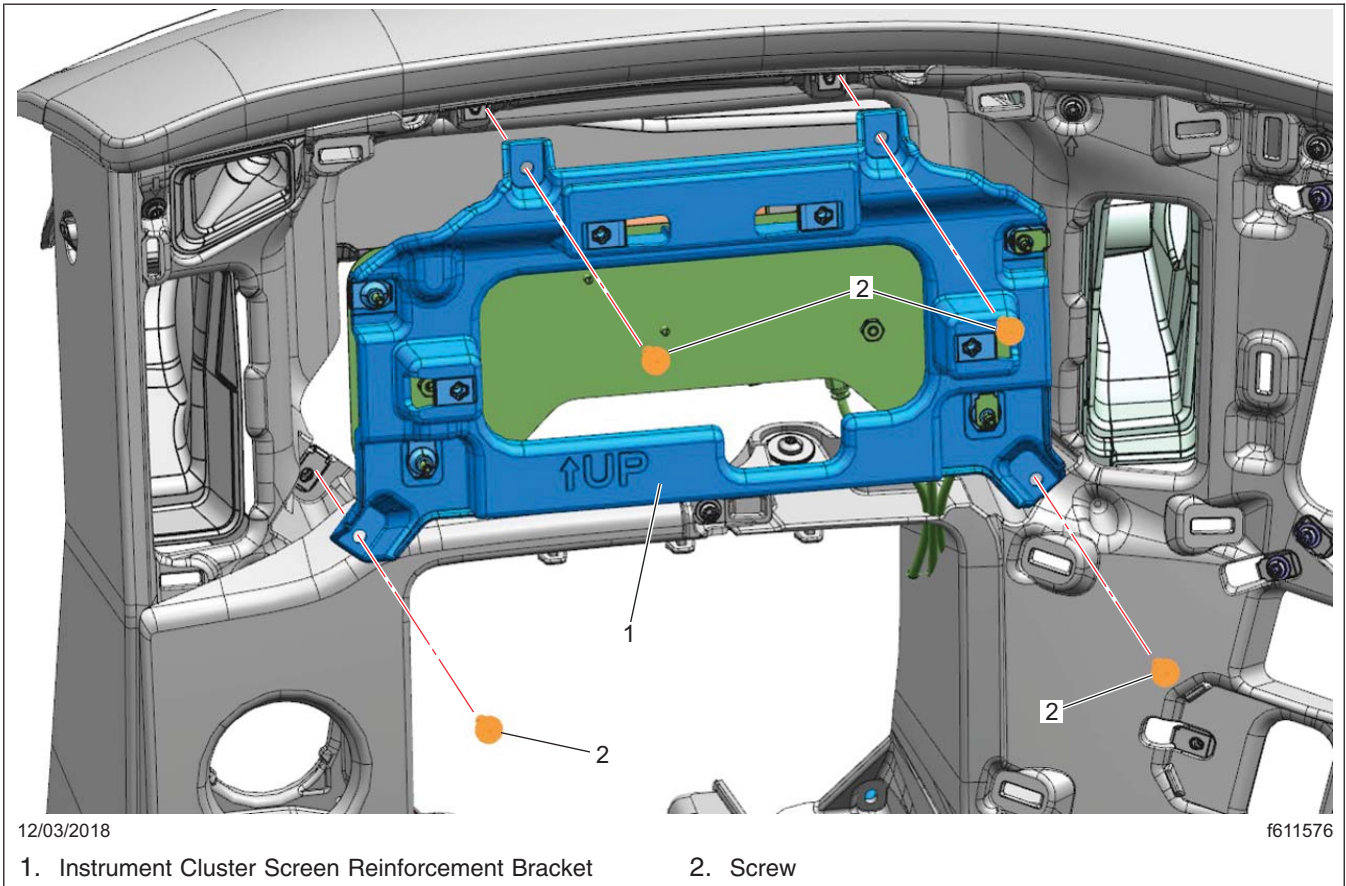

Fig. 7, Instrument Cluster Screen Reinforcement Bracket Removal

- 5.8 Remove the electrical bay cover. See [Fig. 8](#).



Fig. 8, Electrical Bay Cover Location

March 2023
SF662 A

6. Check if a TomTom module is already installed on the back side of the instrument cluster screen reinforcement. See [Fig. 11](#).

Is a TomTom module already installed?

YES → Go to step 7.

NO → Go to step 8.

NOTE: If a TomTom module is already installed, it is assumed that the associated wiring is also present. If not, go to step 9 instead of step 17 after completing step 7.

7. Remove the TomTom from the bracket, and check the part number on the label on the bottom side. See [Fig. 9](#).

Is the part number **A 008 820 15 26**?

YES → Install the existing TomTom on the bracket, then go to step 17 (step 9 if wiring not present.)

NO → Install the new TomTom, then go to step 17 (step 9 if wiring not present.)



Fig. 9, TomTom Part Number Identification

March 2023
SF662 A

8. Install the TomTom module on the back side of the instrument cluster screen reinforcement bracket.
 - 8.1 Align the TomTom bracket with the pre-drilled holes on the instrument cluster screen reinforcement bracket metal plate, then secure the bracket to the plate using the two screws. See [Fig. 10](#).

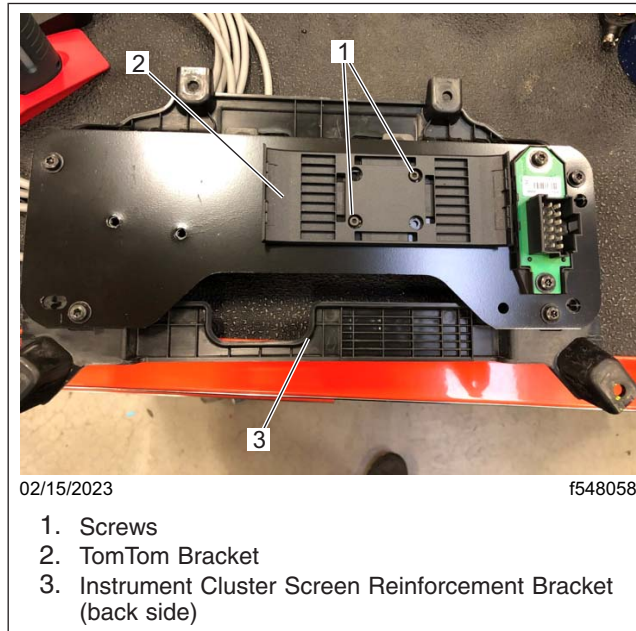

Fig. 10, TomTom Bracket Installation

- 8.2 Snap the TomTom module into the bracket as shown in [Fig. 11](#).



Fig. 11, TomTom Module Installation

March 2023
SF662 A

9. Route the USB cable from the TomTom module location to the multimedia box (MMB). See **Fig. 12** and **Fig. 13**. Ensure the cable ends are routed correctly, as shown in **Fig. 14**.



Fig. 12, Multimedia Box Location

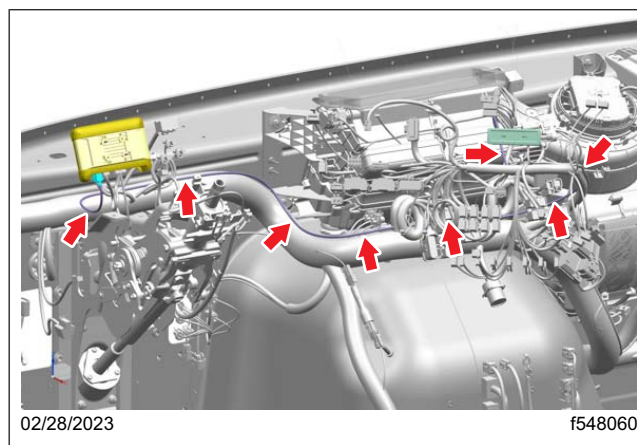

Fig. 13, USB Cable Routing Between TomTom and Multimedia Box

March 2023
SF662 A

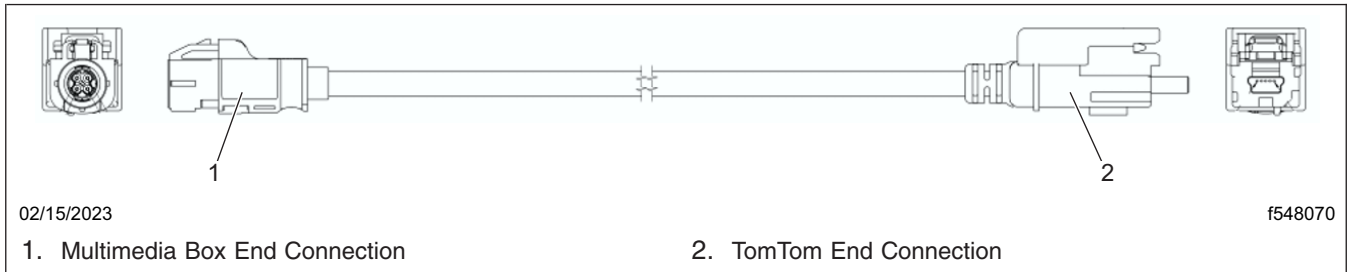

Fig. 14, USB Cable End Connections

10. Check if the 16-pin harness connector is present behind where the TomTom mounts.
Is the 16-pin harness connector present?
YES → Go to step 17.
NO → Go to step 11.
11. Install the TomTom harness.
 - 11.1 Route the harness from the TomTom location to the electrical bay along the main dash harness.
See Fig. 15 for the harness routing. Secure the harness to the main harness with zip ties as necessary.

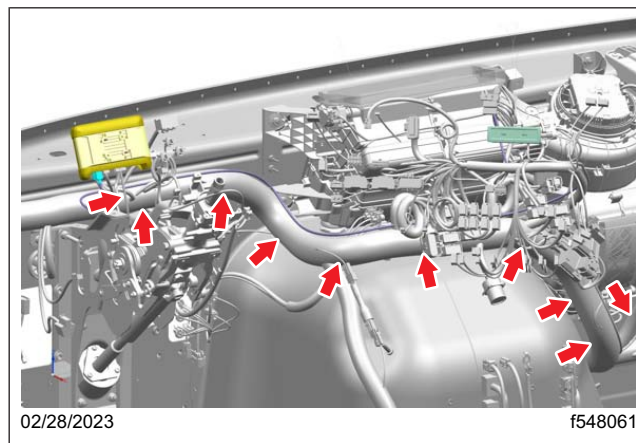

Fig. 15, Harness Routing

NOTE: It may be helpful to use a section of airline or some other method to help route and pull the harness behind the dash panels.

Leave enough slack at the TomTom location (6 to 8 inches) to be able to make the connection with the TomTom module.

March 2023
SF662 A

- 12. Access the electrical bay.
 - 12.1 Remove the right hand lower dash cover. See [Fig. 16](#).

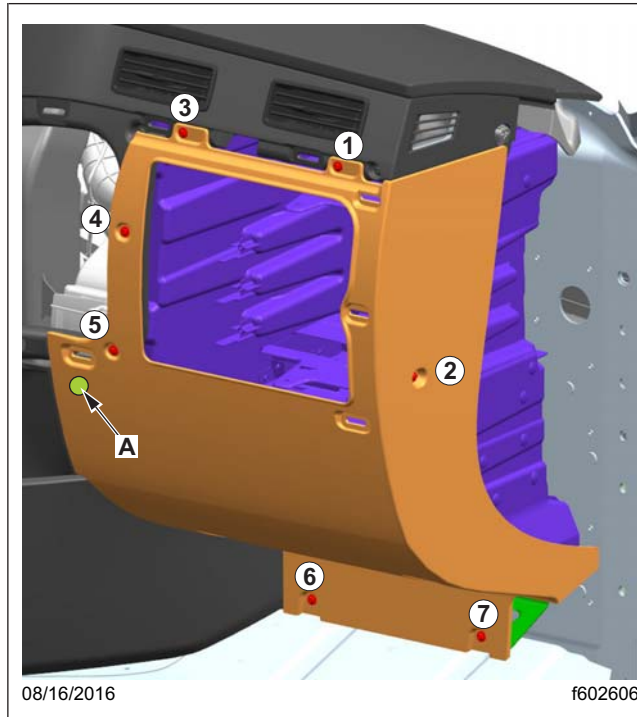

Fig. 16, Right Hand Lower Dash Cover Removal

- 12.2 Lower the VPDM to the floor. For instructions, see **Section 54.08.100** of the *New Cascadia Workshop Manual*.
- 13. Make harness connections.
 - 13.1 Route the harness along the main harness into the electrical bay.
 - 13.2 Route the two black wires (circuits 545H and GRD) toward the Connect 5 module X1 connector (white latch connector). See [Fig. 17](#).

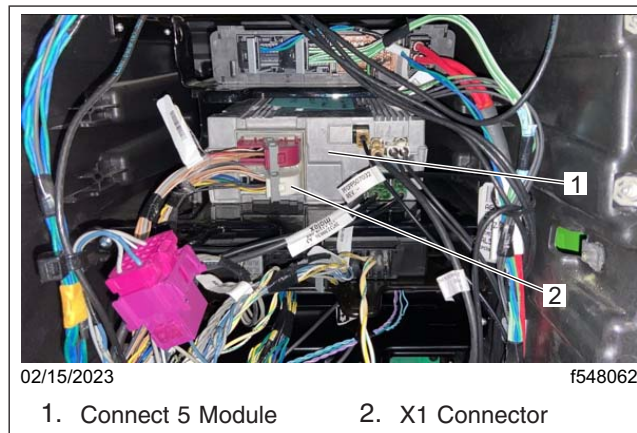

Fig. 17, Connect 5 and X1 Connector Location

March 2023
SF662 A

13.3 Route the green wire (circuit 433) along the harness leading to the VPDM connector J5. See [Fig. 18](#).

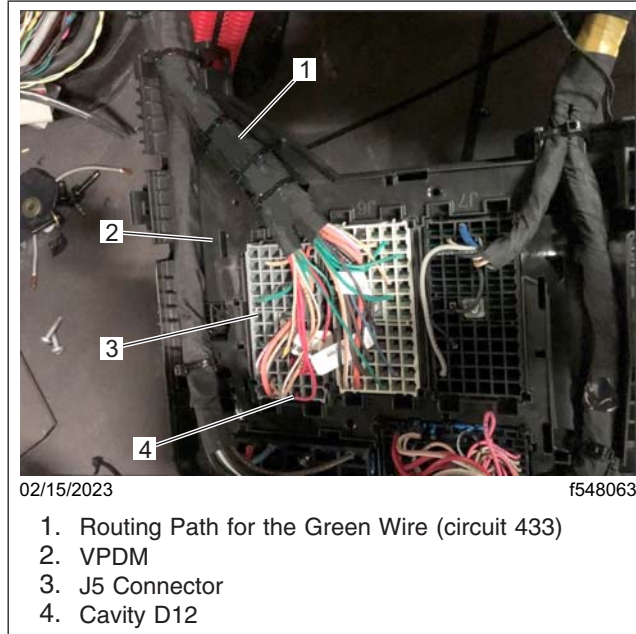

Fig. 18, VPDM J5 Connector

13.4 At the VPDM J5 connector, check if there is a red wire already populating pin J5/D12. See [Fig. 18](#).

Is there a red wire in J5/D12?

YES → Cut the terminal off the end of the green 433 circuit of the harness being installed, then splice that wire into the red wire in J5/D12 about 3 inches from the J5 connector. For splicing procedures, see [Section 54.00.100](#) of the *New Cascadia Workshop Manual*. See [Fig. 19](#).

NO → Install the terminal on the green 433 circuit into the J5/D12 cavity.

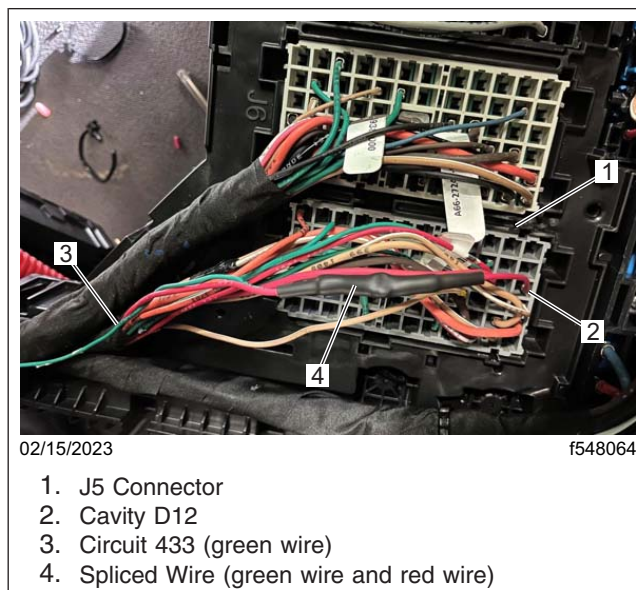

Fig. 19, Circuit 433 Splice Detail

March 2023
SF662 A

- 13.5 Secure the green 433 circuit to the harness bundle leading to the VPDM with zip ties as needed.
- 13.6 In the harness leading to the Connect 5 X1 connector (white latching connector), locate the circuits 545B and 545H as both have black wires. See [Fig. 20](#).



**Fig. 20, Locating Existing Circuits 545B and 545H
Connecting to Connect 5**

March 2023
SF662 A

13.7 About 6 inches from the Connect 5 X1 connector, splice the black GRD circuit of the harness being installed to the black 545B circuit leading to the Connect 5 X1 connector. See **Fig. 21**. For splicing procedures, see **Section 54.00.100** of the *New Cascadia Workshop Manual*. See **Fig. 22**.

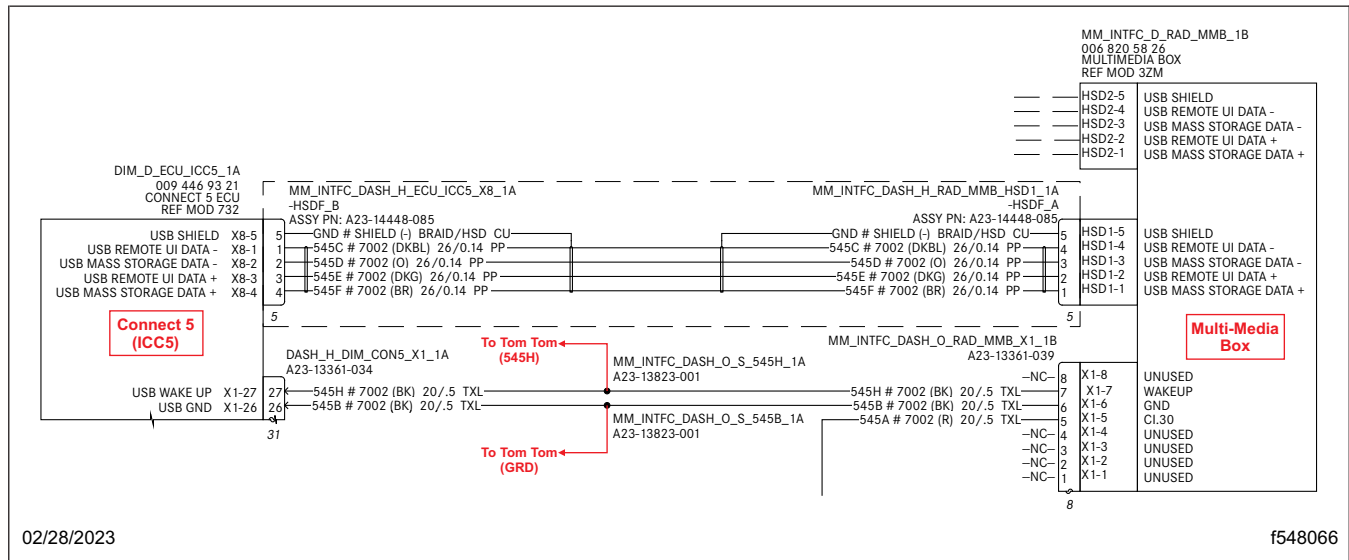

Fig. 21, Splicing Harness

March 2023
SF662 A

- 13.8 About 8 inches from the Connect 5 X1 connector, splice the black 545H circuit of the harness being installed to the black 545H circuit leading to the Connect 5 X1 connector. See [Fig. 21](#) and [Fig. 22](#).
- 13.9 Secure the spliced wires to the harness bundle as shown in [Fig. 22](#). Plug the X1 connector back into the Connect 5 ECU.

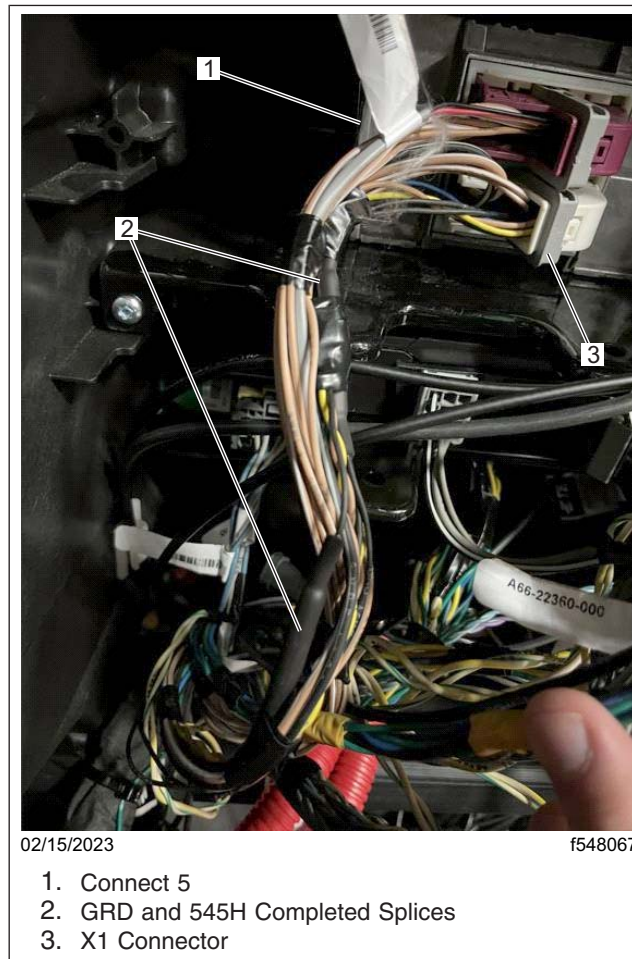

Fig. 22, Completion of Splicing

14. Install the VPDM. For instructions, see **Section 54.08.100** of the *New Cascadia Workshop Manual*.
15. Install the right hand lower dash cover. See [Fig. 16](#). For instructions, see **Section 60.06** of the *New Cascadia Workshop Manual*.
16. Remove the VPDM cover, check if 10A fuse F24 is present.

Is the fuse F24 present?

YES → Install the VPDM cover, then go to step 17.

NO → Install a 10A fuse in the fuse location F24, install the VPDM cover, then go to step 17.

March 2023
SF662 A

17. Plug the 16-pin connector and USB cable into the TomTom module. See [Fig. 23](#).

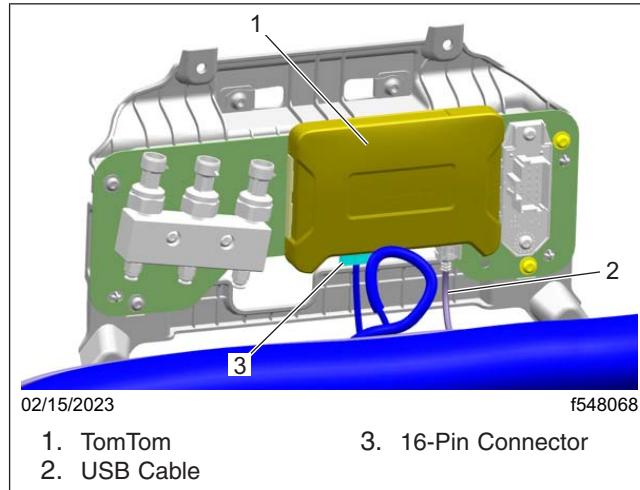

Fig. 23, Electrical Connections at the TomTom ECU

18. Install the instrument cluster screen reinforcement bracket with the TomTom module attached back on the dash. See [Fig. 7](#).
19. Plug the other end of the USB cable into the multimedia box. See [Fig. 24](#). This step is only necessary if there was no existing TomTom module.

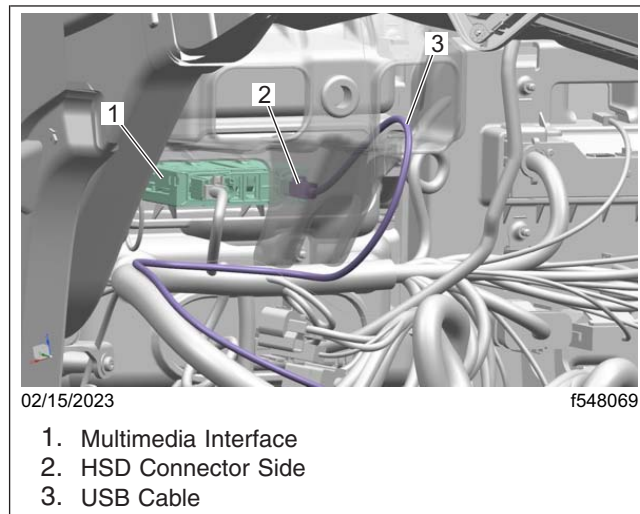

Fig. 24, USB Cable Connection at the Multimedia Box

March 2023
SF662 A

20. Install the dash panels.
21. Activate the TomTom navigation.
 - 21.1 Connect the vehicle to Diagnosticlink®.
 - 21.2 Turn the ignition key to the 'Run' position.
 - 21.3 Open Diagnosticlink.
 - 21.4 Go to the 'Program Device' tab, and make sure that the vehicle identification number (VIN) is correct. Select 'Download data from server.' See **Fig. 25**.

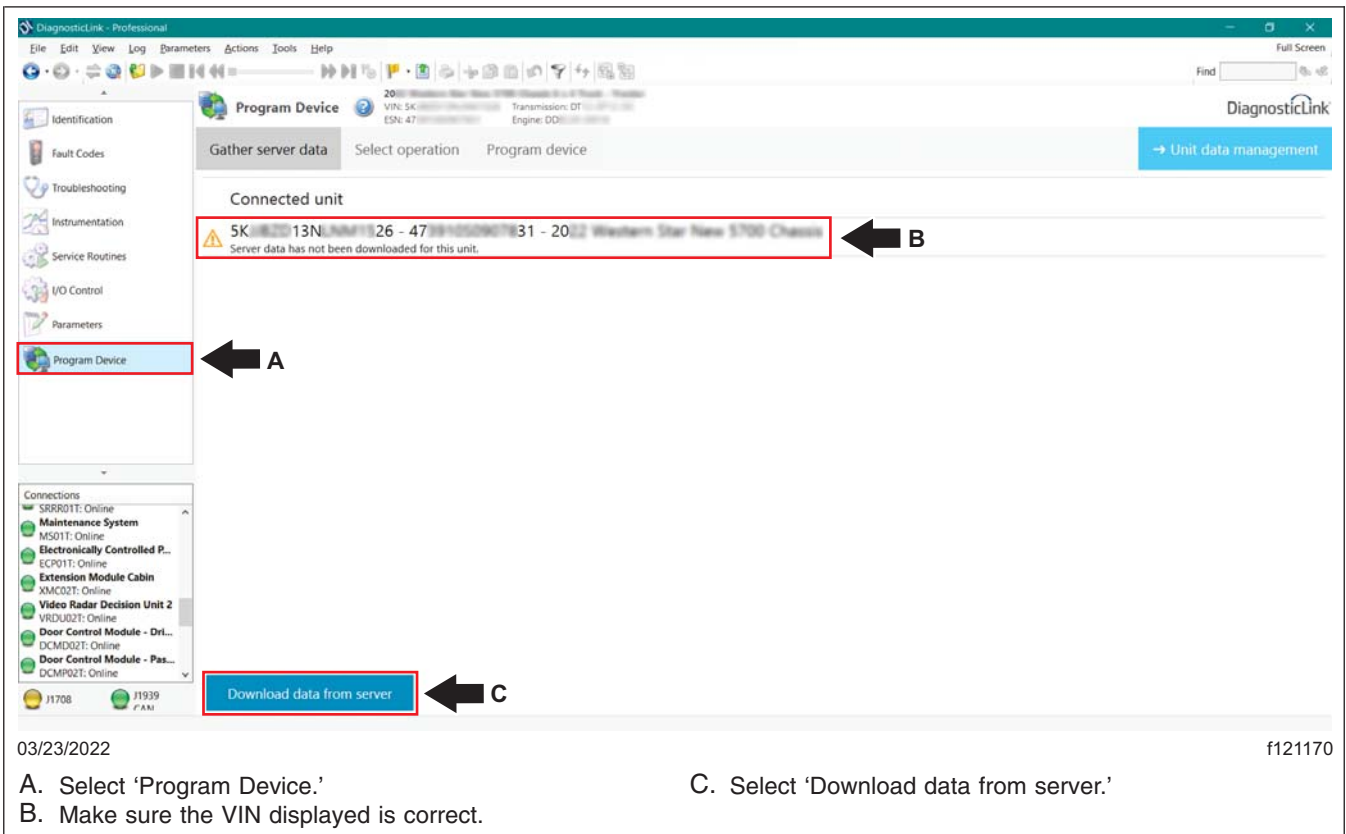

Fig. 25, Downloading Vehicle Data

March 2023
SF662 A

21.5 After the server data download is complete, go to the 'Parameters' tab, then go to the 'ICC501T Instrument Cluster 5' folder. Select the 'PID 0x40 Vehicle configuration parameters' folder and expand it by selecting the '+' to the left of it. Then select the 'PT_OnBoardNavi_AVL' fragment. See Fig. 26.

DiagnosticLink
File Edit View Log Parameters Actions Tools Help

2020 Freightliner New Cascadia 126 Sleeper Cab 6 x 4 Truck-Tractor
VIN: 1F...40 Engine: D... Transmission: D...

Parameters for APS301T, CGW04T, CTP01T, DCMD02T, DCMP02T, FNPAD01T, HVAC_F01T, ICC501T, MS01T, RDF02T, SRRR01T, SSAM02T, VRDU02T, XMC02T was not possible to verify their Last Serviced data. Click here to open the Program Device view to download data for this vehicle before attempting to make

Parameter	Value	Units	Minimum	Maximum
PT_TC_VolumeCorrFactor	100.0	%	87.5	112.5
PT_FL_FuelReserveHysteresis	14.0	%	0.0	100.0
PT_ABL_MinRangeCons	0.720	l/100km	0.000	200.000
PT_TC_Conslnit	0	ml		65000
PT_TC_ResetConfig_Auto	Reset available			
PT_TC_ResetConfig_Trip	Reset available			
PT_TC_ResetConfig_Trip2	Reset available			
PT_DFL_DifflockStatusSol	not available			
PT_TC_FuelConsPerHour	disabled			
PT_SBTW_SeatBeltRepetition	repetition			
PT_DFL_WorkCrawl	not available			
PT_VM_BattSensor_AVL	enabled			
paramRockOutMode	disabled			
PT_HVACC_ENGHT_AVL	not available			
PT_PPC_IntrUrb_AVL	not available			
PT_FL_AdditionalTank	NONE			
PT_TCO_GNSS_AVL	not available			
PT_OnBoardNavi_AVL	not available			
PT_DAI_DeviceRUI_AVL	not available			
PT_IVI_2ndMicro_AVL	not available			

02/15/2023 f121356

Fig. 26, Parameter Tab

March 2023
SF662 A

21.6 Set the 'PT_OnBoardNavi_AVL' parameter value to 'A0494476121-001 OnBoard navigation (App on Android Black Box ABB) available.' See Fig. 27.

Parameter	Part	Value	Units	Minimum	Maximum	Default	Access	Description
PT_ABL_MinRangeCons	(from parent)	0.720	l/100km	0.000	200.000	0.720	R1 W1	MinimumAdblueC...
PT_TC_ConstInit	(from parent)	0	ml		65000	0	R1 W1	Initial consumptio...
PT_TC_ResetConfig_Auto	(from parent)	Reset available				Reset available	R1 W1	driver resets since ...
PT_TC_ResetConfig_Trip	(from parent)	Reset available				Reset available	R1 W1	driver resets of trip...
PT_TC_ResetConfig_Trip2	(from parent)	Reset available				Reset available	R1 W1	driver resets of trip...
PT_DFL_DifflockStatusSol	(from parent)	not available				not available	R1 W1	alternative difflock...
PT_TC_FuelConsPerHour	(from parent)	disabled				disabled	R1 W1	Fuel consumption l...
PT_SBTW_SeatBeltRepetition	(from parent)	repetition				repetition	R1 W1	Seat belt warning r...
PT_DFL_WorkCrawl	(from parent)	not available				not available	R1 W1	Work and Crawl ra...
PT_VM_BattSensor_AVL	(from parent)	enabled				disabled	R1 W1	Rock-out switch vi...
paramRockOutMode	(from parent)	disabled				disabled	R1 W1	Rock-out switch vi...
PT_HVACC_ENGHT_AVL	(from parent)	not available				not available	R1 W1	HVAC independen...
PT_PPC_Inturb_AVL	(from parent)	not available				not available	R1 W1	PPC interurban ava...
PT_FL_AdditionalTank	(from parent)	NONE				NONE	R1 W1	Side of main tank
PT_TCO_GNSS_AVL	(from parent)	not available				not available	R1 W1	Control device TC...
PT_OnBoardNavi_AVL	(from parent)	A0494476121-001 OnBoard navigation (App on Android Black Box ABB) available				not available	R1 W1	OnBoard navigatio...
PT_DAI_DeviceRUI_AVL	(from parent)	A0494476021-001 OnBoard navigation (App on Android Black Box ABB) not available				not available	R1 W1	Daimler specific R...
PT_IVI_2ndMicro_AVL	(from parent)	not available				not available	R1 W1	2nd microphone a...
PT_IVI_CenterSpeaker_AVL	(from parent)	available				available	R1 W1	Center speaker ava...
PT_IVI_RearSpeakers_AVL	(from parent)	not available				not available	R1 W1	Rear Left/Right sp...
PT_IVI_Subwoofer_AVL	(from parent)	not available				not available	R1 W1	Subwoofer availab...
PT_IVI_SoundVariant	(from parent)	MB_MID_M-Cab				MB_MID_M-Cab	R1 W1	Vehicle sound vari...
PT_DFL_DiffLockSpeed1	(from parent)	31.1	mph	0.0	155.3	31.1	R1 W1	Differential Lock S...
PT_DFL_DiffLockSpeed2	(from parent)	28.0	mph	0.0	155.3	28.0	R1 W1	Differential Lock S...

Fig. 27, Setting the Parameter Value

- 21.7 Select the 'Send' button to write the parameter change to the vehicle. A window will open asking to confirm the parameter change. Select 'OK.'
- 21.8 Once the parameter change is complete, go to the 'Program Device' tab. Then select 'Unit data management' in the upper-right corner.
- 21.9 The information corresponding to the VIN should appear under 'Unit data for upload.' Select 'Connect to server' to upload the new parameters.
- 21.10 Once the parameter updates are uploaded to the server, disconnect the vehicle from DiagnosticLink.
- 22. Verify the function of the TomTom navigation.
 - 22.1 Start the engine. If the TomTom has been successfully installed and activated, the navigation icon shown in Fig. 28 is visible on the head unit display. If the navigation does not work right away, it may be necessary to cycle the key off, allow all modules to power down, and then key back on.



Fig. 28, Navigation Icon

March 2023
SF662 A

- 22.2 Select the navigation icon shown in **Fig. 28** to start the route navigation. A caution is displayed as shown in **Fig. 29**; select 'OK.'

Figure 30 shows the navigation map indicating that the navigation system is functioning.

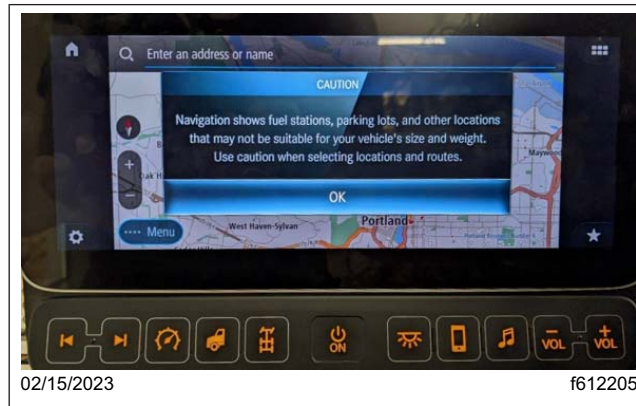

Fig. 29, Navigation Caution

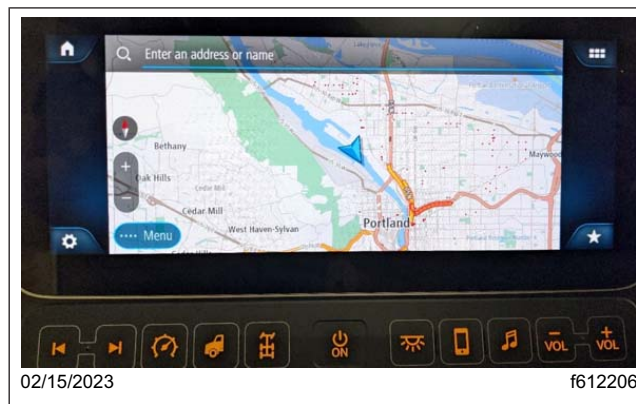

Fig. 30, Navigation Map

- 22.3 If the screens shown in **Fig. 28**, **Fig. 29**, and **Fig. 30** are displayed, then the TomTom installation is successful.
23. Clean a spot on the base label (Form WAR259) and attach a campaign completion sticker for SF662 (Form WAR261), indicating this work has been completed.