

Technical Journal

TITLE:

DIM message “Parking brake service required”

REF NO: TJ 32525.5.0	ISSUING DEPARTMENT: Technical Service	CAR MARKET: United States and Canada	
PARTNER: 3 US 7510 Volvo Car USA		ISSUE DATE: 2019-07-03	STATUS DATE: 2023-02-17
FUNC GROUP: 3760	FUNC DESC: Cable system, rear	Page 1 of 35	

“Right first time in Time”

Attachment

File Name	File Size
TJI-503688-1_1_1_en-US.pdf	3.2913 MB
TJI-503688-2_1_2_en-US.pdf	3.5582 MB
TJI-503692-2_1_1_en-US.pdf	3.8531 MB

Rows beginning with * are modified

Note! If using a printed copy of this Technical Journal, first check for the latest online version.

DESCRIPTION:

DIM = Driver Information Module

BCM = Brake Control Module

P/N = Part Number

If the DIM message “Parking Brake Service required” appears in the DIM and applicable DTC’s are present, please follow instructions under “Service”.

*Additions in this issue:

- Repair instructions with new part number to the **Right Hand Side (RHS)** for V90CC, S/V90AWD, XC60 and XC90 added.
- For V90CC, S/V90AWD, XC60, and XC90 the **Left Hand Side (LHS)** harness instructions are found in VIDA.
- Added CSC: CS.
- Added DTC’s, BCM B111167, C20071C, C200813, C200674, B111153.

Technical Journal 32525.5.0

CSC Customer Symptom Codes

Code	Description
CS	Warning lights and chimes/Parking brake indication/no indication
PK	Parking brake/No/reduced/incorrect function

DTC Diagnostic Trouble Codes

Control Module	Code	Fault Type
BCM	B111167	Permanent
BCM	B111153	Permanent
BCM	C200F29	Permanent
BCM	C200674	Permanent
BCM	C20071C	Permanent
BCM	C20081B	Permanent
BCM	C200713	Permanent
BCM	C200E29	Permanent
BCM	C200574	Permanent
BCM	C20071B	Permanent
BCM	B111177	Permanent

Vehicle Type

Type	Eng	Eng Desc	Sales	Body	Gear	Steer	Model Year	Plant	Chassis range	Struc Week Range
234							2017-2017		-	201617-201716
235							2017-2018		-	201624-201816
236							2017-2018		-	201646-201816
238							2018-2018		-	201746-201816
246							2018-2018		-	201717-201816
256							2016-2018		-	201505-201816

SERVICE:

NOTE: The DTC's may have been set due to other reasons then damaged wiring.

*Additions in this issue:

*Check wire harness for the parking brake if wires are damaged.

*Perform repair as per attached instructions or VIDA for applicable model:

Technical Journal 32525.5.0

Model	Left side			Right side		
	Instruction	P/N harness	VST OP	Instruction	P/N harness/ Kit	VST OP
XC60	VIDA	VIDA	Gen OP	TJI-503688-1_1_1	32265587	98692-2
XC90	VIDA	VIDA	Gen OP	TJI-503688-1_1_1	32265587	98692-2
V90CC	VIDA	VIDA	Gen OP	TJI-503688-1_1_1	32265587	98692-2
V90AWD	VIDA	VIDA	Gen OP	TJI-503688-1_1_1	32265587	98692-2
S90AWD	VIDA	VIDA	Gen OP	TJI-503688-1_1_1	32265587	98692-2
V90FWD	TJI-503692-2_1_1	32214494	98663-2	TJI-503688-2_1_2	32214495	98663-2
S90FWD	TJI-503692-2_1_1	32214494	98663-2	TJI-503688-2_1_2	32214495	98663-2

***Warranty claim info:**

To get warranty claim accepted for a job described in this TJ, please use following data:
VST Op number: 98663-2/98692-2 and applicable CSC and part number.

VST Operation Number

VST Operation Number	Description
98692-2	Cutting of cable harness acc. to TJ
98663-2	Cutting of cable harness acc. to TJ

VEHICLE REPORT:

Yes, please submit a Vehicle Report if the service solution described in this TJ has no effect. Use concern area “Vehicle Report” and sub concern area “Support not needed”, use function group 3760.

To view TJ attachments continue to next page. This TJ has three attachments.



Volvo Car Customer Service

TJ Instruction VCC-503688-1

Title	Joining wires, right	Page	1 (10)
Action	Product fix	Operation number:	98692-2

Issue	Date	Reason
1	2019-05	First issue

Affected vehicles

Model year	Model	Transmission
2017, 2018	S90 (17-)	TG-81SC AWD
2017, 2018	V90 (17-)	TG-81SC AWD
2017, 2018, 2019	V90 Cross Country	
2018, 2019	XC60 (18-)	
2016, 2017, 2018, 2019	XC90 (16-)	

Materials

Materials	Qty.	Part No.	Notes
Electrical tape	1	9511028	
Tape	1	9511071	
Kit	1.0	32265587	Service kit
Cable tie	10.0	983748	
Splice	2.0	9130467	

Color symbols

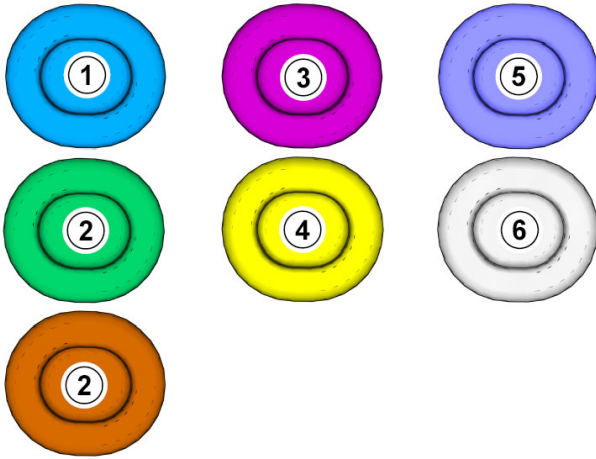

Note! This colour chart displays (in colour print and electronic version) the importance of the different colours used in the images of the method steps.

- 1 . Used for focused component, the component with which you will do something.
- 2 . Used as extra colors when you need to show or differentiate additional parts.
- 3 . Used for attachments that are to be removed/installed. May be screws, clips, connectors, etc.
- 4 . Used when the component is not fully removed from the vehicle but only hung to the side.
- 5 . Used for standard tools and special tools.
- 6 . Used as background color for vehicle components.

Removal

Set the vehicle to Inactive mode, described in user mode , refer to:

- General Information
- 3 - Electrical system
- 30 - General
- 300 - general

Remove the right rear wheel , refer to:

- Removal, replacement and installation
- 7 - Springs and wheels
- 77 - Wheels, tyres, hubs
- 770 - complete wheels

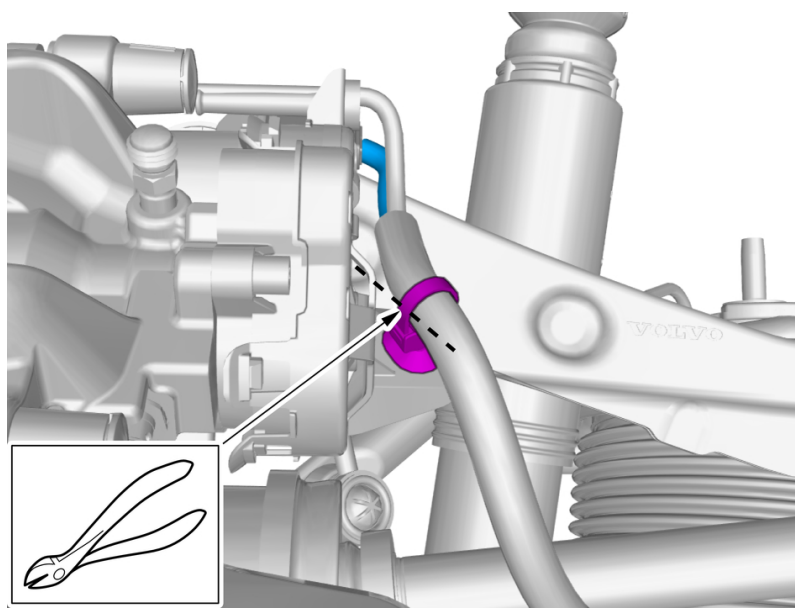

Cut following the dotted lines.
Loosen the wiring harness or move it to the side.

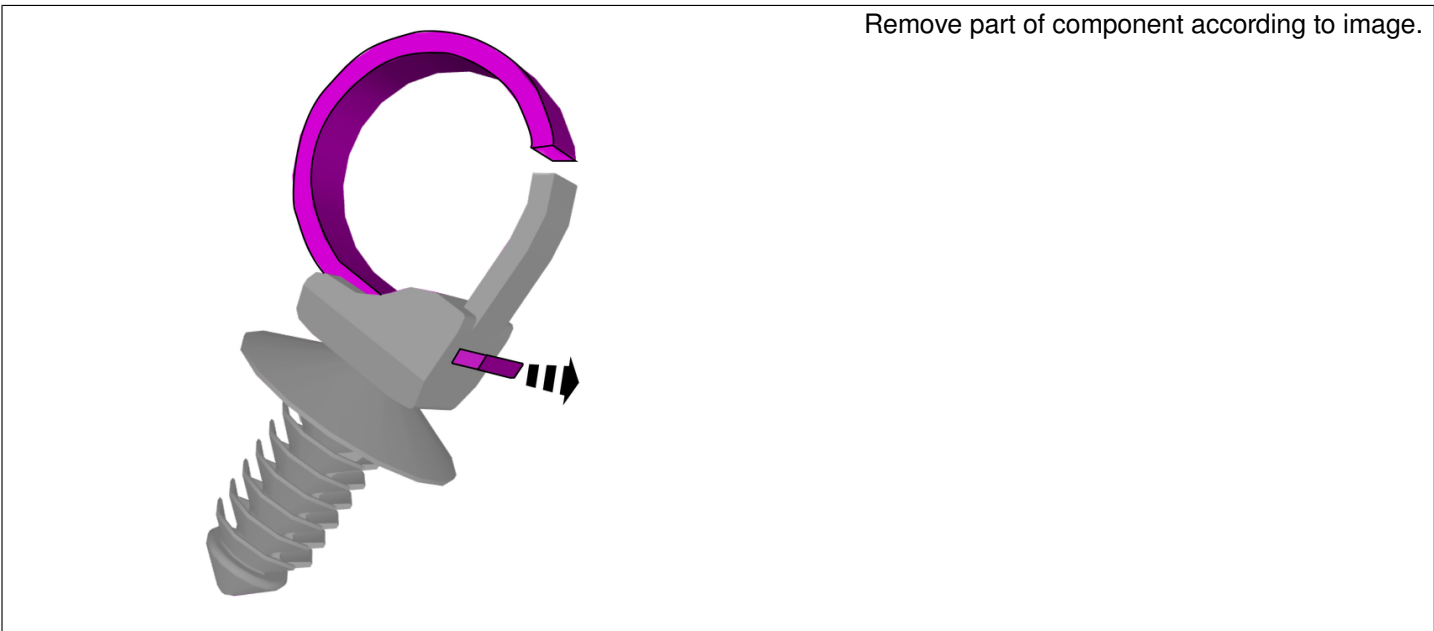

Remove part of component according to image.

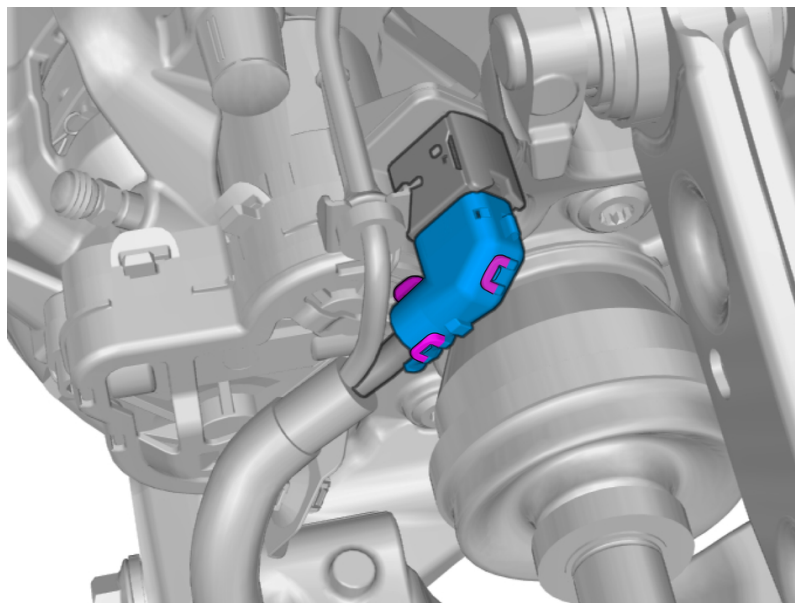

Release the catches.
Remove the marked part.
The part is not to be reused.

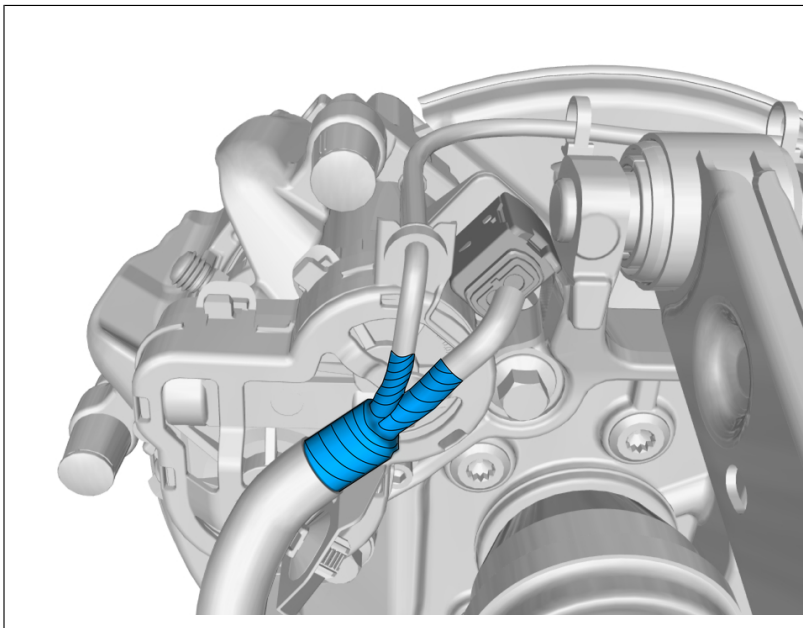

Remove the tape.

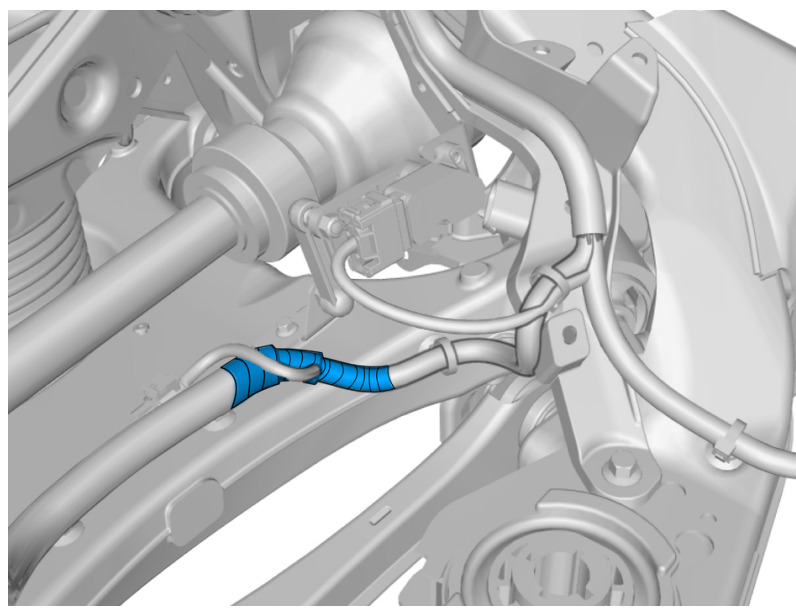

Remove the tape.

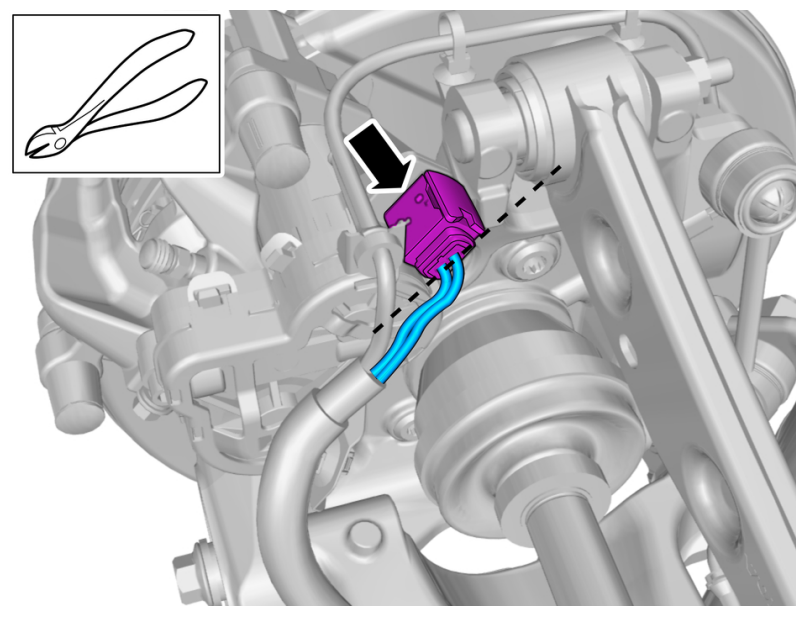

Cut following the dotted lines.
Disconnect the connector.
The part is not to be reused.

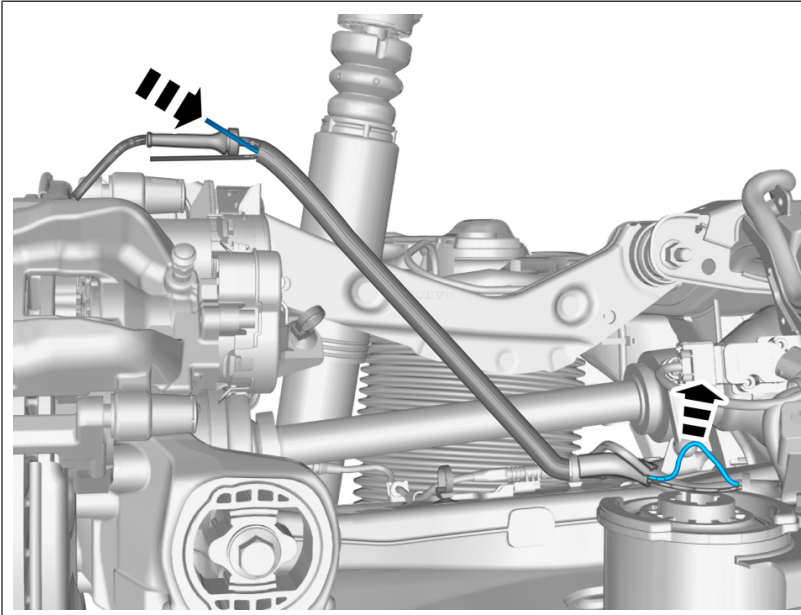

Pull the wiring through.

Installation

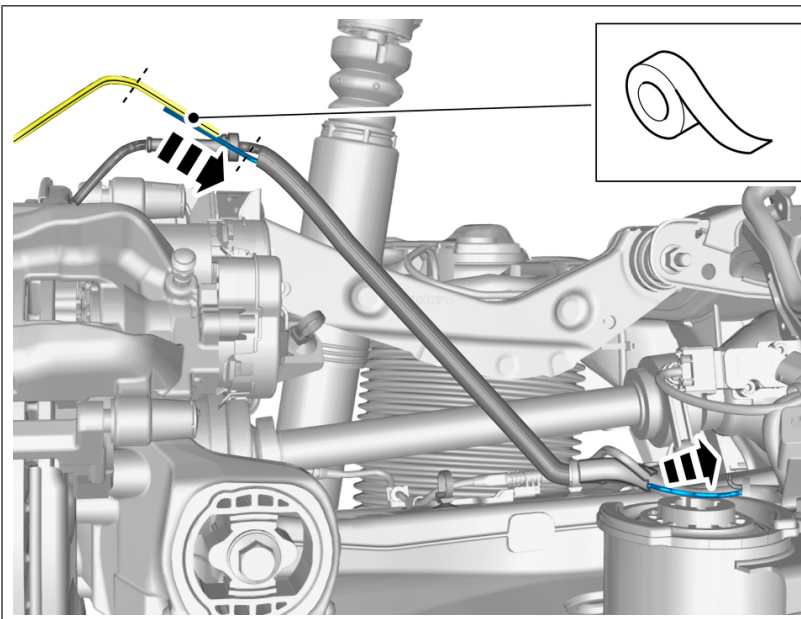

Use tape and attach the wire to the existing wiring harness.
Pull the wiring through.

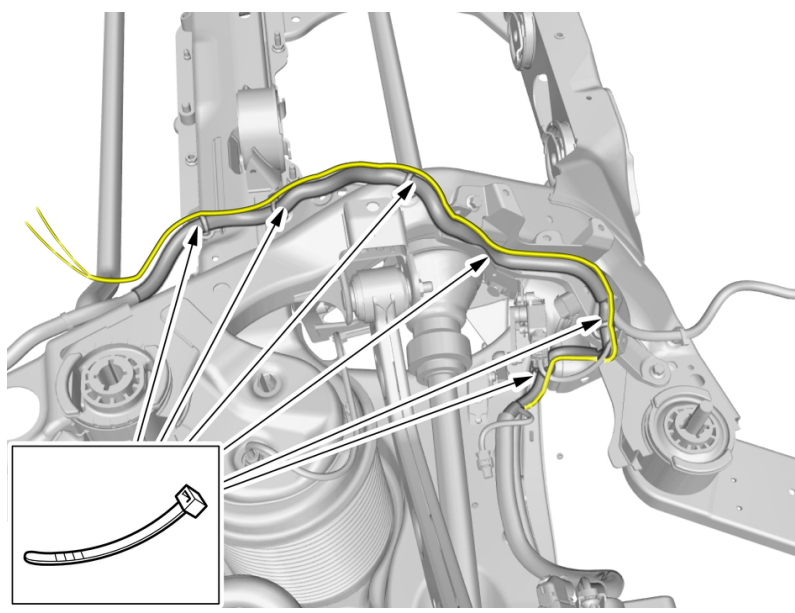

Note! Do not yet tighten the clamps.

Position wire as illustrated.

Place the cable tie as illustrated.

Connect the connector.

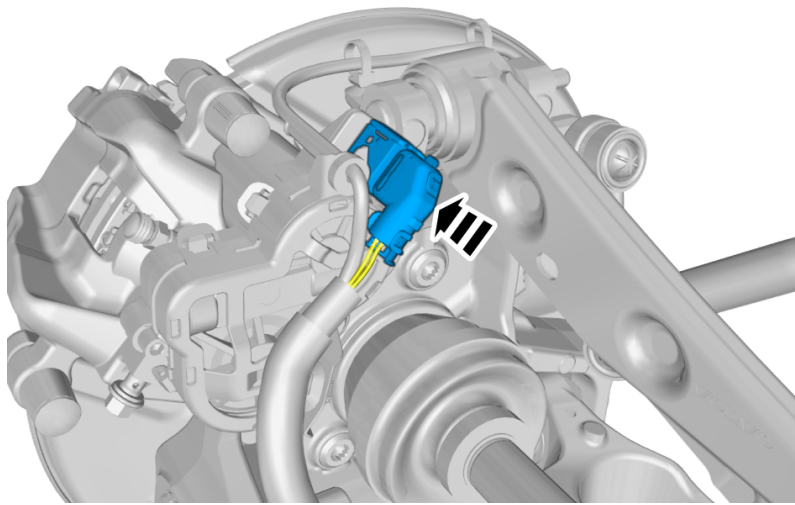

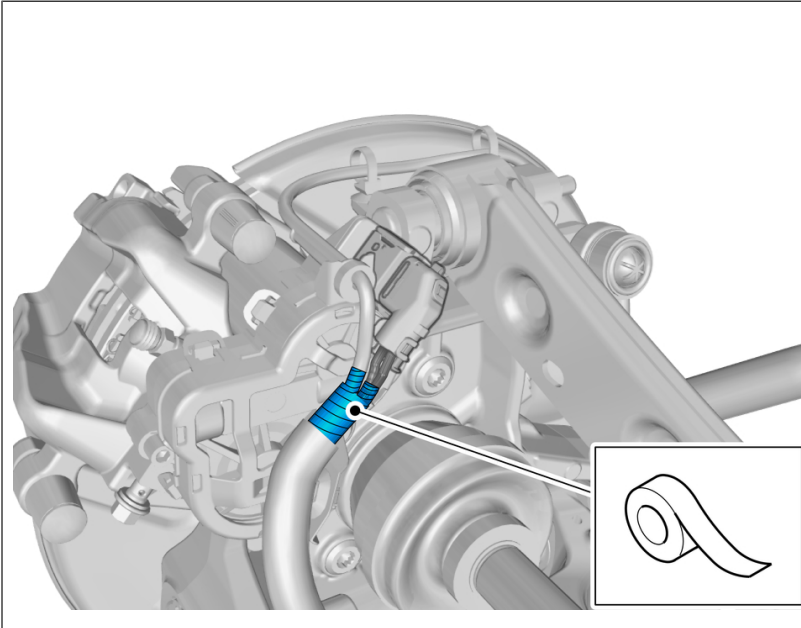

Apply tape.

- 1 · **Use:** Electrical tape , 9511028
- 2 · **Use:** Tape , 9511071

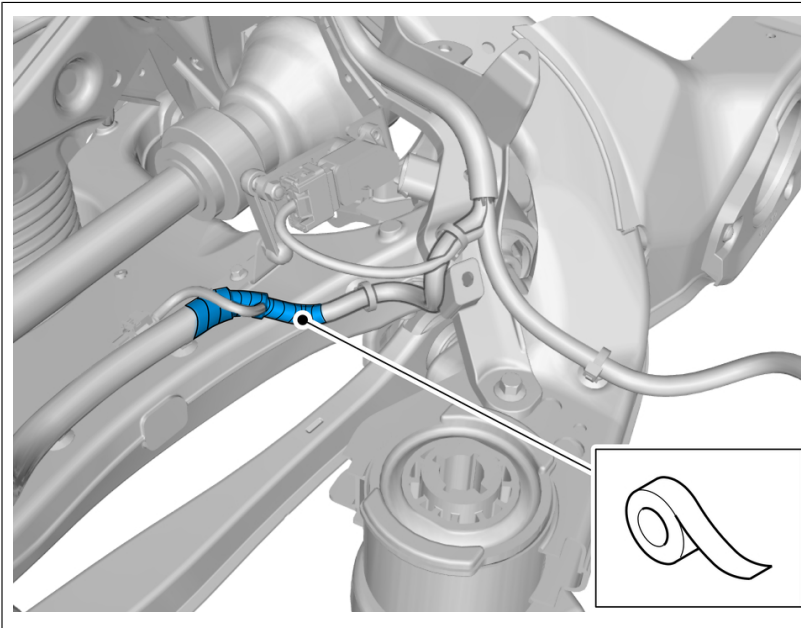

Apply tape.

- 1 · **Use:** Electrical tape , 9511028
- 2 · **Use:** Tape , 9511071

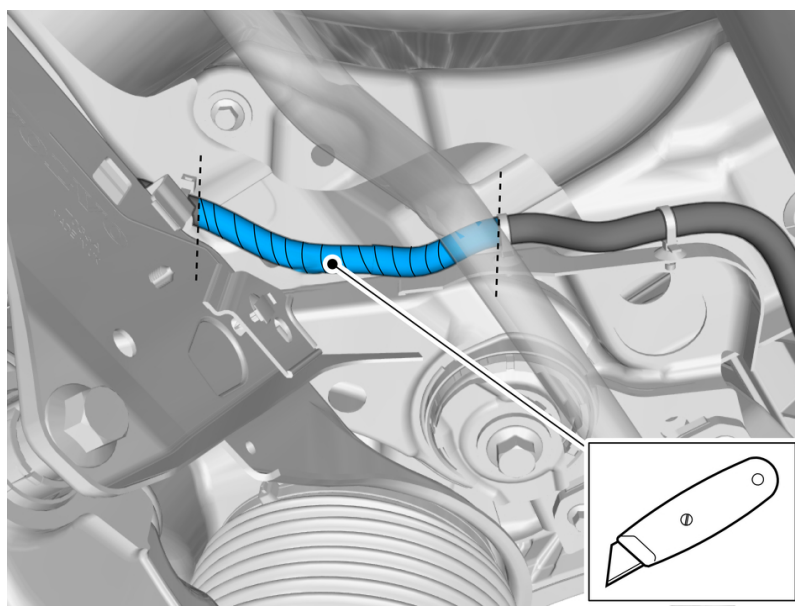

Caution! Cut carefully to avoid unintentional damage or personal injury.

Caution! Ensure that the cable/cables are not damaged.

Remove any tape or tape residue.

Carry out splicing of wire , refer to:
Product Fix/Special Tool Bulletins
3 - Electrical system
37 - Cables and fuses
376 - cable system, rear

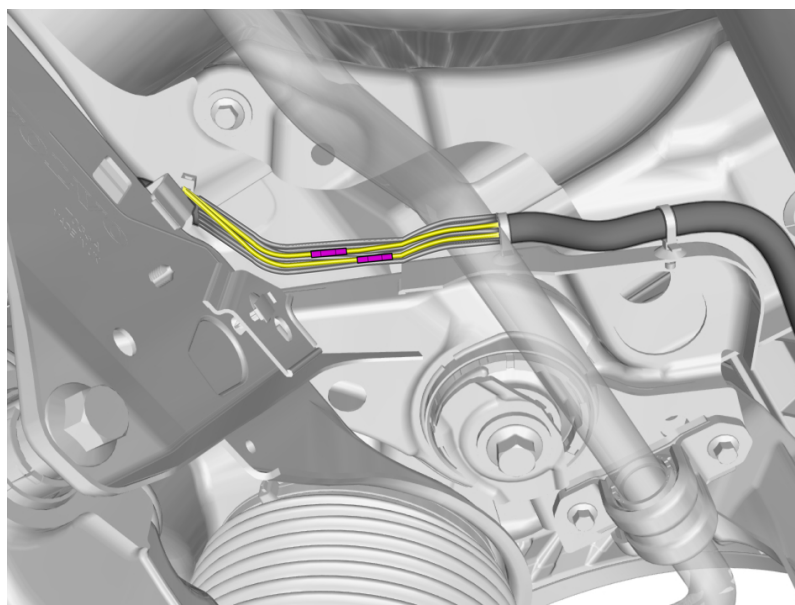

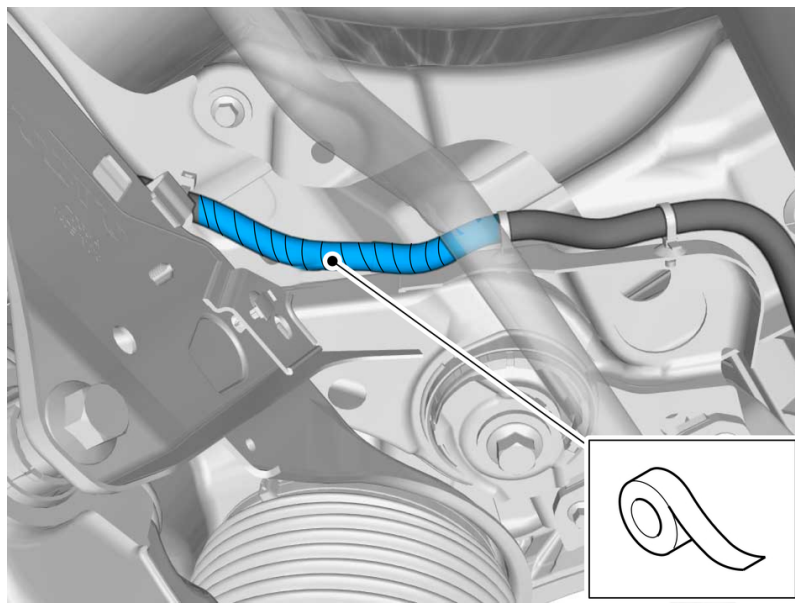

Apply tape.

- 1 · **Use:** Electrical tape , 9511028
- 2 · **Use:** Tape , 9511071

Tighten the cable ties.



Volvo Car Customer Service

TJ Instruction VCC-503692-2

Title	Joining wires, left	Page	1 (11)
Action	Product fix	Operation number:	98663-2

Issue	Date	Reason
1	2017-05	First issue
2	2018-01	Materials list change

Affected vehicles

Model year	Model
2017, 2018	S90 (17-)
2017, 2018	V90 (17-)

Materials

Materials	Qty.	Part No.	Notes
Strip clamp	1.0	983671	
Electrical tape	0.1	9511028	Consumable;
Tape	0.1	9511071	Consumable;
Kit	1.0	32214494	

Equipment

Designation	Part No.
Angle drill machine	

Removal

Note! Removal steps in this procedure may contain installation details.

Orientation view

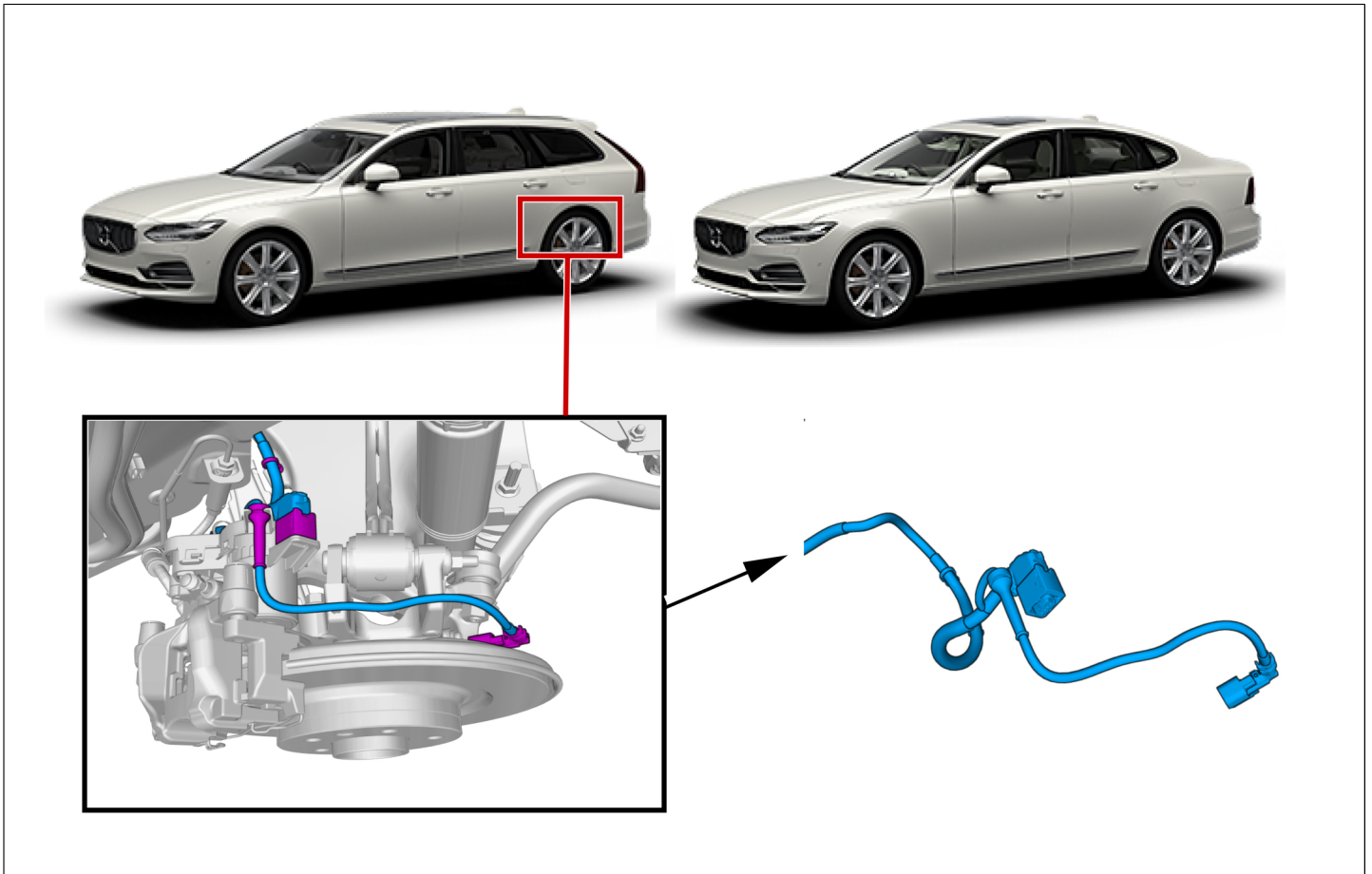

Color symbols

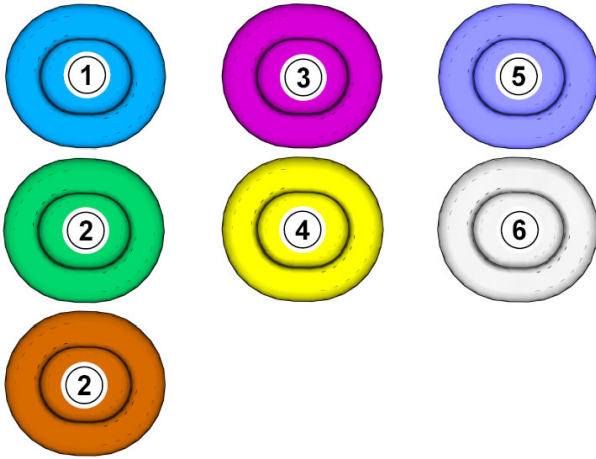

Note! This colour chart displays (in colour print and electronic version) the importance of the different colours used in the images of the method steps.

- 1 . Used for focused component, the component with which you will do something.
- 2 . Used as extra colors when you need to show or differentiate additional parts.
- 3 . Used for attachments that are to be removed/installed. May be screws, clips, connectors, etc.
- 4 . Used when the component is not fully removed from the vehicle but only hung to the side.
- 5 . Used for standard tools and special tools.
- 6 . Used as background color for vehicle components.

Set the vehicle to Inactive mode, described in user mode , refer to:

- General Information
- 3 - Electrical system
- 30 - General
- 300 - general

Remove the left rear wheel , refer to:

- Removal, replacement and installation
- 7 - Springs and wheels
- 77 - Wheels, tyres, hubs
- 771 - wheel and wheel trim

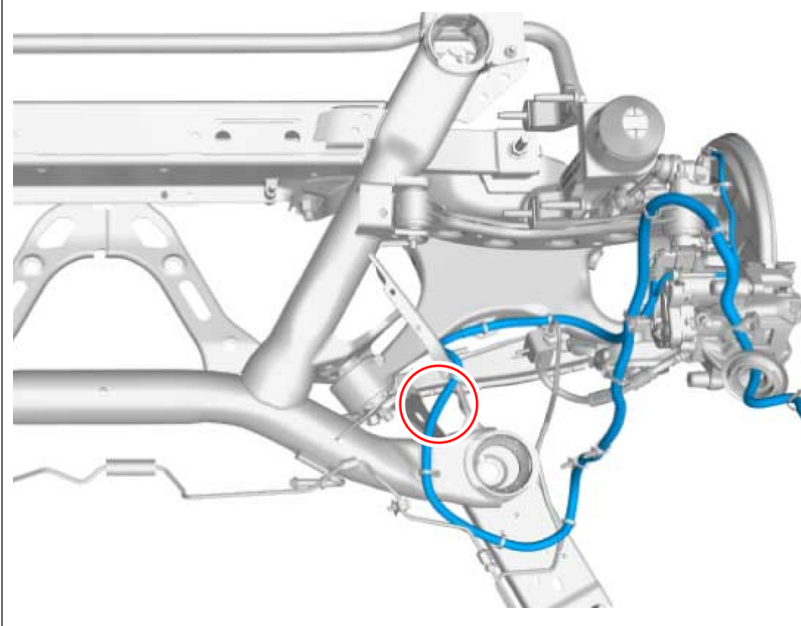

Note! Orientation view

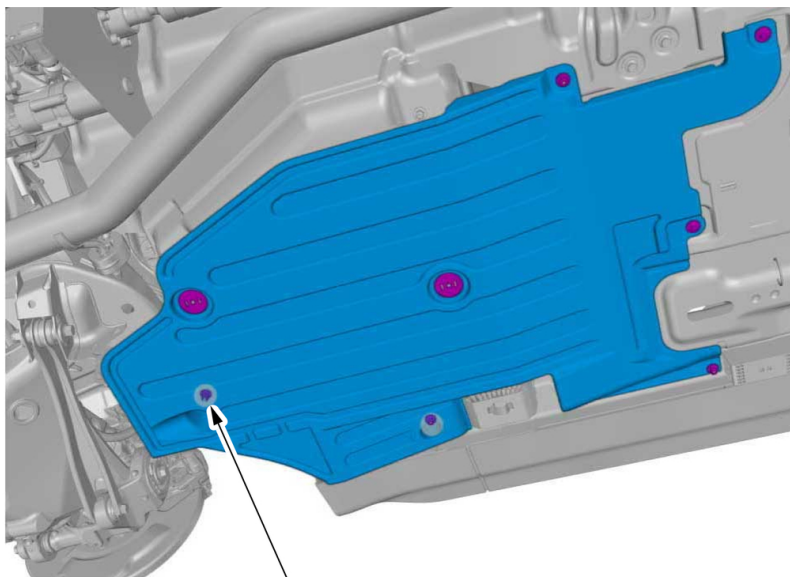

Remove the screws.
Remove the clips.
Remove the marked part.

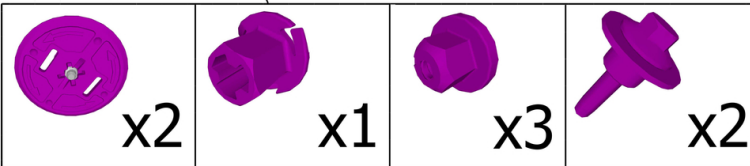

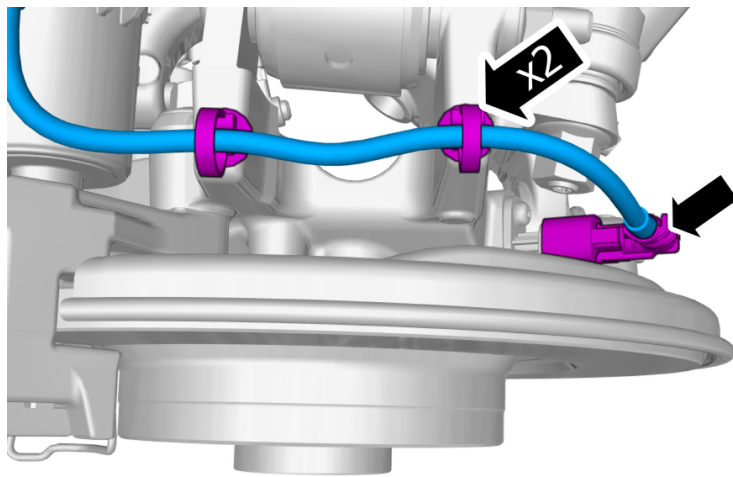

Loosen the clips.
Disconnect the connector.

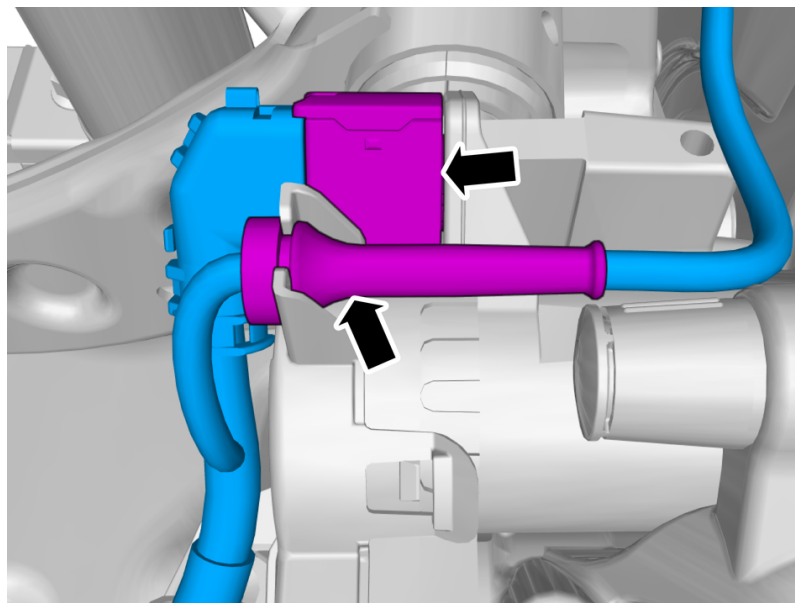

Disconnect the connector.
Loosen the fastener.

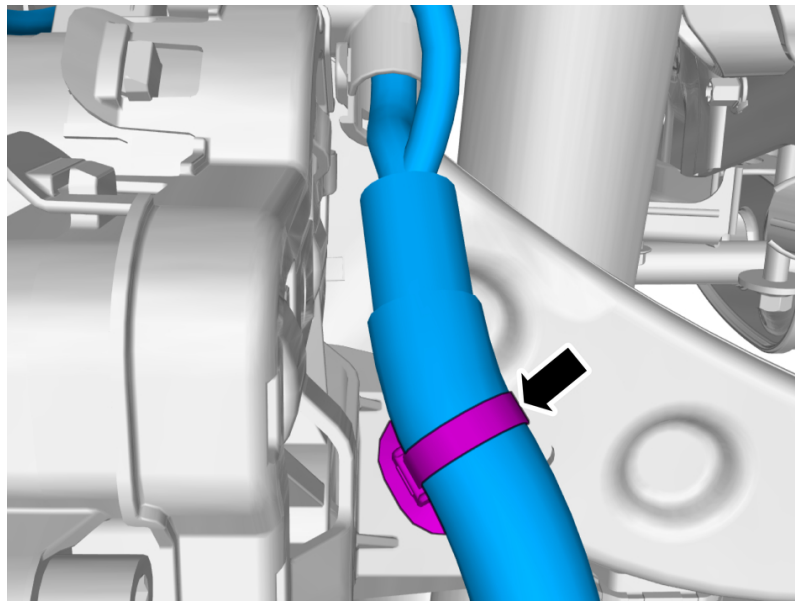

Loosen the clip.

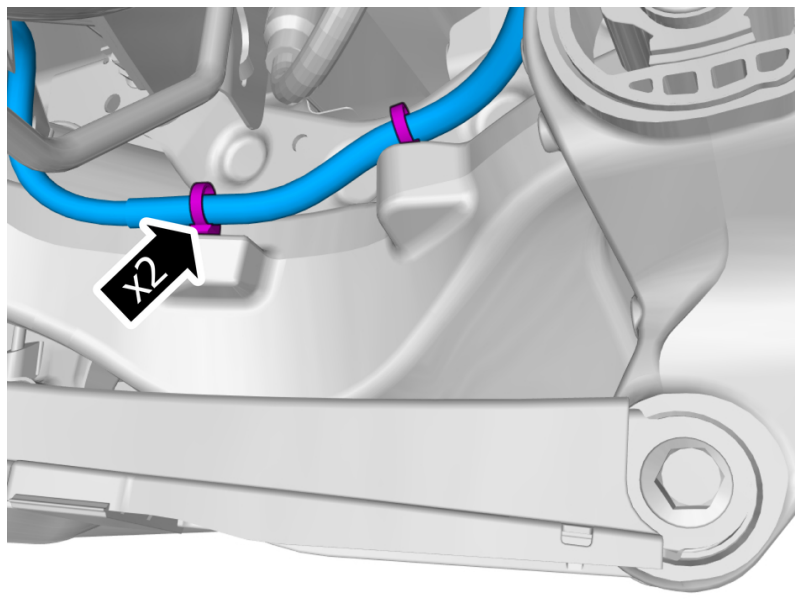

Loosen the clips.

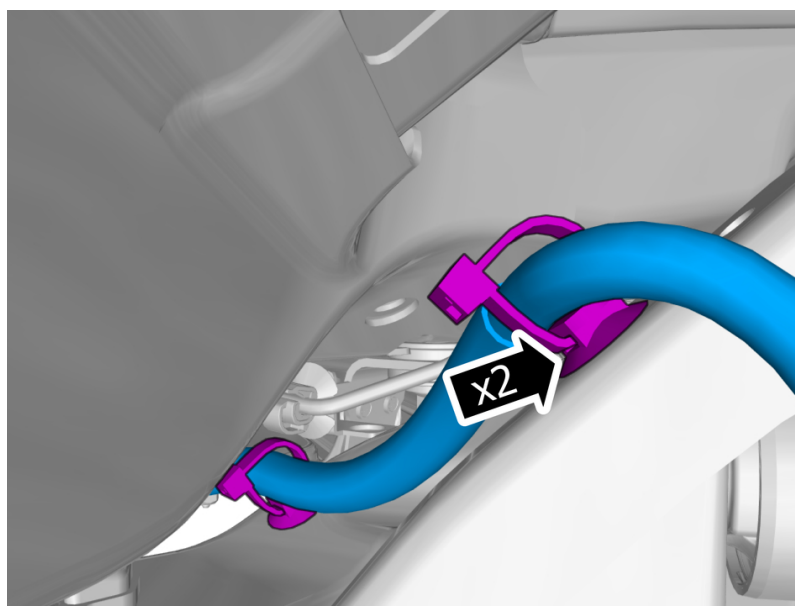

Note! Make sure that a new component is installed.

Loosen the clips.

Use: Strip clamp , 983671

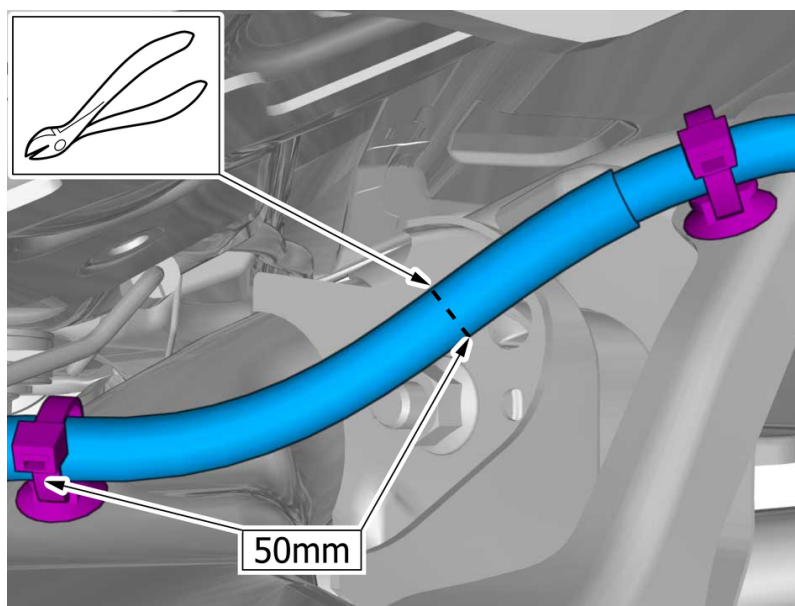

Cut

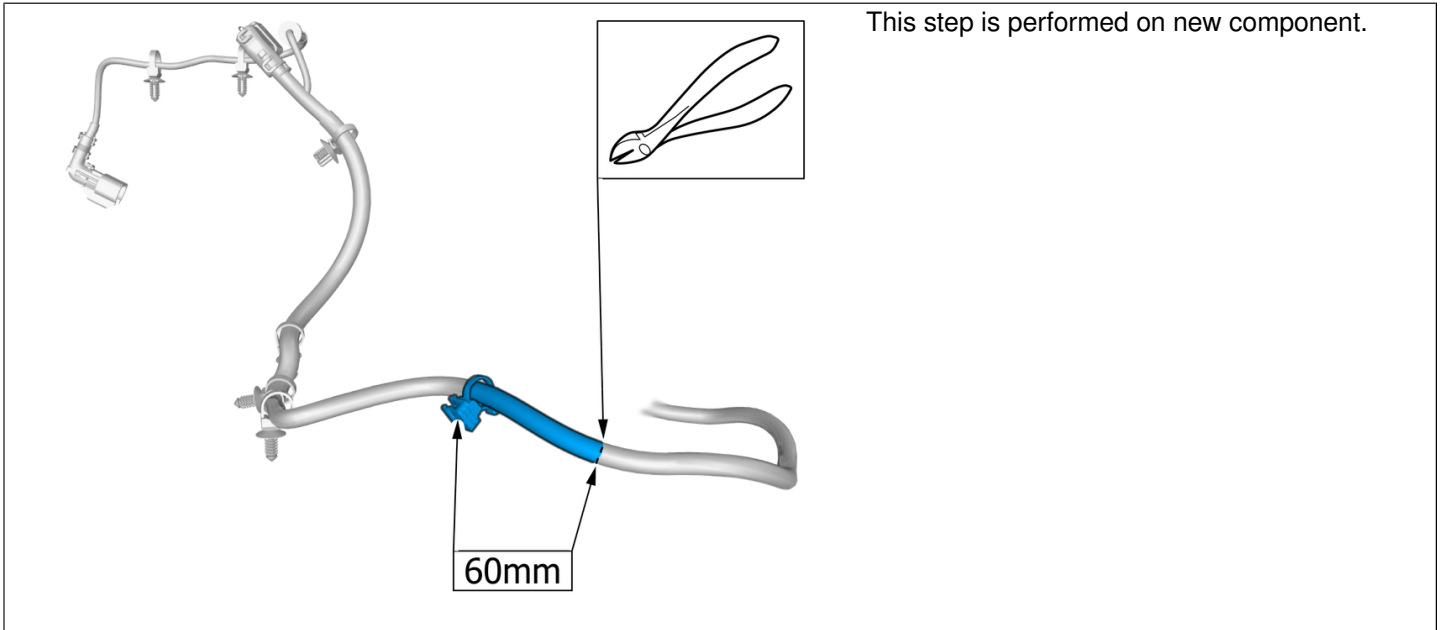

Installation

Carry out splicing of wire , refer to:
Cleaning, Inspection and Adjustment
3 - Electrical system
37 - Cables and fuses
371 - cables

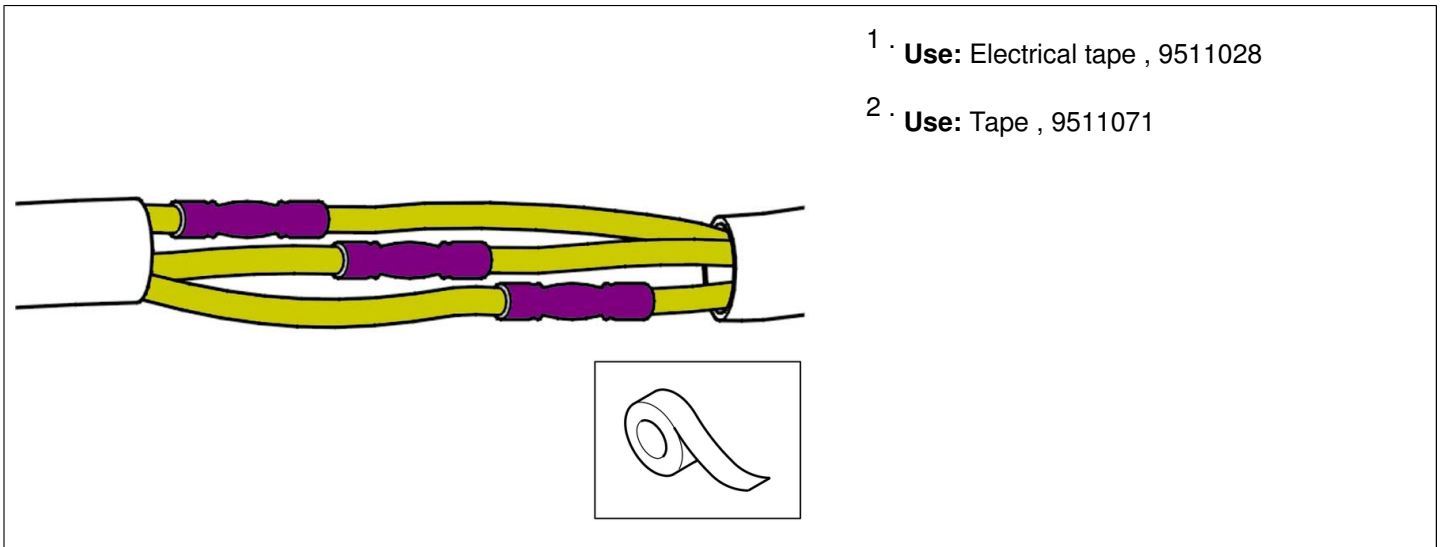

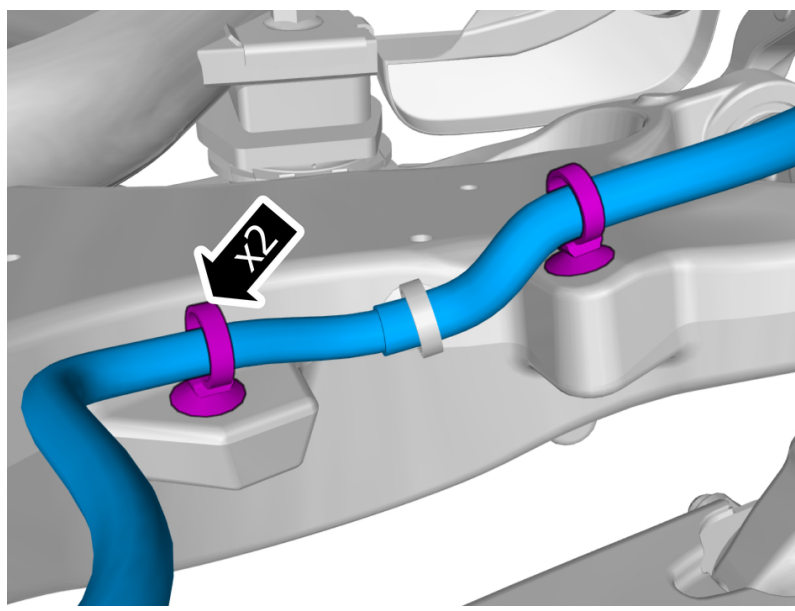

Position wire as illustrated.
Install the clip(s).

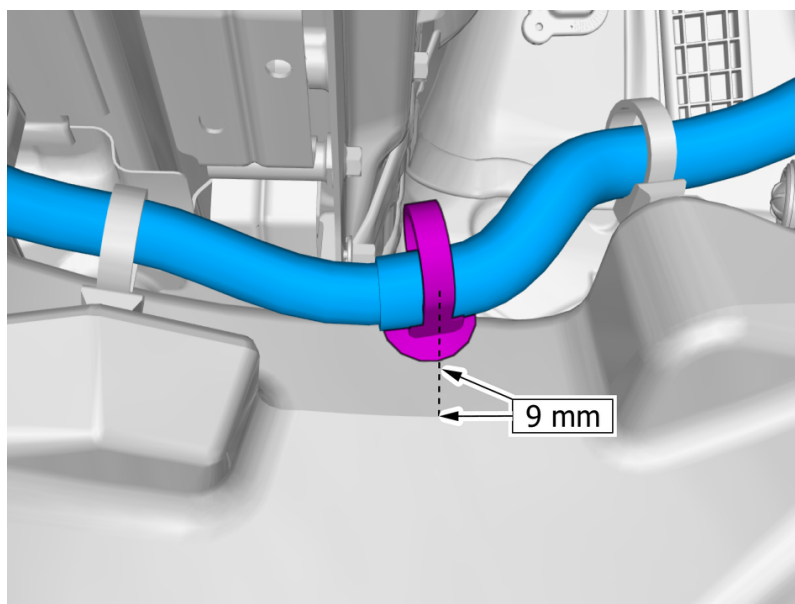

Measure from upper flange edge.
Mark using a pen

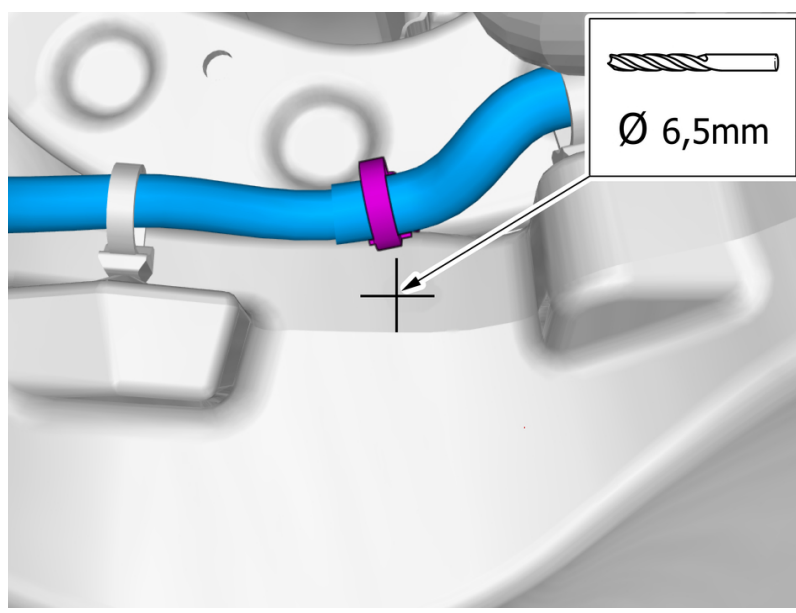

Position wire as illustrated.
Use: Angle drill machine

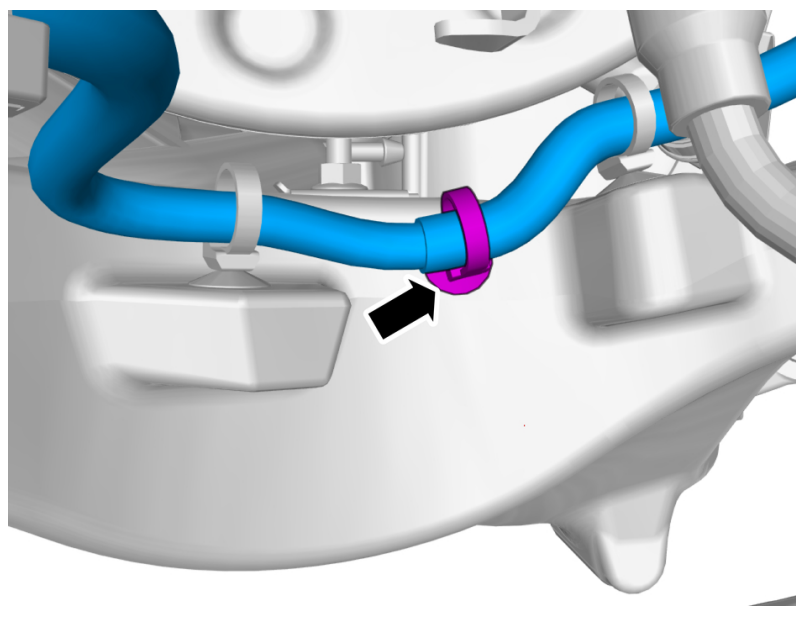

Install the clip(s).

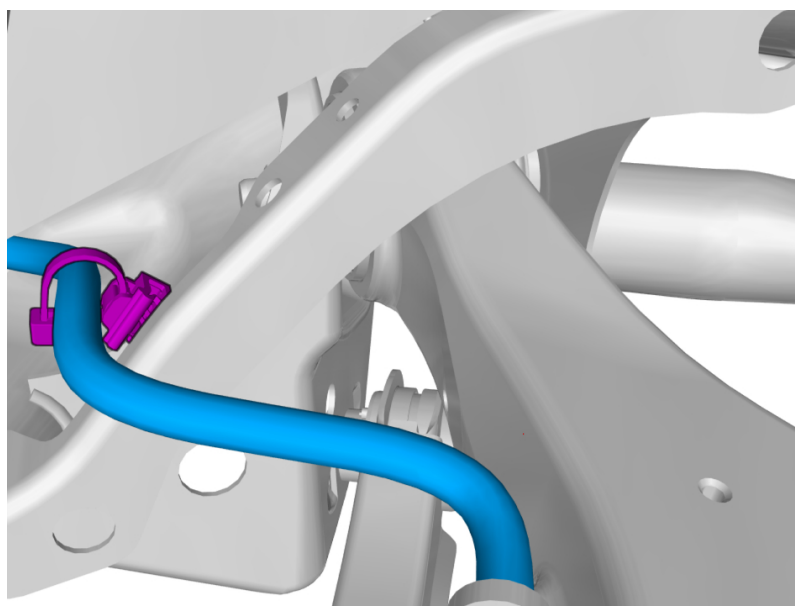

Position wire as illustrated.

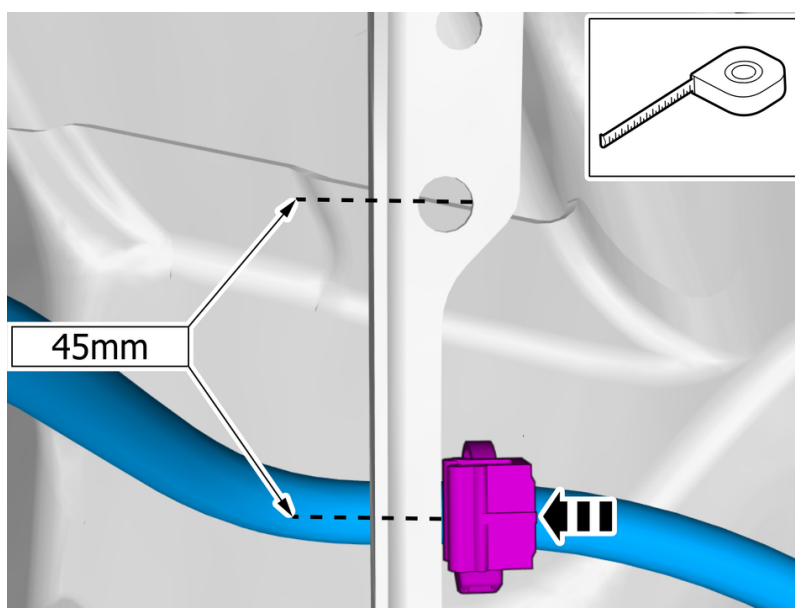

View from below
Mark using a pen
Install the clip(s).

To install, reverse the removal procedure.



Volvo Car Customer Service

TJ Instruction VCC-503688-2

Title	Joining wires, right	Page	1 (11)
Action	Product fix	Operation number:	98663-2

Issue	Date	Reason
2	2018-01	Materials list change
1	2017-05	First issue

Affected vehicles

Model year	Model
2017, 2018	S90 (17-)
2017, 2018	V90 (17-)

Materials

Materials	Qty.	Part No.	Notes
Electrical tape	0.1	9511028	Consumable;
Tape	0.1	9511071	Consumable;
Kit	1.0	32214495	

Equipment

Designation	Part No.
Angle drill machine	

Removal

Note! Removal steps in this procedure may contain installation details.

Orientation view

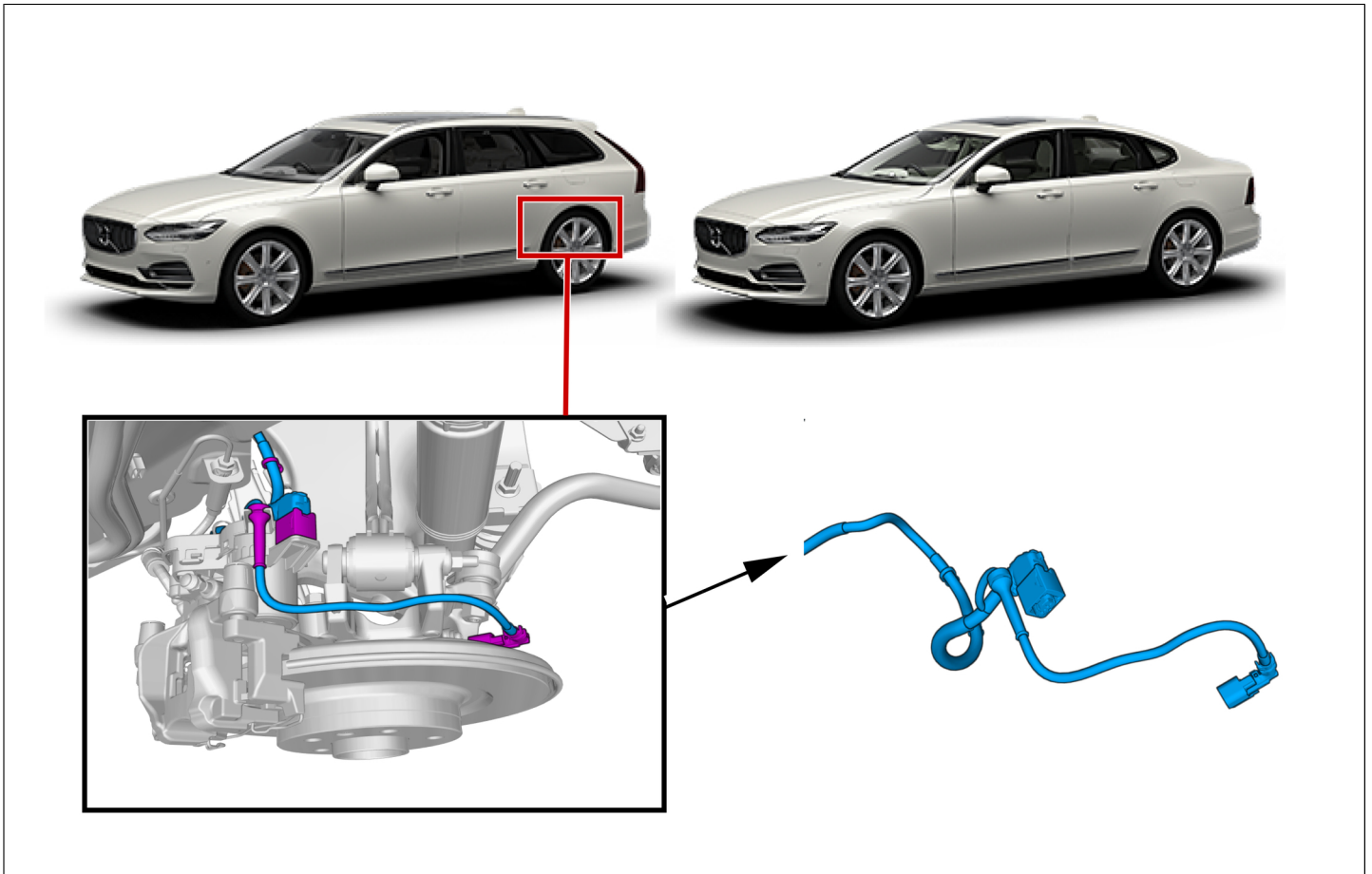

Color symbols

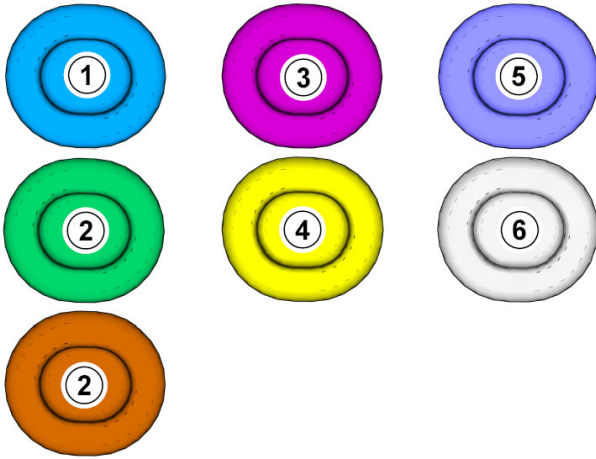

Note! This colour chart displays (in colour print and electronic version) the importance of the different colours used in the images of the method steps.

- 1 . Used for focused component, the component with which you will do something.
- 2 . Used as extra colors when you need to show or differentiate additional parts.
- 3 . Used for attachments that are to be removed/installed. May be screws, clips, connectors, etc.
- 4 . Used when the component is not fully removed from the vehicle but only hung to the side.
- 5 . Used for standard tools and special tools.
- 6 . Used as background color for vehicle components.

Set the vehicle to Inactive mode, described in user mode , refer to:

- General Information
- 3 - Electrical system
- 30 - General
- 300 - general

Remove the right rear wheel , refer to:

- Removal, replacement and installation
- 7 - Springs and wheels
- 77 - Wheels, tyres, hubs
- 771 - wheel and wheel trim

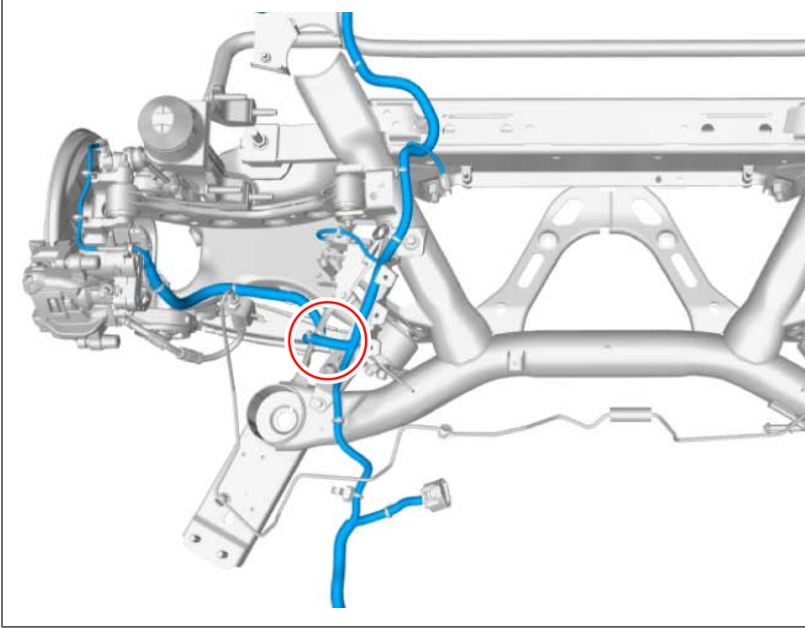

Note! Orientation view

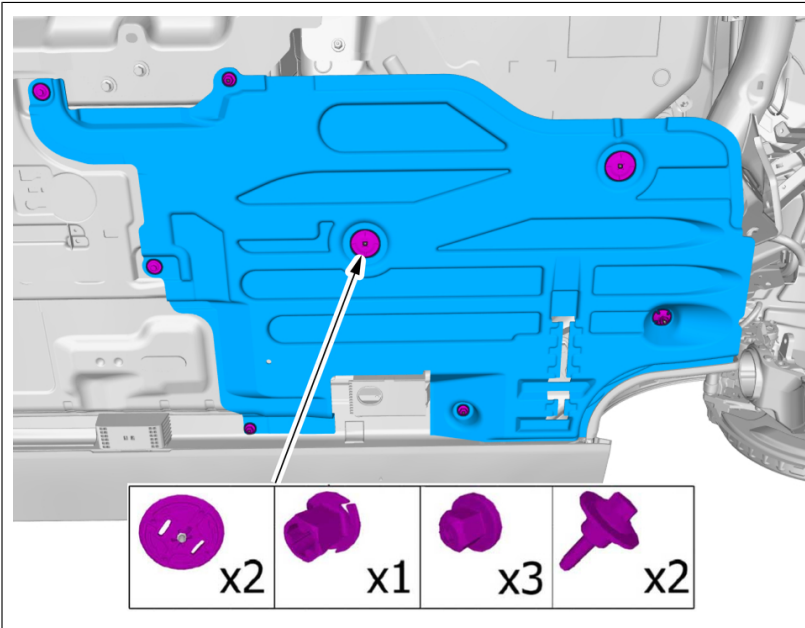

Remove the screws.
Remove the clips.
Remove the marked part.

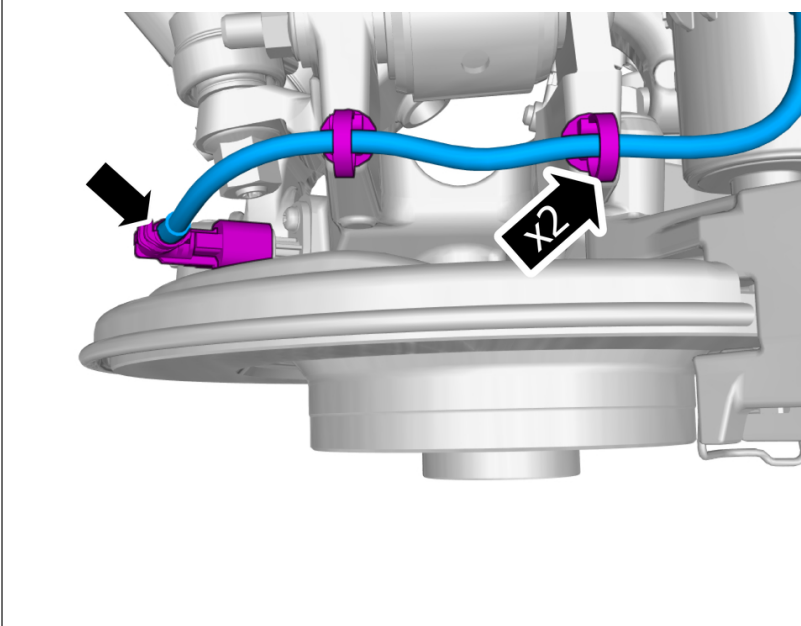

Loosen the clips.
Disconnect the connector.

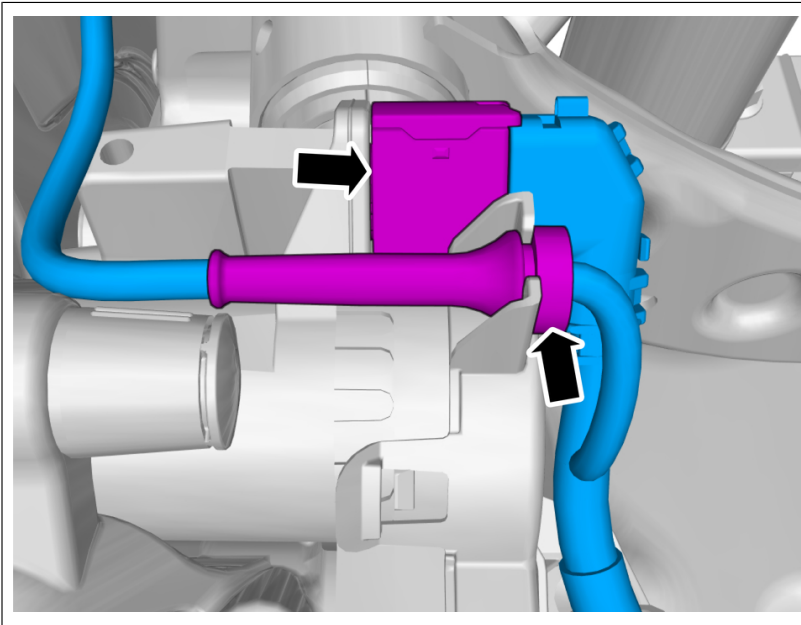

Disconnect the connector.
Loosen the fastener.

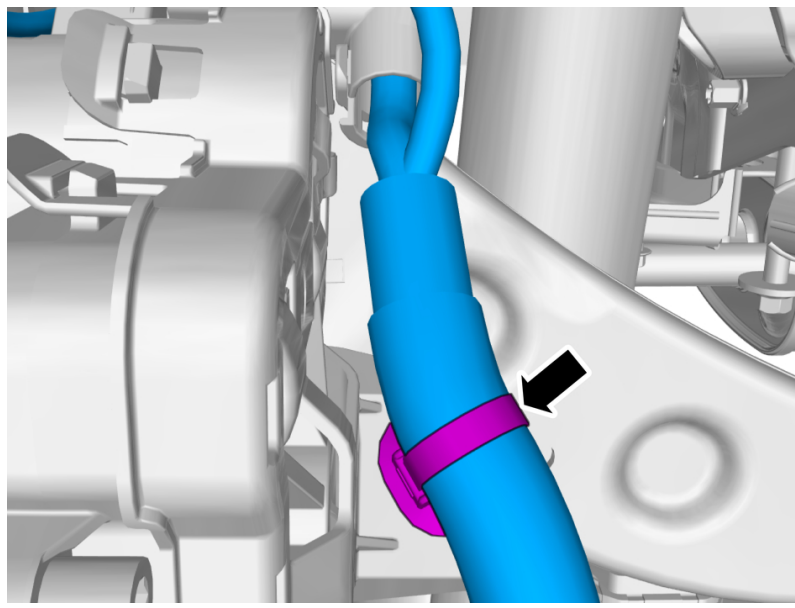

Loosen the clip.

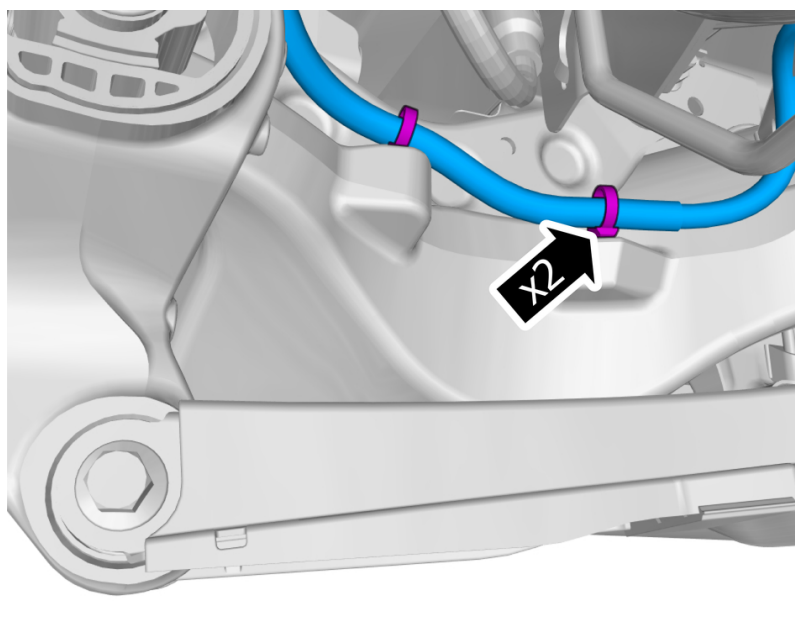

Loosen the clips.

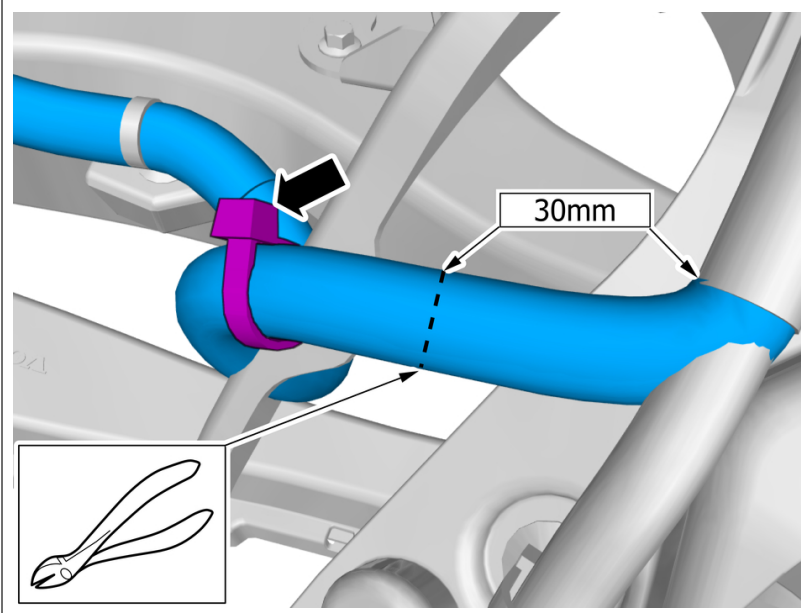

Loosen the clip.
Cut

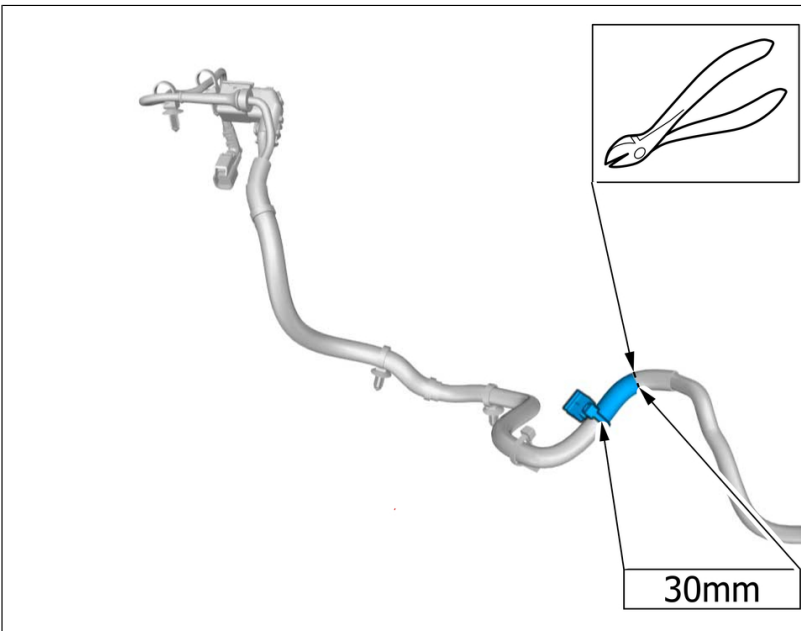

This step is performed on new component.

Installation

Carry out splicing of wire , refer to:
Cleaning, Inspection and Adjustment
3 - Electrical system
37 - Cables and fuses
371 - cables

- 1 · **Use:** Electrical tape , 9511028
- 2 · **Use:** Tape , 9511071

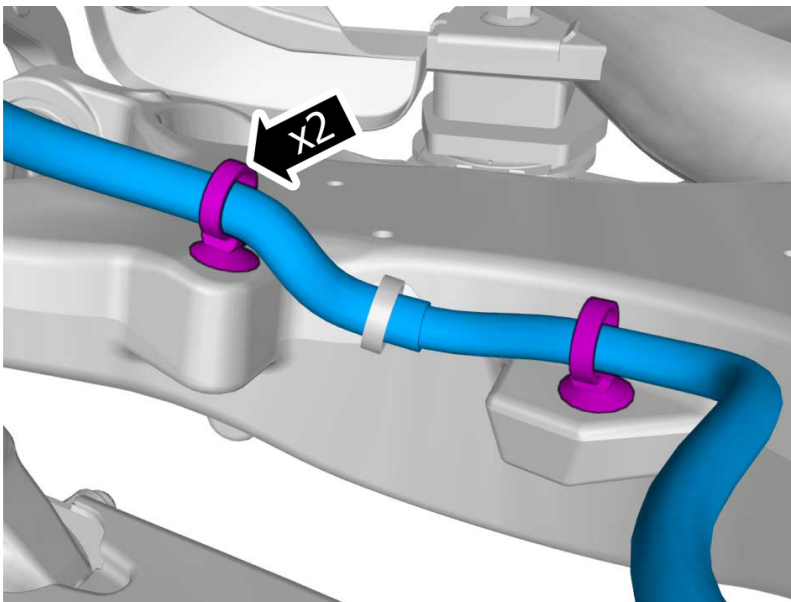
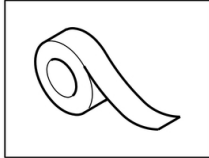
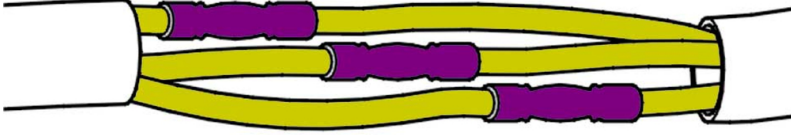

Position wire as illustrated.
Install the clip(s).

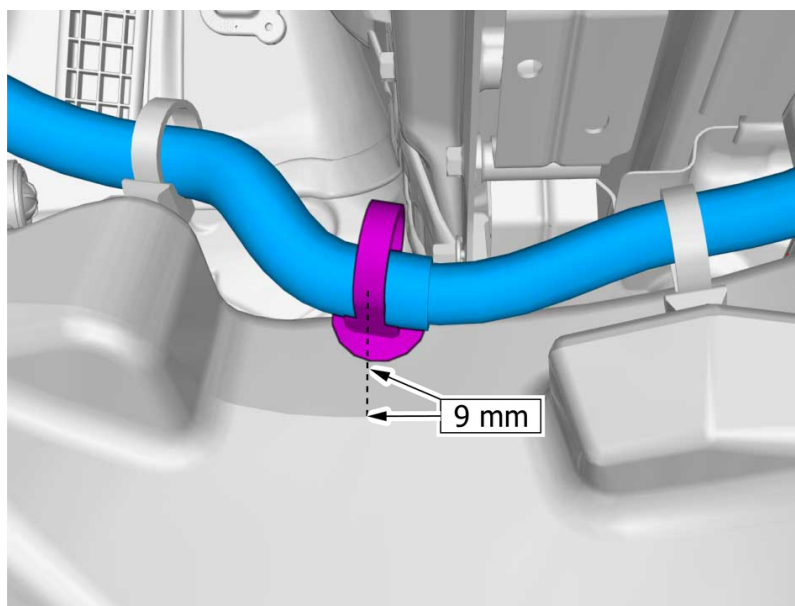

Measure from upper flange edge.
Mark using a pen

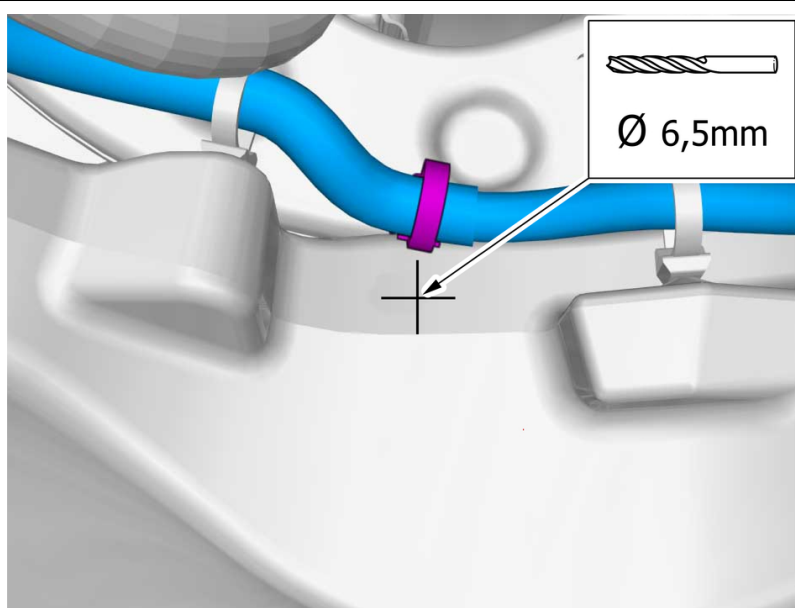

Position wire as illustrated.
Use: Angle drill machine

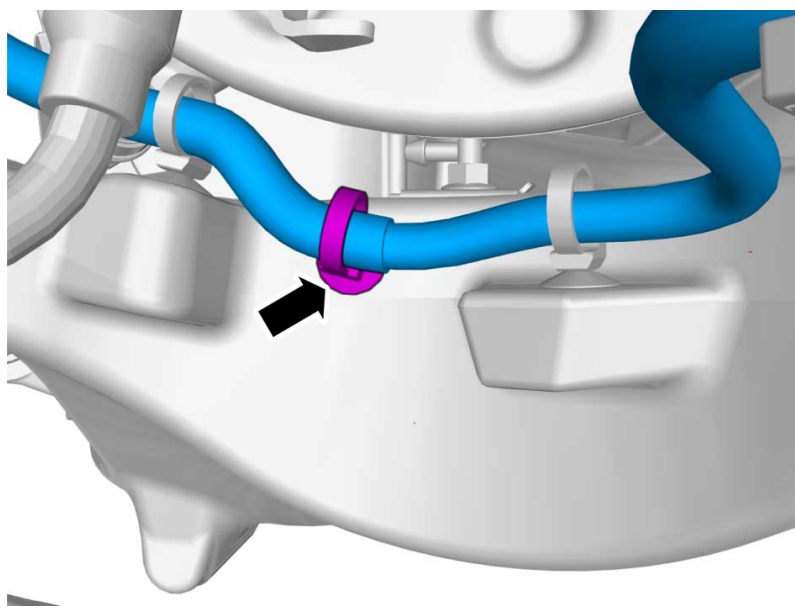

Install the clip(s).

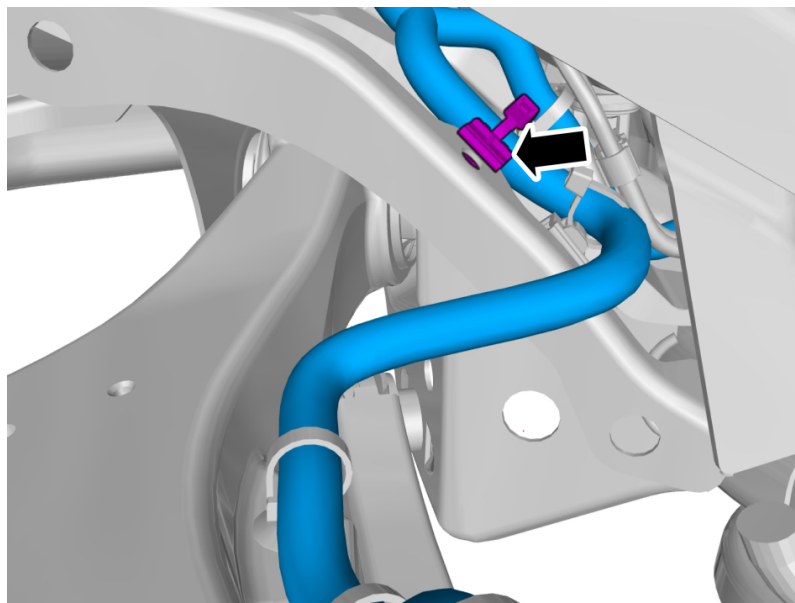

Position wire as illustrated.
Install the clip(s).

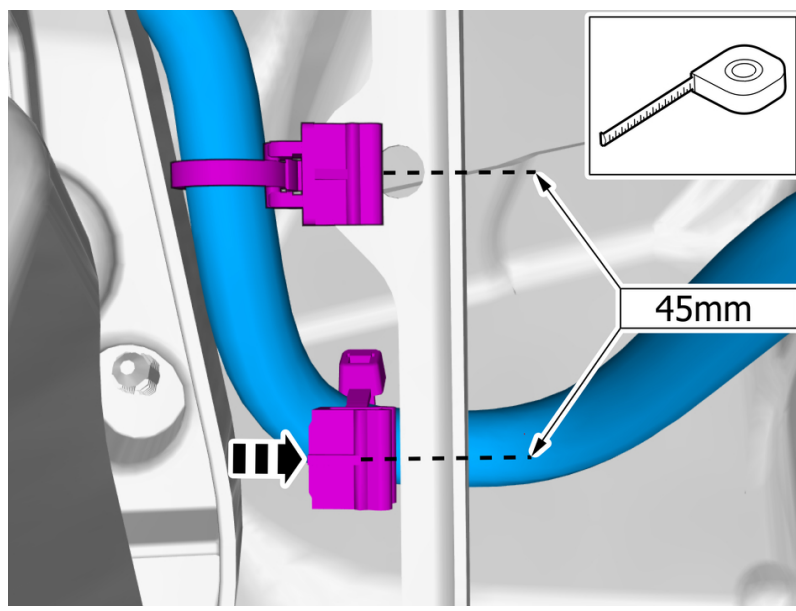

View from below
Mark using a pen
Install the clip(s).

To install, reverse the removal procedure.