

March 1, 2023

Version 1

## Engine Does Not Crank

### AFFECTED VEHICLES

Year	Model	Trim	VIN Range
2016–20	MDX	ALL	ALL

### SYMPTOM

The engine will not crank on the initial startup attempt after the vehicle has been exposed to precipitation and then freezing temperatures.

### POSSIBLE CAUSE

Water can enter the starter motor. In cold temperatures the water can freeze, preventing the starter motor from cranking the engine.

### CORRECTIVE ACTION

Replace the starter motor assembly if needed.

### PARTS INFORMATION

Part Name	Part Number	Quantity
Starter Motor Assembly	31200-5J2-305	1
Flange Bolt (12x45)	90165-SDA-A00	2
Flange Bolt (12x120)	90051-5J4-000	1
Power Relay Assembly	39794-T5A-J01	2

### TOOLS INFORMATION

Part Name	Part Number	Quantity
Relay Puller	07AAC-000A2A1	1

**CLIENT INFORMATION:** The information in this bulletin is intended for use only by skilled technicians who have the proper tools, equipment, and training to correctly and safely maintain your vehicle. These procedures should not be attempted by "do-it-yourselfers," and you should not assume this bulletin applies to your vehicle, or that your vehicle has the condition described. To determine whether this information applies, contact an authorized Acura automobile dealer.

## WARRANTY CLAIM INFORMATION

The normal warranty applies.

Operation Number	Description	Flat Rate Time	Defect Code	Symptom Code	Template ID	Failed Part Number
1161J0	Replace Starter motor assembly and relays (includes inspection)	0.9 hr	01601	03217	B23009A	31200-5J2-A53

## INSPECTION PROCEDURE

1. Confirm that the engine does not crank.
2. Inspect the starter motor for signs of icing. If icing is found, warm up the starter motor either by gently applying heat or allowing the vehicle to thaw inside the shop environment.
3. After the thawing period, attempt to crank/start the engine.
  - If the engine starts, go to REPAIR PROCEDURE.
  - If the engine doesn't crank/start, continue with normal troubleshooting.

## REPAIR PROCEDURE

1. Open the hood.
2. Remove the front bulkhead cover.

*2014-2016 MY*

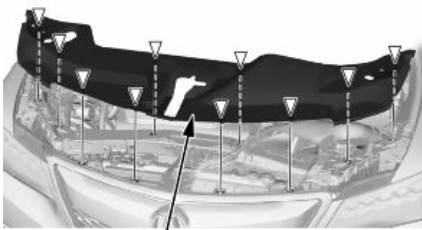

**FRONT BULKHEAD COVER**

*2017-2020 MY*

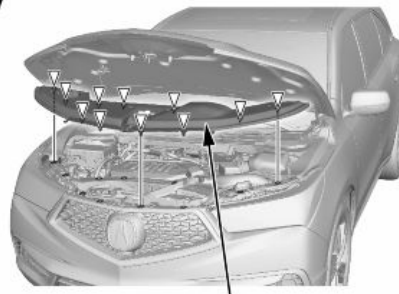

**FRONT BULKHEAD COVER**

3. Remove the air intake tube.

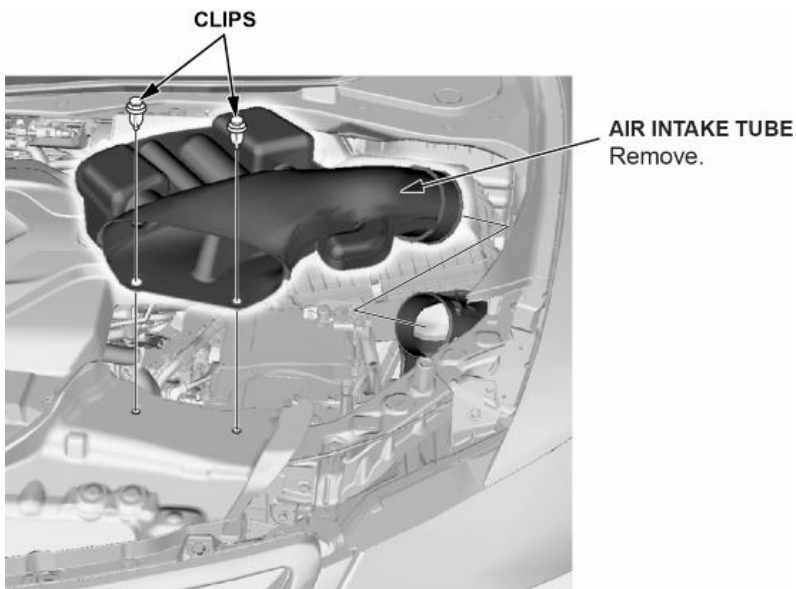

4. Disconnect the 12 volt battery.

4.1. Make sure the vehicle is in the OFF (LOCK) mode.

4.2. Disconnect and isolate the negative cable with the 12 volt battery sensor from the 12 volt battery.

NOTE:

- Always disconnect the negative side first.
- To protect the battery sensor connector from damage, do not hold it when removing the negative terminal.
- Do not disconnect the battery sensor from the negative terminal.

4.3. Disconnect the positive cable from the battery.

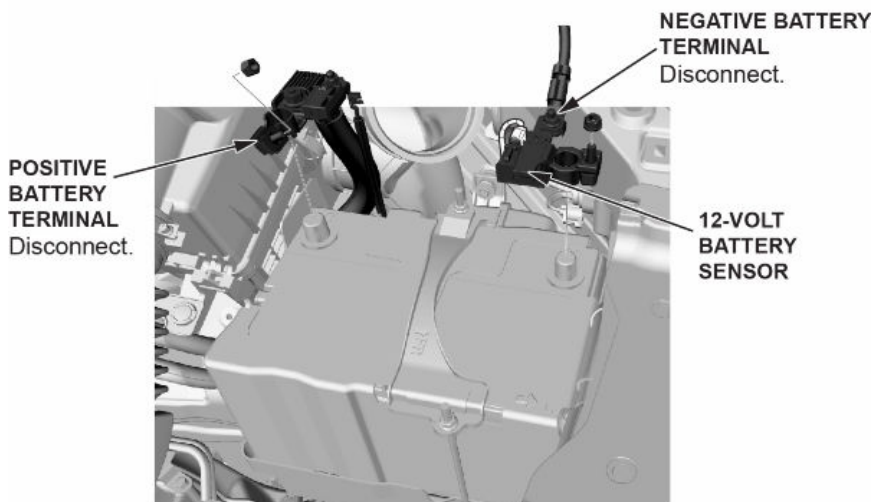

5. Disconnect the battery fan.

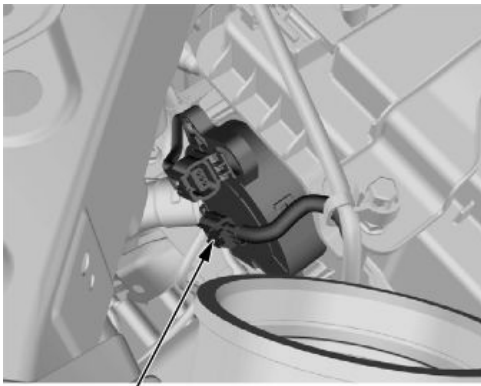

**CONNECTOR**  
Disconnect.

6. Remove the 12 volt battery.

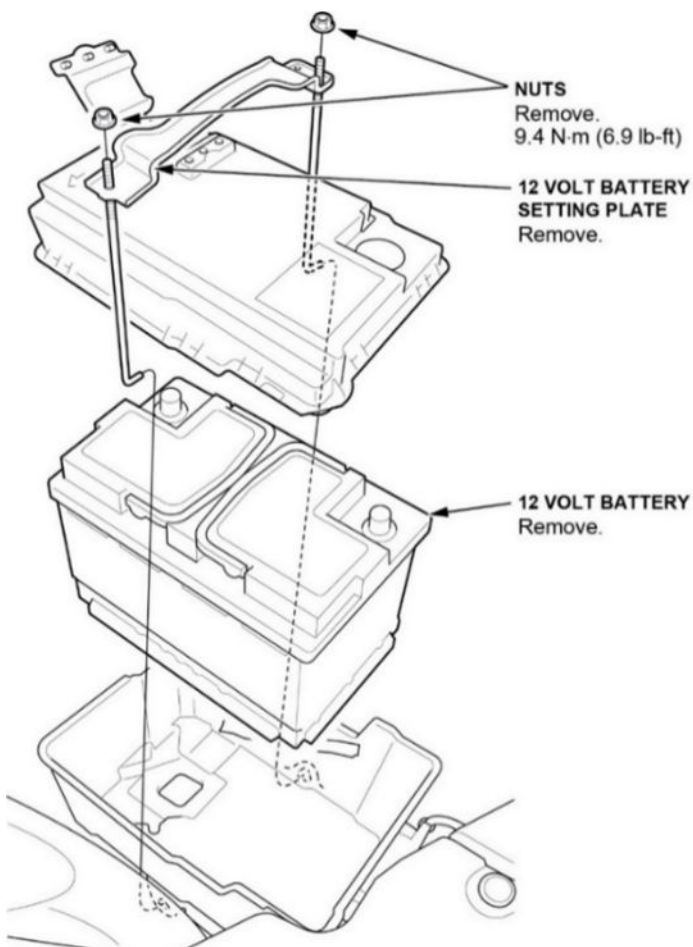

7. Remove the air cleaner.

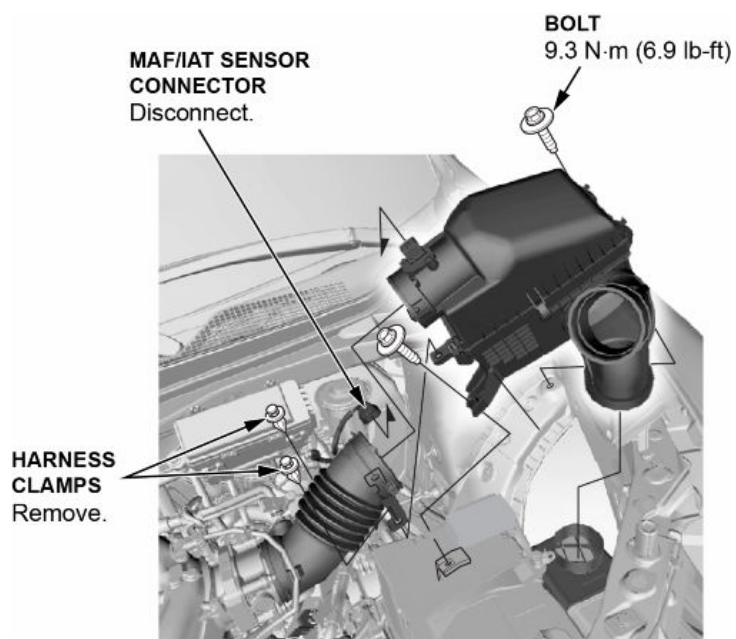

8. Disconnect the connector, then remove the harness holder.

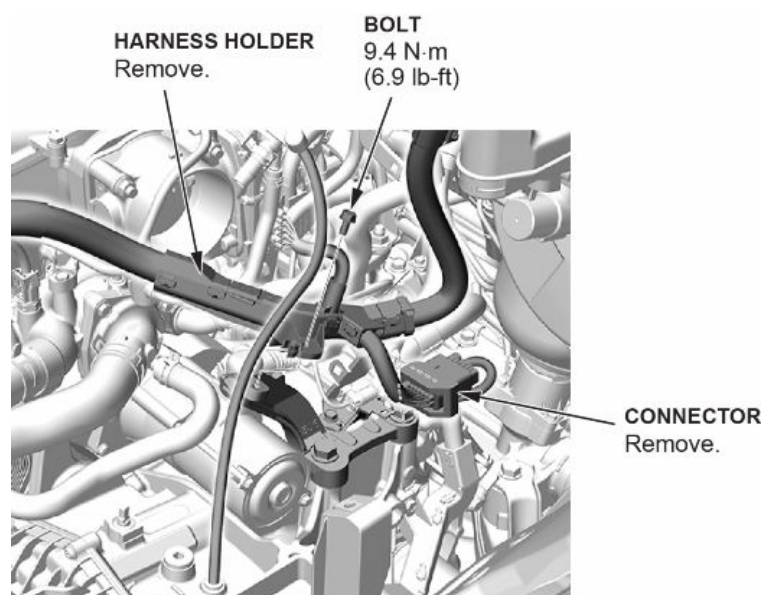

9. Remove the skid block.

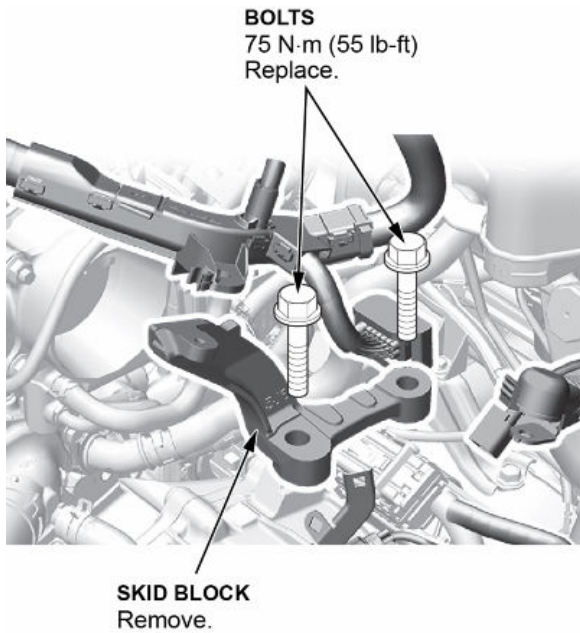

10. Disconnect the positive starter cable and connector, remove the harness connector and clamps, and then remove the starter.

NOTE: Make sure the crimped side of the ring terminal faces away from the starter when you connect the positive starter cable.

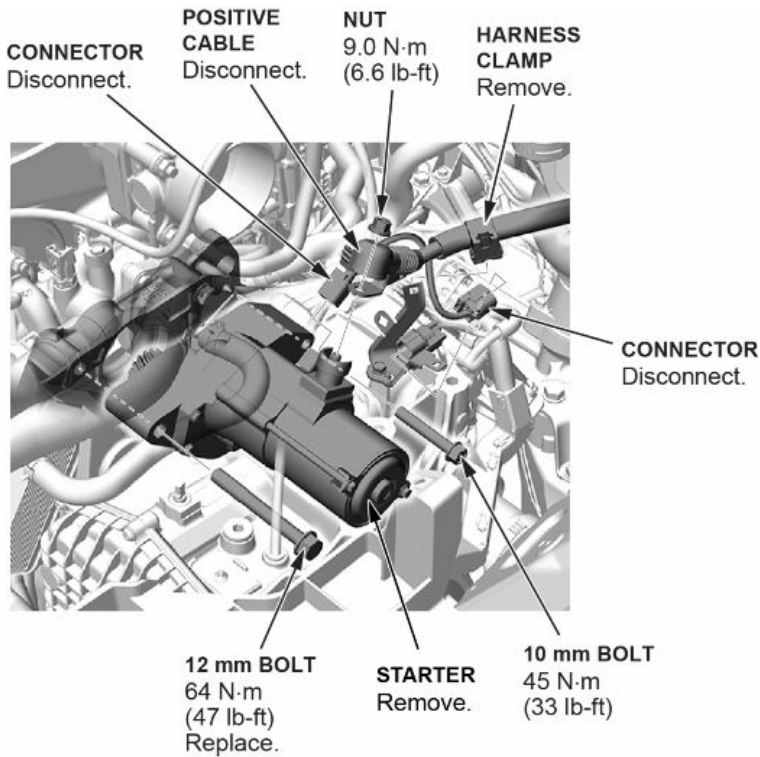

11. Install the new starter assembly.

12. Install all remaining parts in the reverse order of removal

13. Replace starter cut relay 1 and starter cut relay 2.

14. Connect the HDS to the DLC.

NOTE: Make sure the HDS is loaded with the latest software version.

15. Turn the vehicle to the ON mode.

16. Select **IDLE STOP STARTER COUNTER CLEAR** in the ADJUSTMENT MENU with the HDS.

END