

Technical product information

| | |
|------------------------|--|
| Topic | Touch Screen Remote (TSR) is not operating (No display or functionality) |
| Market area | Russische Föderation (5RU),Australia E04 Bentley rest Asia and Australia (6E04),China 796 VW Import Comp. Ltd (Vico), Beijing (6796),Germany E02 Bentley rest Europe (6E02),Japan E03 Bentley Japan (6E03),Korea, (South) E08 Bentley South Korea (6E08),United Arab Emirates E06 Bentley Middle East and Africa (6E06),United Kingdom E01 Bentley UK (6E01),United States E05 Bentley USA and rest America (6E05) |
| Brand | Bentley |
| Transaction No. | 2069551/1 |
| Level | EH |
| Status | Approval |
| Release date | |

New customer code

| Object of complaint | Complaint type | Position |
|--|--------------------------------------|----------|
| information, navigation, communication, entertainment -> infotainment sys. control using buttons, control panel, display panel | functionality | |
| information, navigation, communication, entertainment -> radio, navigation, MMI, hard drive device functions -> switch device/MMI on/off -> switch device/MMI on/off by remote control | functionality -> cannot be turned on | |
| information, navigation, communication, entertainment -> audio, video, television -> rear-seat entertainment system remote control | component / consumables -> missing | |

Vehicle data

Bentayga Series and New Flying Spur

Sales types

| Type | MY | Brand | Designation | Engine code | Gearbox code | Final drive code |
|------|------|-------|-------------|-------------|--------------|------------------|
| 4V1* | 2021 | E | | * | * | * |
| 4V1* | 2022 | E | | * | * | * |
| 4V1* | 2023 | E | | * | * | * |
| ZG2* | 2020 | E | | * | * | * |
| ZG2* | 2021 | E | | * | * | * |
| ZG2* | 2022 | E | | * | * | * |
| ZG2* | 2023 | E | | * | * | * |
| ZV1* | 2023 | E | | * | * | * |

Documents

| Document name |
|---------------|
| master.xml |

Touch Screen Remote (TSR) is not operating (No display or functionality)

Customer statement / workshop findings

- Referring to Figure 1 - The Touch Screen Remote (TSR) is not operating (No display or functionality)

! NOTICE

The issue described is evident regardless if the screen is located within the TSR cradle or not



Figure 1

Technical background

In the event the symptoms described are evident, please follow the instructions within the Measure section

! NOTICE

NOTE: The operative must first check and confirm that transport mode is not activated as the TSR will not function if transport mode is activated

Production change

-

Measure

! CAUTION

The electronic lock activates charging pins that locate into the side of the remote control

If battery failure of the remote control occurs whilst docked in the charging station DO NOT attempt to use force to remove the remote control from the charging station, the operative should conduct the following instruction to release the TSR and conduct the reset procedure

- 1) Referring to Rep.Gr 27 - Connect a suitable battery charger
- 2) Using ODIS - Eject the TSR from the cradle as follows:

- To navigate to the required data on the Vehicle tester - Navigate to - Service work
- Select 27 - TSR cradle unlock (Rep.Gr.90)
- Run the test

HINT: The remote control will then unlock and be motorised outwards from the charging station

- With the ignition switched on, use a suitable tool to momentarily press the reset switch located on the top edge of the TSR (Figure 2)

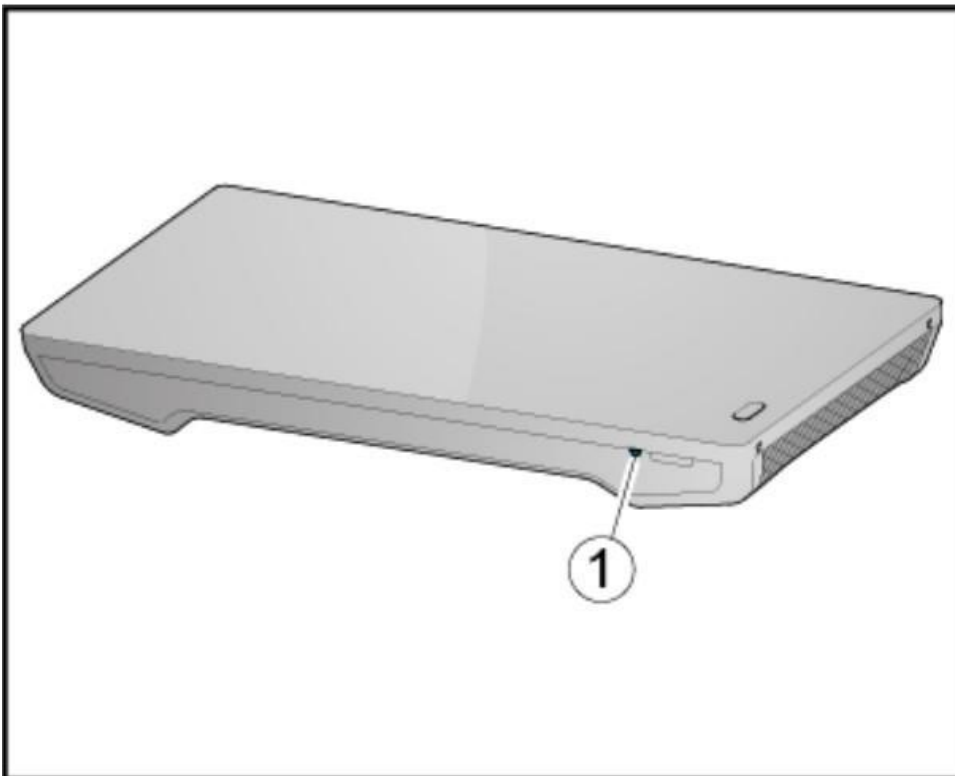

Figure 2

- Check the functionality of the TSR

NOTE: In the event the TSR is fully operational no further action is required

However



In the event the TSR is not fully operational, please raise a DISS query and await feedback before conducting any further work

Do Not replace the TSR without authorisation

Warranty accounting instructions

Time to conduct the TSR reset procedure

Warranty type 110 or 910

Damage service number 91 10

Damage code 00 40

Labour

Labour operation code 01 50 00 00

Time As per the ODIS log (Must not exceed 10 time units)