



# SERVICE ACTION

Global Service Action  
Number: N750

Changes are highlighted in blue

<b>Subject:</b>  <b>Front shock absorber incorrectly installed</b>	Publication No.: N750
	Model: Range Rover (LK)
	Model Year: 2023
	Model: Range Rover Sport (L1)
	Model Year: 2023
	Date of Issue: 22 February 2023
	Expiry Date: 28 February 2025

<b>To:</b>	All National Sales Companies (NSCs), importers, retailers and authorized repairers.
<b>For the Attention of:</b>	The approved Jaguar Land Rover (JLR) retailer/authorized repairer.
<b>Important:</b>	<p>NOTE: The information in this campaign is intended for use by professional technicians. If you are not a JLR retailer/authorized repairer, do not assume that a condition described affects a specific vehicle. Contact an authorized JLR retailer/authorized repairer to determine if this campaign applies to a specific vehicle.</p> <p>This campaign has been issued to provide the relevant repair instructions, parts and warranty information. This campaign is valid for two years only. Repairs must be completed prior to the expiry date at the top of this campaign.</p>

## FOR THE ATTENTION OF ALL:

### DESCRIPTION OF ISSUE

A potential concern has been identified on specific vehicles within the above vehicle range.

On certain 2023 model year Range Rover and Range Rover Sport vehicles the front left shock absorber may not be fully installed into the yoke.

### ACTION TO BE TAKEN

At the next opportunity, you are requested to repair the vehicle.

Following procedures appropriate to your market and as required by local legislation, owners of affected vehicles should be contacted requesting that the owner contact their nearest retailer/authorized repairer as soon as possible to arrange for the repair to be completed. The National Sales Companies (NSCs), Importer, Regional Office or Government agency will contact the customers. If you have any questions about this process, please contact your NSC/Importer or Regional Office for more information.

Check the JLR Warranty Portal to make sure affected vehicles are correctly identified prior to starting this campaign. The Warranty Portal will be updated to reflect only those vehicles affected.

An owner may indicate that a repair has already been completed for this concern, in which case the full cost of the repair should be reimbursed. Refer to the warranty section of this campaign for details of the Customer Reimbursement and Related Damage Process. At the time of confirming a booking for a vehicle repair, make sure you check the Warranty Portal to confirm if there are any other outstanding campaigns, to make sure the correct parts are available and adequate workshop time is allocated for repairs to be completed in one visit.

### FOR THE ATTENTION OF NORTH AMERICAN TERRITORIES ONLY:

Visit the British Brands Sales Suite (BBSS) website for a list of affected vehicles at your retailer/authorized repairer. Unsold vehicles must be repaired prior to handover of the vehicle for retail sale.

Yours faithfully

Steve Oldham

Global Customer Care Quality Director

# SERVICE INSTRUCTION - N750

## Parts Information

The parts below should be ordered through [Jaguar Land Rover \(JLR\)](#) in the normal manner.

Description	Model	Part Number	Qty	% Of Vehicles Requiring This Part*
Yoke to shock absorber - Nut	All	FY112056	1	15%
Front stabilizer link - Nut	Range Rover - With electric dynamic response Range Rover Sport - With electric dynamic response Range Rover - Without electric dynamic response	LR152798	1	15%
Front stabilizer link - Bolt	Range Rover - With electric dynamic response Range Rover Sport - With electric dynamic response	FC114206	1	15%
Front stabilizer link - Nut	Range Rover Sport - Without electric dynamic response	FY114056	1	15%

\* When ordering parts, order no more than the expected percentage failure rate of parts identified

## SROs

Description	SRO	Time
N750 - Inspect front left shock absorber - No further action	05.10.20	0.2
N750 - Inspect front left shock absorber - Install shock absorber	05.10.50	0.5
Drive in/drive out	02.02.02	0.2

### NOTE:

Repair procedures are under constant review, and therefore times are subject to change; those quoted here must be taken as guidance only. Always refer to TOPIx to obtain the latest repair time.

## Warranty Information

Warranty claims should be submitted quoting program code N750 with the relevant option code from the table below. As option codes are used there is no requirement for you to enter SROs or parts, these are included for information only.

Program Code	Option	Model	Description	SRO	Time	Part Number	Qty
N750	A	All	N750 - Inspect front left shock absorber - No further action	05.10.20	0.2	N/A	N/A
N750	B	All	N750 - Inspect front left shock absorber - No further action Drive in/drive out	05.10.20 02.02.02	0.2 0.2	N/A	N/A
N750	C	Range Rover - With electric dynamic response Range Rover Sport - With electric dynamic response	N750 - Inspect front left shock absorber - Install shock absorber	05.10.50	0.5	FY112056 LR152798 FC114206	1 1 1
N750	D	Range Rover - With electric dynamic response Range Rover Sport - With electric dynamic response	N750 - Inspect front left shock absorber - Install shock absorber Drive in/drive out	05.10.50 02.02.02	0.5 0.2	FY112056 LR152798 FC114206	1 1 1
N750	E	Range Rover Sport - Without electric dynamic response	N750 - Inspect front left shock absorber - Install shock absorber	05.10.50	0.5	FY112056 FY114056	1 1
N750	F	Range Rover Sport - Without electric dynamic response	N750 - Inspect front left shock absorber - Install shock absorber Drive in/drive out	05.10.50 02.02.02	0.5 0.2	FY112056 FY114056	1 1
N750	G	Range Rover - Without electric dynamic response	N750 - Inspect front left shock absorber - Install shock absorber	05.10.50	0.5	FY112056 LR152798	1 1

Program Code	Option	Model	Description	SRO	Time	Part Number	Qty
N750	H	Range Rover - Without electric dynamic response	N750 - Inspect front left shock absorber - Install shock absorber Drive in/drive out	05.10.50 02.02.02	0.5 0.2	FY112056 LR152798	1 1

 **NOTE:**

The option that contains the drive in/drive out allowance may only be claimed when the vehicle has been brought back into the workshop for this action alone to be undertaken.

Warranty claims should be submitted in accordance with the current [JLR](#) Global Warranty Manual, and its amendments, unless stated otherwise in this bulletin.

## Customer Reimbursement and Related Damage Process

 **NOTE:**

If there is a requirement to claim for related/consequential damage or customer reimbursement, refer to the related instruction that can be found in TOPIx (in the Search box, search for 'Related Damage Claim' and open the related bulletin link).

Table of Contents
<a href="#">REMOVAL AND INSTALLATION: SERVICE INSPECTION</a>
<a href="#">REMOVAL AND INSTALLATION: SERVICE INSTRUCTION</a>

## SERVICE INSPECTION

 **NOTES:**

- Some components shown removed for clarity.
- Some variation in the illustrations may occur, but the essential information is always correct.

1. Raise the vehicle on a suitable 2 post lift (see TOPIx Workshop Manual section 100-02: Jacking and Lifting - Description and Operation - Jacking and Lifting).

2. Visually inspect the installed position of the front left shock absorber into the yolk.

If the front left shock absorber **is** fully installed in the yolk, as shown in the image with a green '✓', no further action is required. Lower the vehicle and release.

If the front left shock absorber **is not** fully installed in the yolk, as shown in the image with a red 'X', continue to the SERVICE INSTRUCTION.

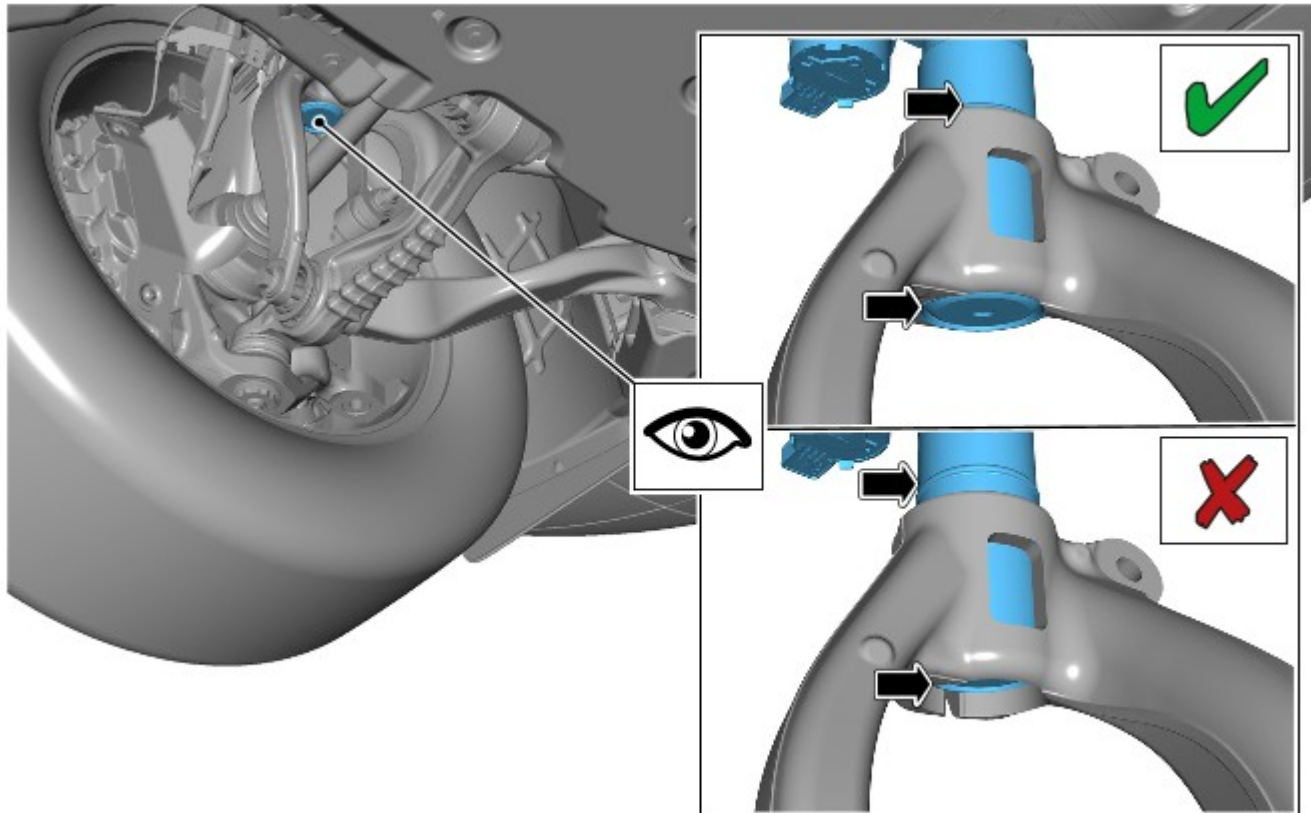

E324428

## SERVICE INSTRUCTION

### NOTES:

- Some components shown removed for clarity.
- Some variation in the illustrations may occur, but the essential information is always correct.

1. Remove the front left wheel and tire (see TOPlx Workshop Manual section 204-04: Wheels and Tires - Removal and Installation - Wheel and Tire).

2.

**CAUTION:**

The stabilizer bar link nut and bolt must not be reused.

**NOTES:**

- This step only applies to vehicles that are installed with electric dynamic response.
- Note the orientation of the nut and bolt prior to removal.

2. Reposition the front stabilizer link away from the yoke.

Remove and discard the nut and bolt.

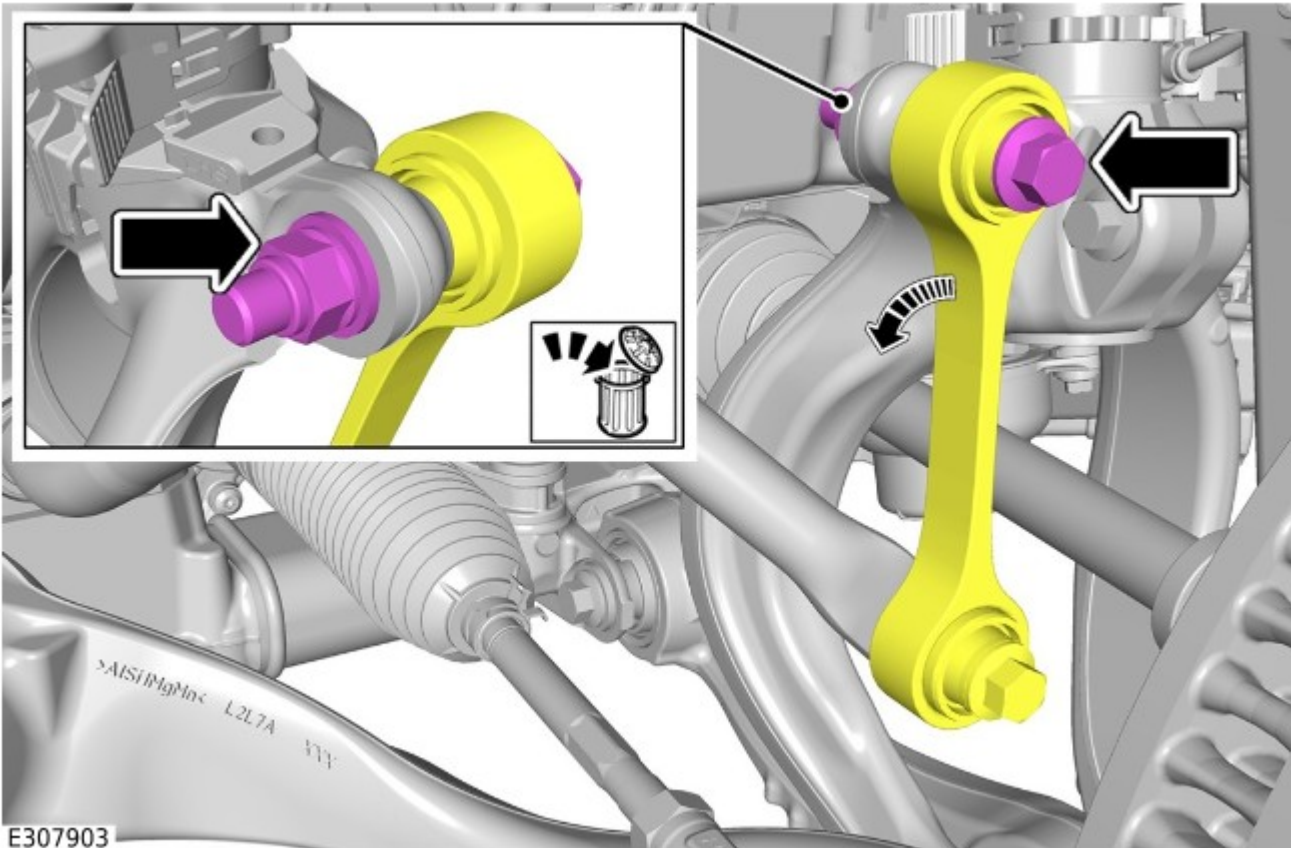

3.

 **CAUTIONS:**

- Use a suitable tool to prevent the ball joint rotating.
- The front stabilizer link ball joints can be damaged by excessive movement. Do not over articulate the ball joints. Failure to follow this instruction may damage the component.

 **NOTE:**

This step only applies to vehicles that are installed without electric dynamic response.

3. Reposition the front stabilizer link away from the yoke.

Remove and discard the nut.

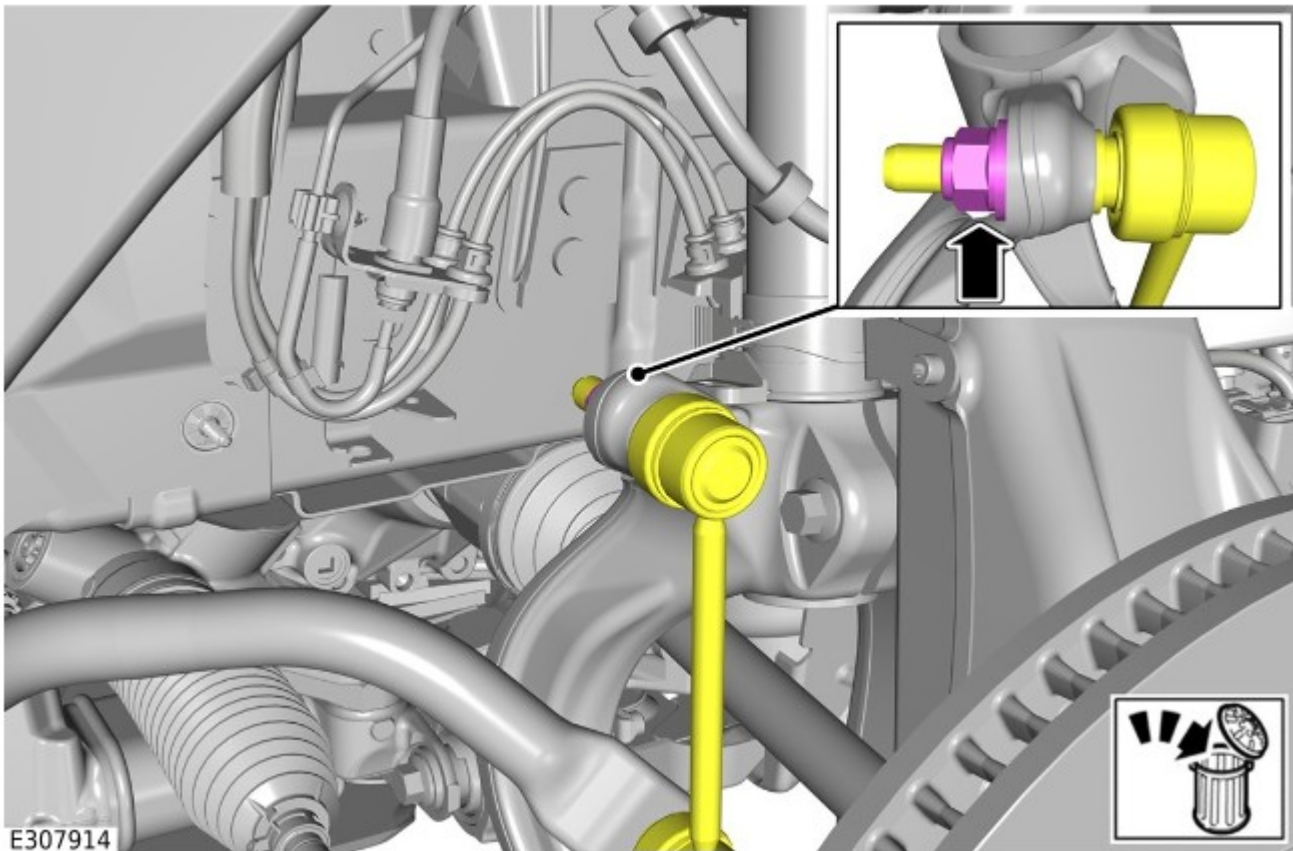

4.

**CAUTION:**

The yoke to front shock absorber nut must not be reused.

4. Remove the yoke to front shock absorber nut and bolt and discard the nut only.

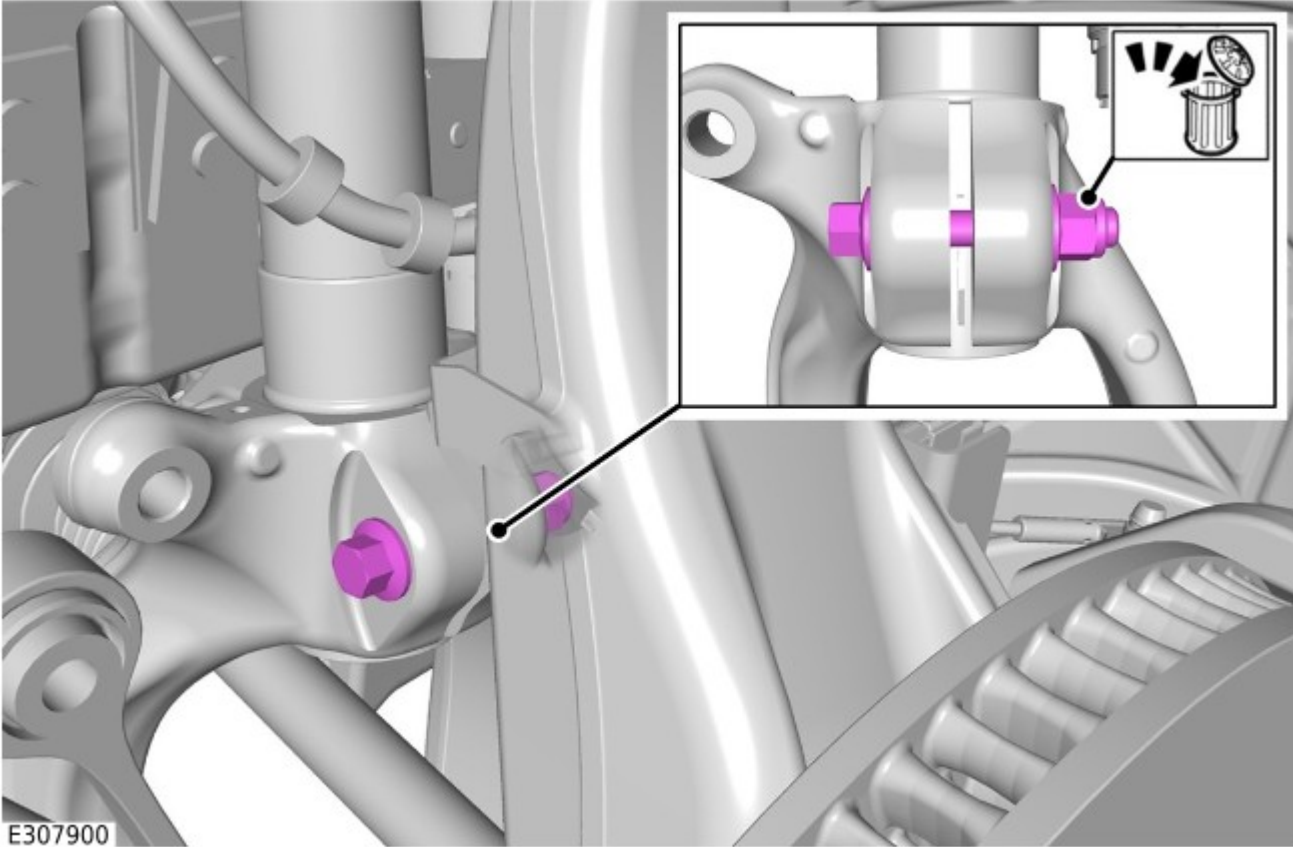

5. Use special tool JLR-204-877 to release the yoke from the front shock absorber.

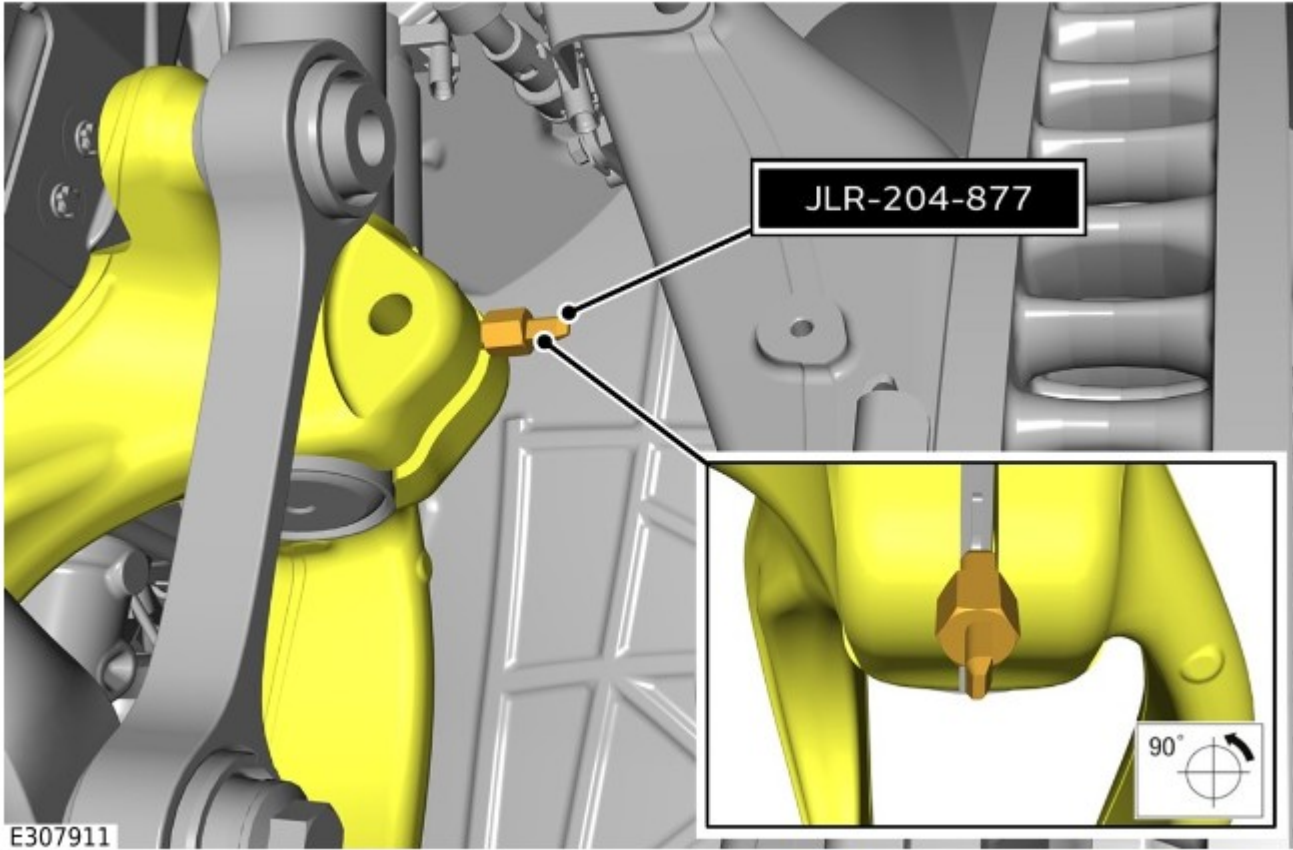

6. Use a suitable stand, raise the front left suspension assembly.

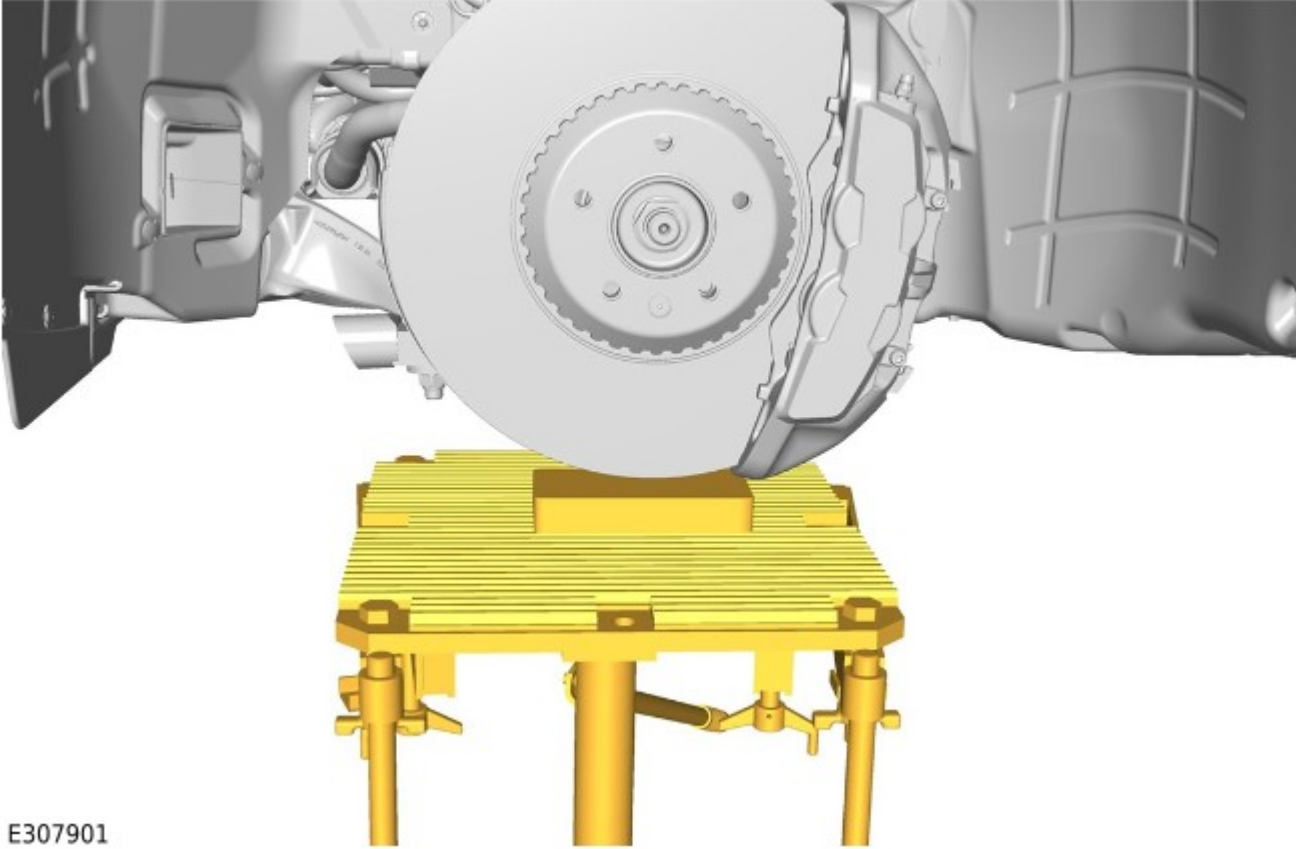

E307901

7. When the shock absorber is fully installed in the yolk, as shown in the image with a green '✓', remove special tool JLR-204-877.

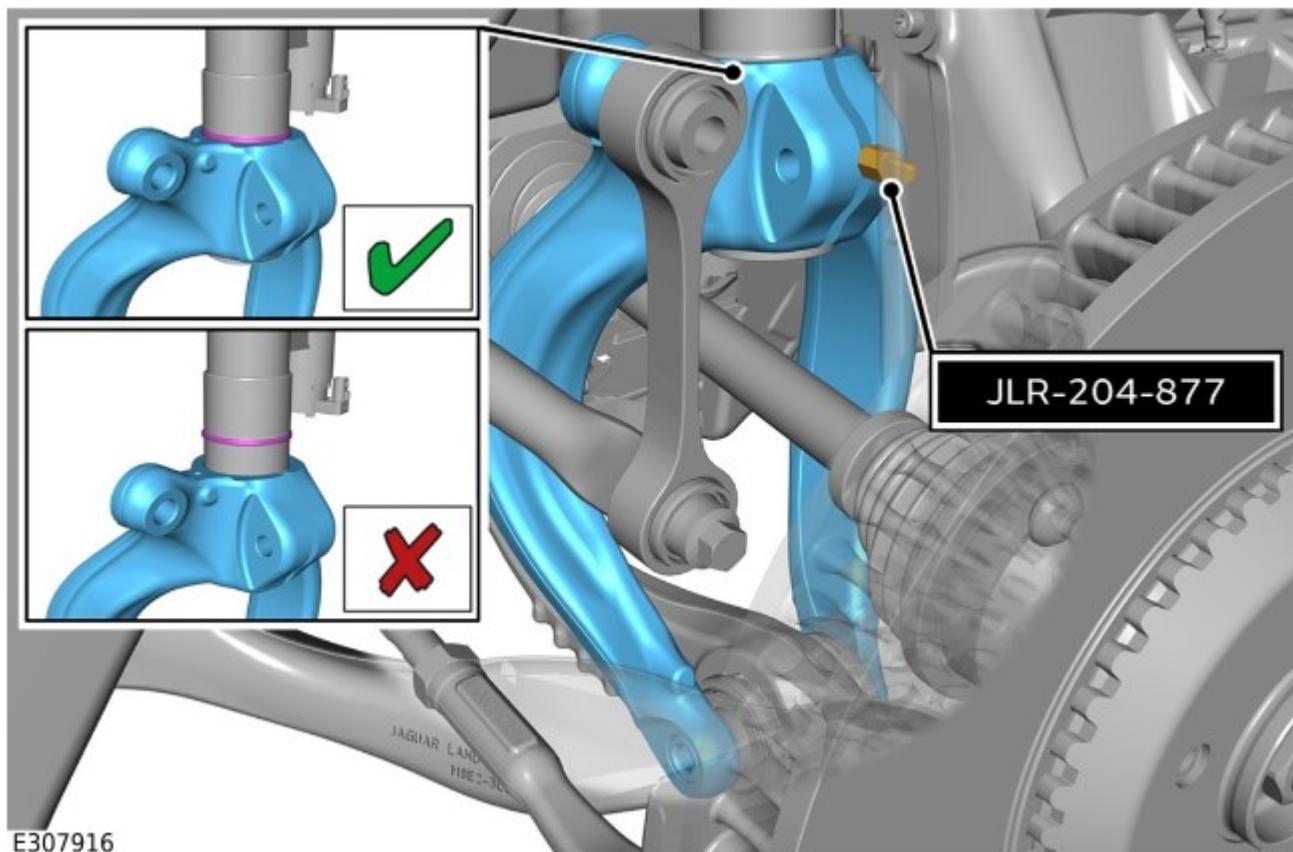

8. Install the original yoke to front shock absorber bolt with a new nut but do not tighten at this stage.

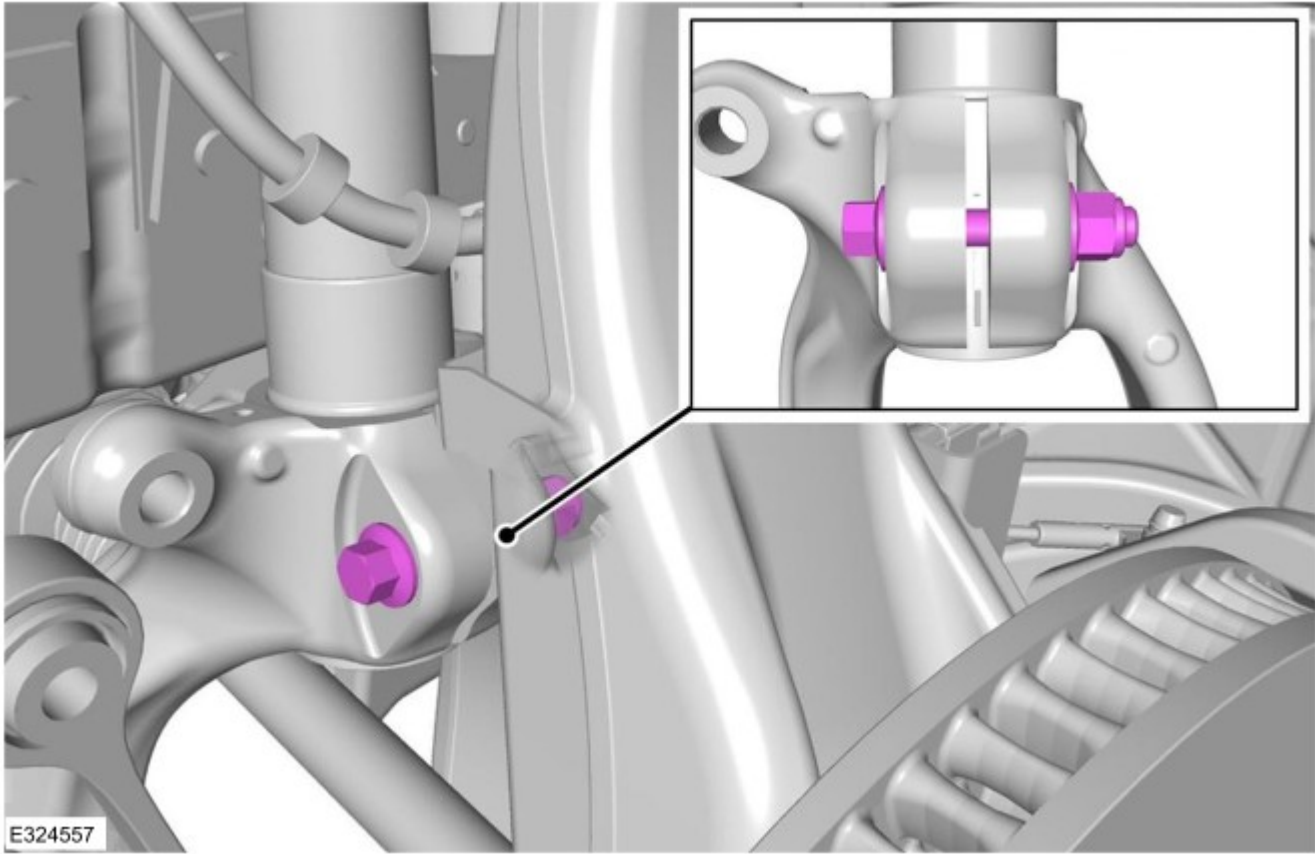

E324557

9.

 NOTE:

This step only applies to vehicles that are installed with electric dynamic response.

9. Secure the front stabilizer bar link to the yoke.

Install the new nut and bolt but do not tighten at this stage.

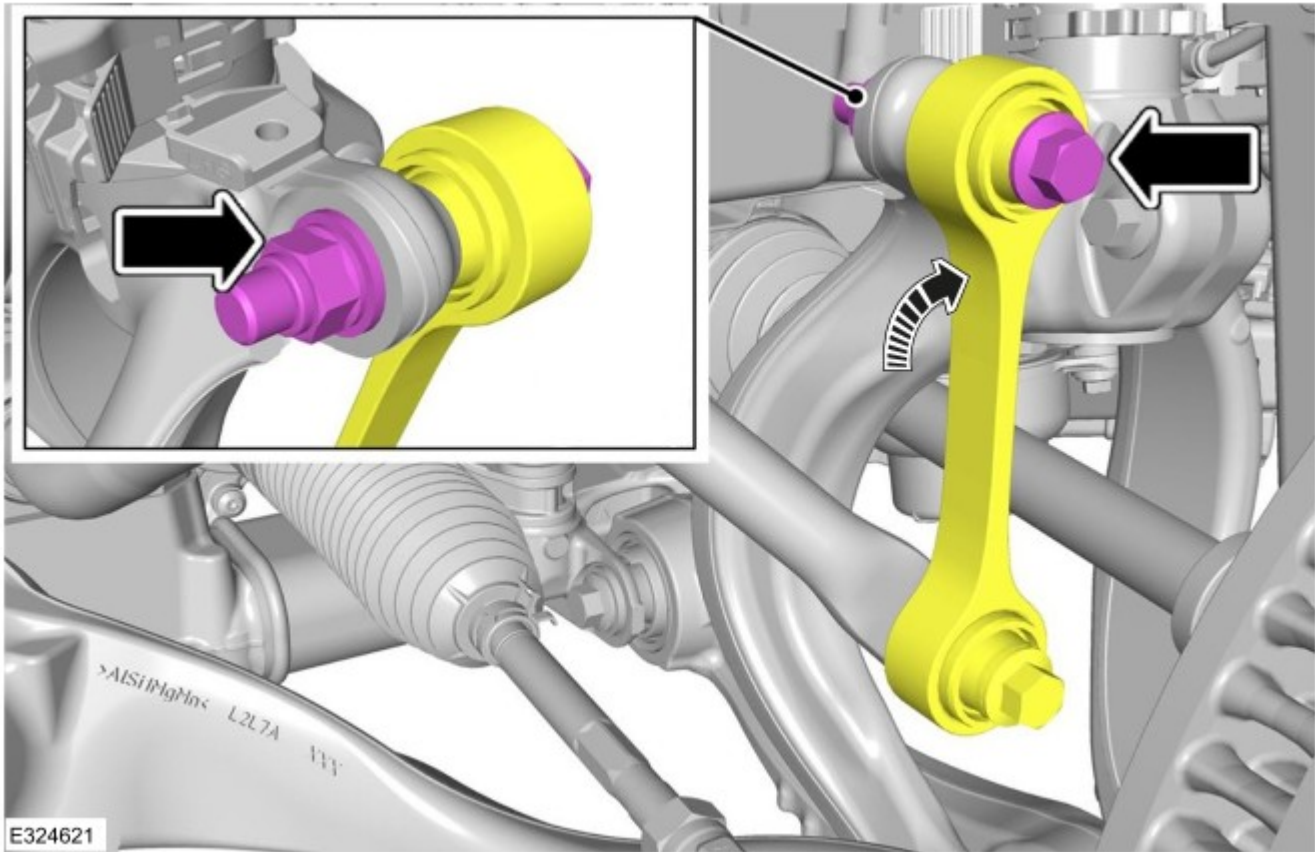

10.

 NOTE:

This step only applies to vehicles that are installed without electric dynamic response.

10. Secure the front stabilizer bar link to the yoke.

Install the new nut but do not tighten at this stage.

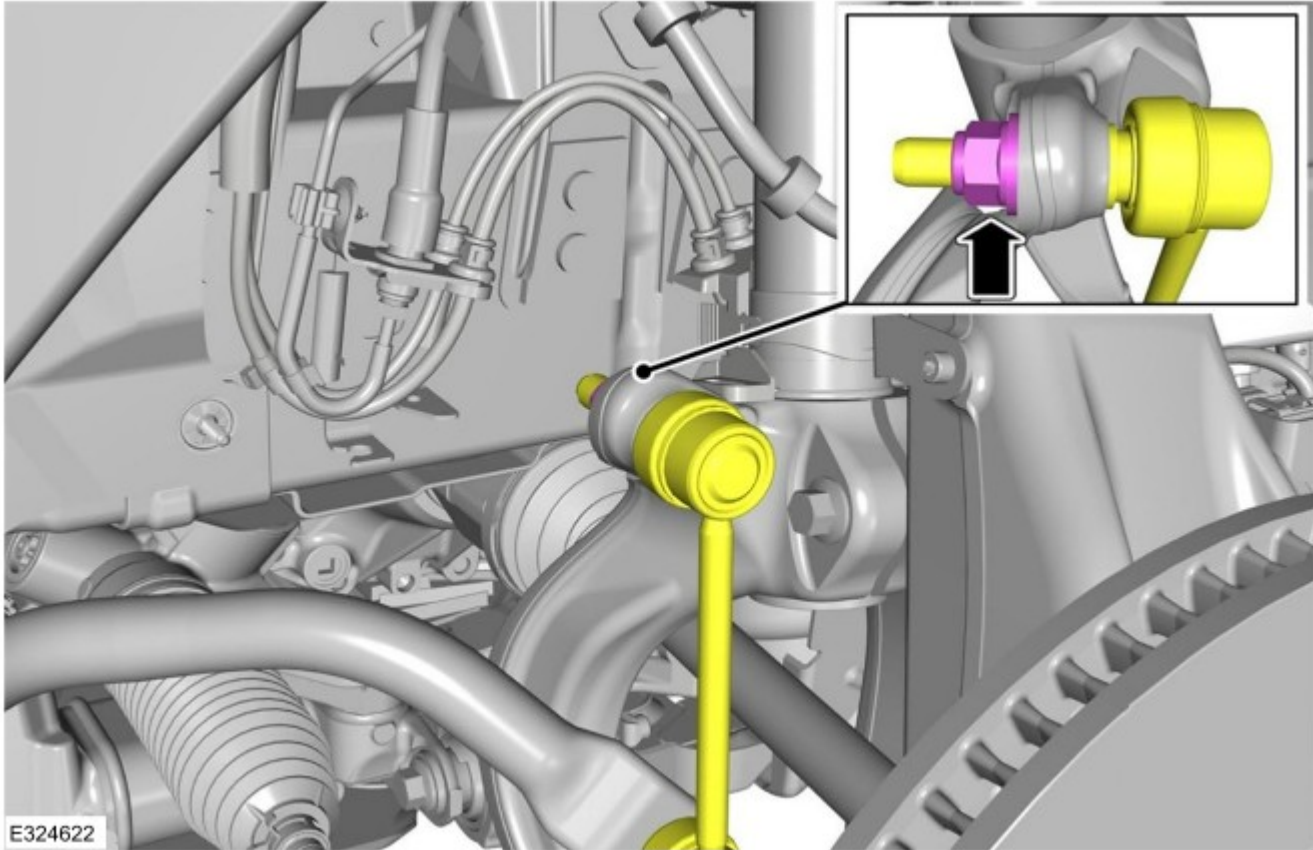

11. Install 3 wheel bolts and install special tools 204-557B and JLR-204-557B-01.

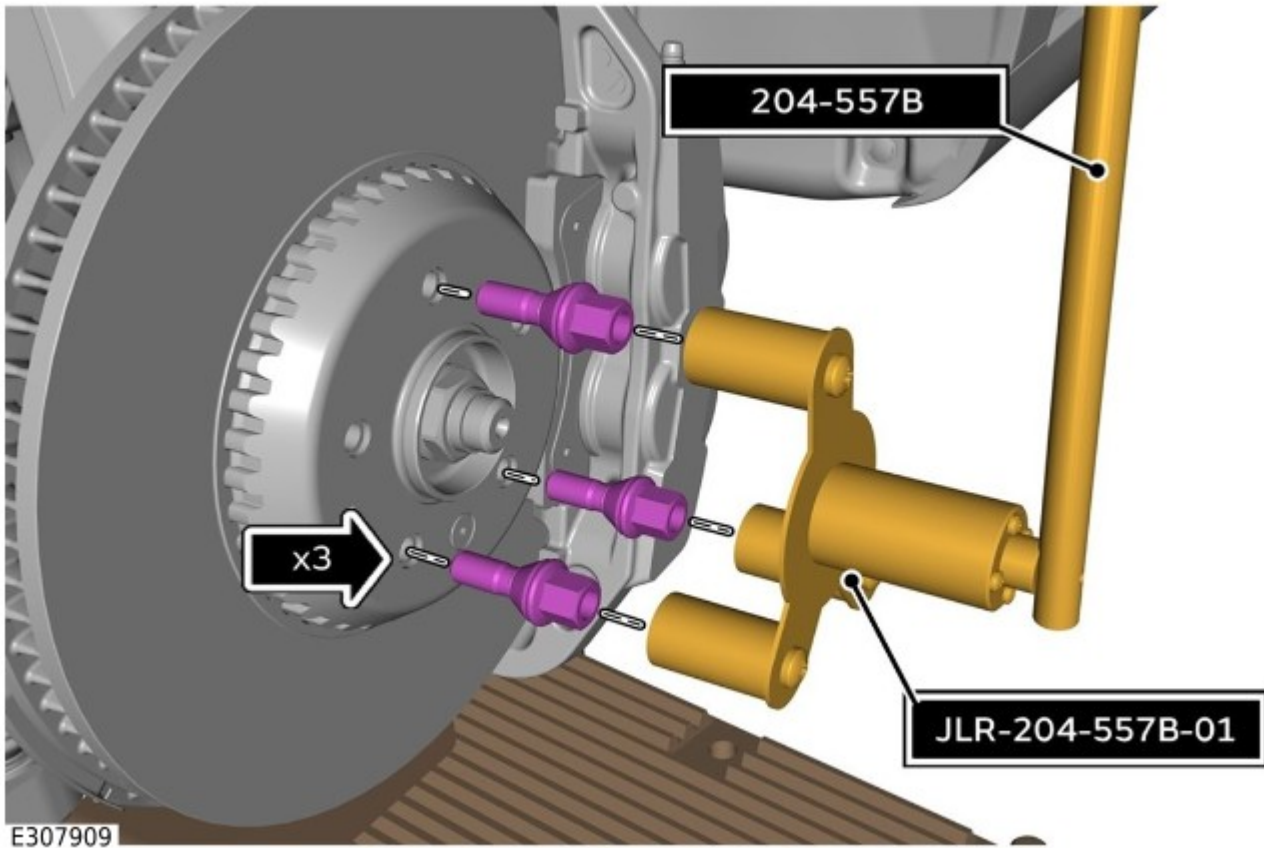

12. Use the stand to reposition the suspension assembly to normal ride height - 487 mm.

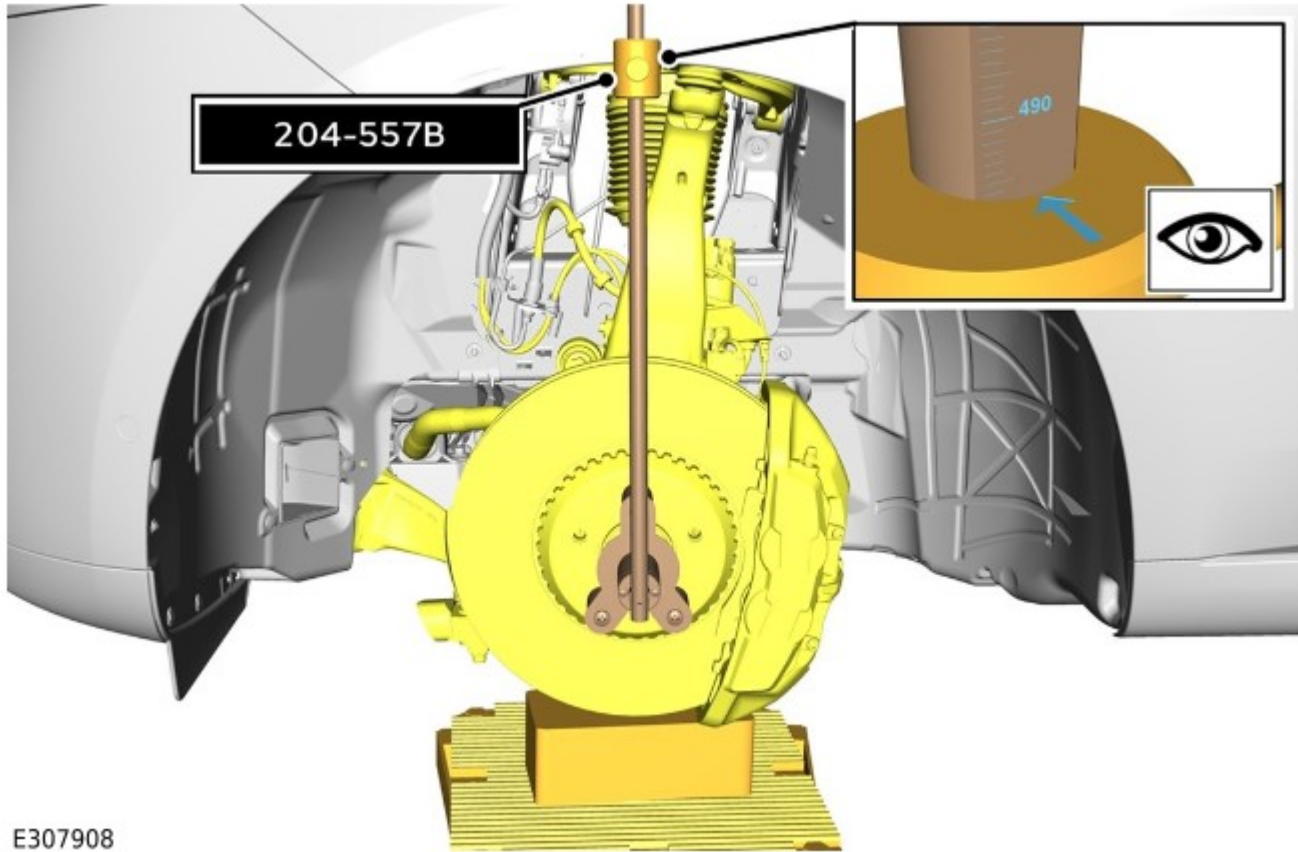

E307908

13. Fully tighten the yolk to shock absorber fixing.

Torque: **95 Nm**

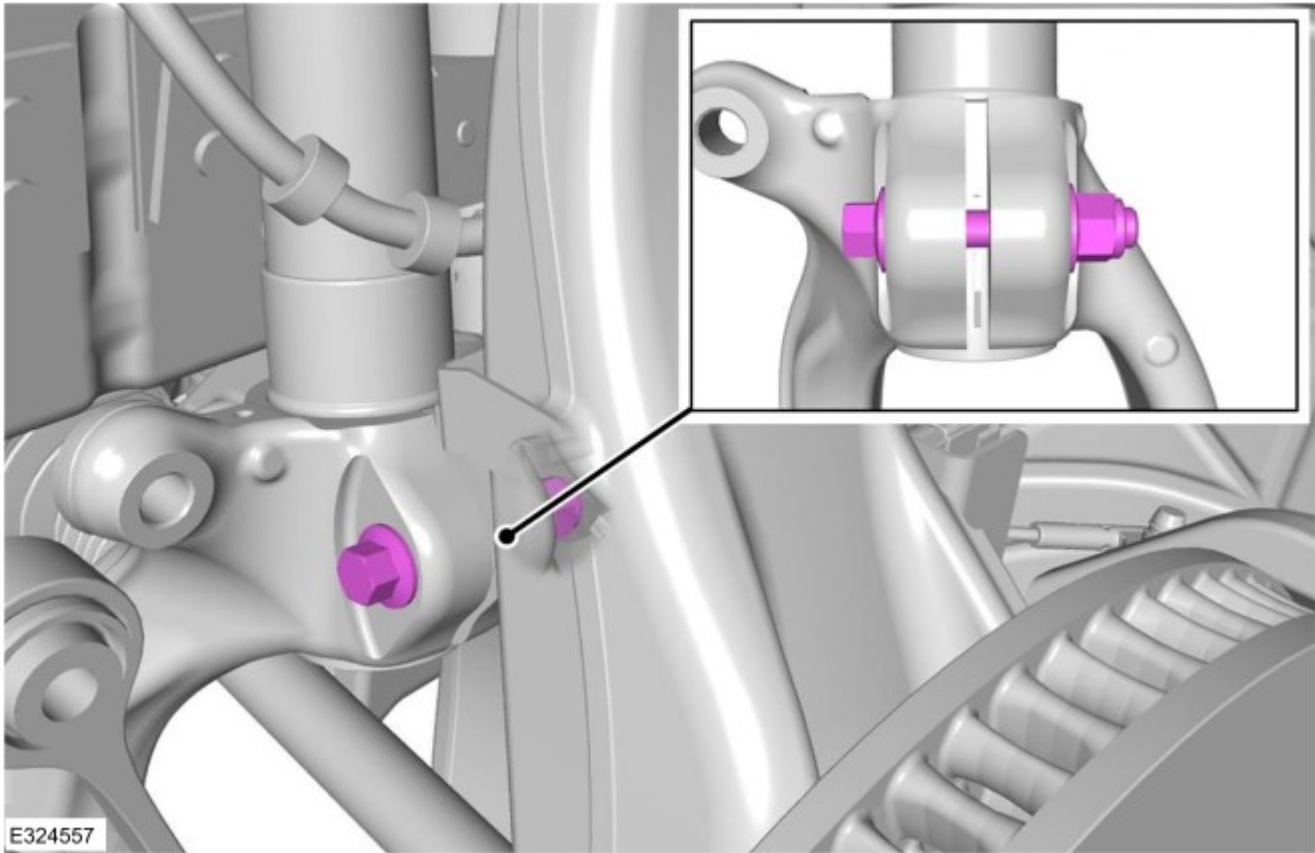

14.

 NOTE:

This step only applies to vehicles that are installed with electric dynamic response.

14. Fully tighten the front stabilizer link fixing.

Stage 1: 70 Nm

Stage 2: 240°

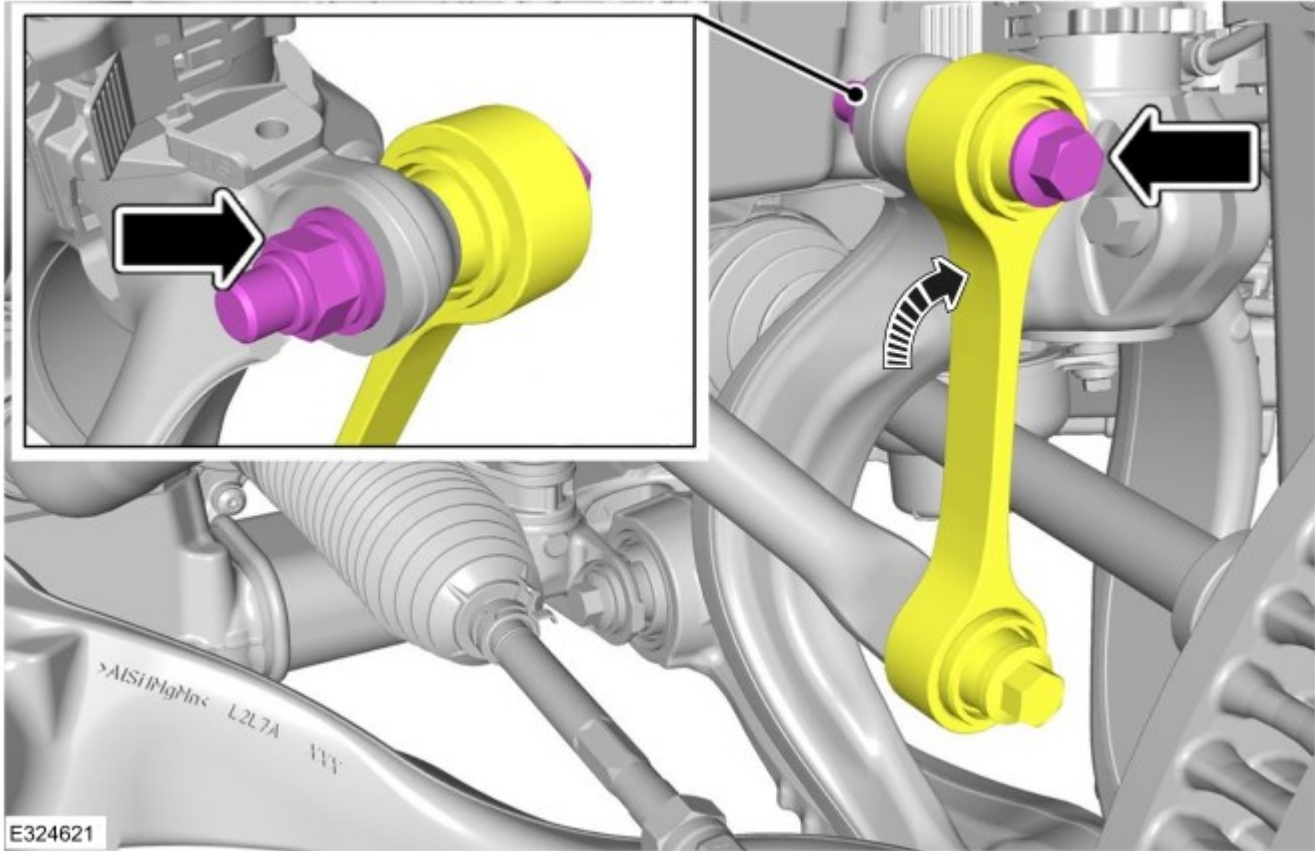

15.

 NOTE:

This step only applies to vehicles that are installed without electric dynamic response.

15. Fully tighten the front stabilizer link fixing.

Torque: **185 Nm**

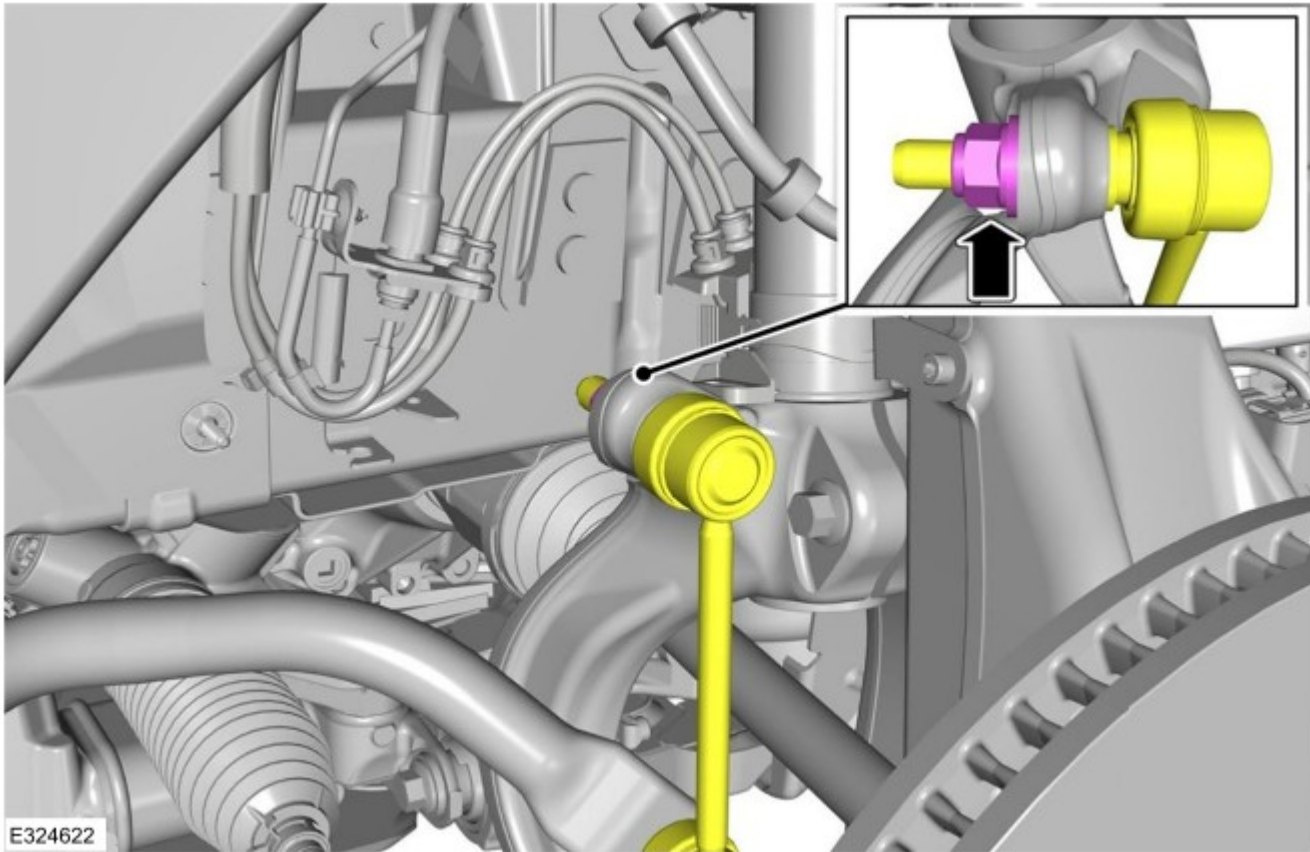

16. Lower the front left suspension assembly and remove the stand.

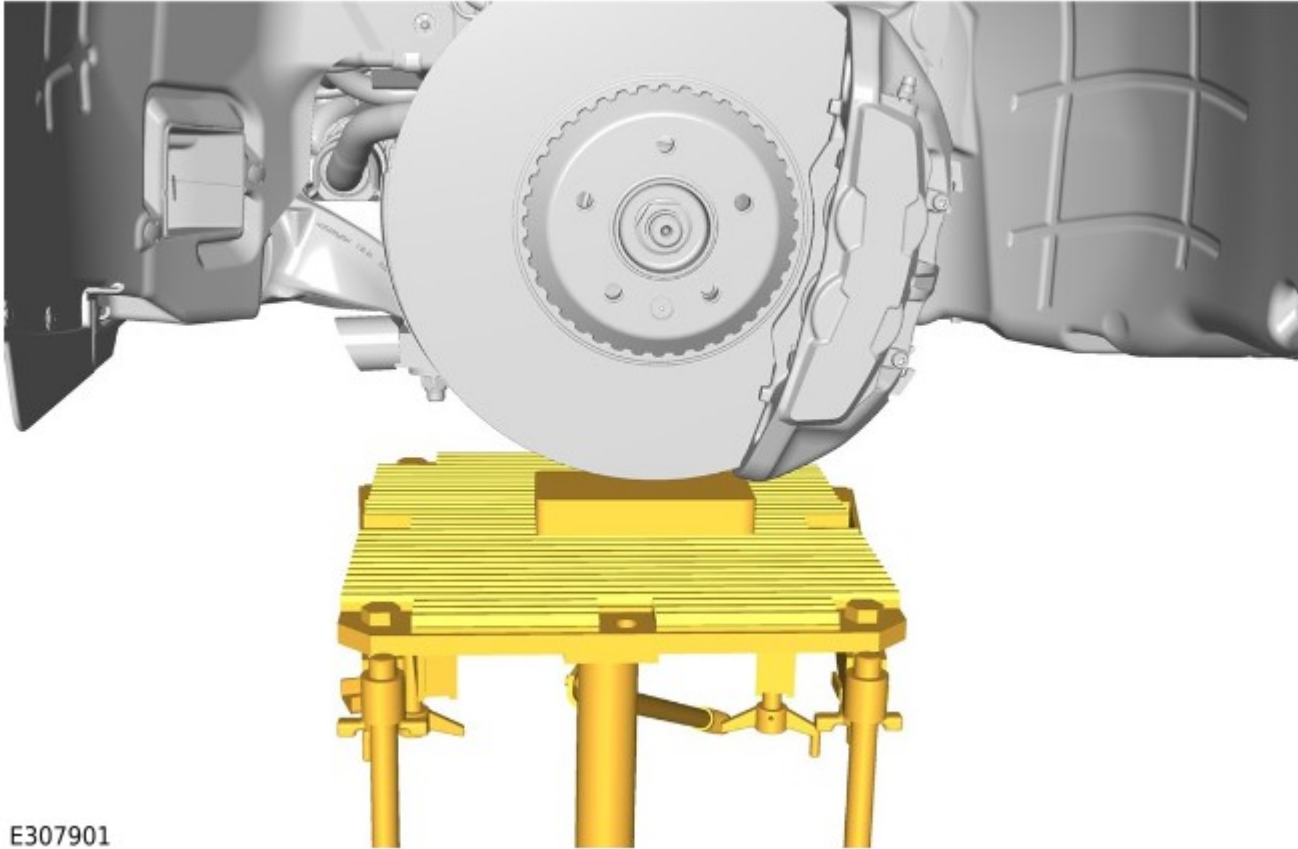

E307901

17. Install the front left wheel and tire (see TOPIx Workshop Manual section 204-04: Wheels and Tires - Removal and Installation - Wheel and Tire).

18. Lower the vehicle and release.

**SAMPLE CUSTOMER LETTER - FOR INFORMATION ONLY**

Name  
Address line 1  
Address line 2  
Address line 3  
Post Code

Vehicle Identification Number (VIN):  
Registration Number:  
Program Number: N750

Date: month/year

**An important message for owners of Range Rover and Range Rover Sport vehicles**

Dear

We are providing a Customer Satisfaction Program free of charge to owners of certain 2023 Model Year Range Rover and Range Rover Sport vehicles.

**Why are we contacting you?**

We have found that the front left shock absorber may not be installed in the correct position. The air suspension will continue to self-level the vehicle, but off-road usage may cause damage to suspension components due to reduced damper range.

**What will your Jaguar Land Rover retailer/authorized repairer do?**

We will inspect the installation of the front left shock absorber and adjust if required. This will be done free of charge under the terms of this program.

**How long will it take?**

We will complete the work as quickly and efficiently as possible to minimize inconvenience to you. Your retailer or authorized repairer will advise how long they will need your vehicle when you make the booking.

**What we are asking you to do**

Call your preferred Jaguar Land Rover retailer/authorized repairer without delay. Quote your Vehicle Identification Number (VIN) (located at the beginning of this letter) and vehicle registration number, ask for a repair date for N750. If you do not have a retailer/authorized repairer, please access [www.landrover.co.uk](http://www.landrover.co.uk) or [www.landrover.com](http://www.landrover.com) for contact details.

If you have trouble getting your vehicle repaired promptly and free of charge, contact the retailer/authorized repairer Service Manager for assistance.

Thank you for attending to this important matter.

Yours sincerely

Head of Business