



Countries:
Availability: ISIS, Bus ISIS, FleetISIS, Body Builder, NotSIR
Major System: COOLING
Current Language: English
Other Languages: NONE
Viewed: 2531

Document ID: IK0900141
Revision: 9
Created: 3/19/2021
Last Modified: 2/23/2023
Author: George Mooney

[Less Info](#)

Hide Details

Coding Information

Copy Link 	Copy Relative Link 	Bookmark View My Bookmarks	Add to Favorites 	Print 	Provide Feedback 	Helpful 6	Not Helpful 0
----------------------	-------------------------------	--	-----------------------------	------------------	-----------------------------	-------------------------	-----------------------------

Title: Bus, Durastar & MV Air Compressor Inlet Hose Chaffing / Leaking

Applies To: Bus, Durastar & MV equipped w/Cummins ISB / B6.7

CHANGE LOG

Please refer to the change log text box below for recent changes to this article:

02/23/2023 - Changed author, updated part numbers and images
 05/17/2022- Updated article with new part number and images.
 11/17/2021- Responded to feedback via email and republished article.
 09/30/2021- Added bus platform
 08/31/2021- Updated article adding Durastar and previous CAC routing

DESCRIPTION

Navistar has identified that, in some circumstances, the Air Compressor Inlet Hose from the Charge Air Cooler (CAC) may chafe or leak during normal vehicle operation. The description and images below offer instructions on how to replace and properly route the new hose assembly.

SYMPTOM(s)

Diagnostic Trouble Code(s) & Dashboard Indicator Light(s):

DTC/Light	Description
SPN: 411 FMI: 2 (Cummins 1866)	EGR Differential Pressure - Data Erratic, Intermittent, or Incorrect
SPN: 102 FMI: 10 (Cummins 3361)	Intake Manifold Pressure - Abnormal rate of change
SPN: 3058 FMI: 18 (Cummins 3382)	EGR System - Data valid but below normal operating range
SPN: 3058 FMI: 10 (Cummins 3389)	EGR System - Abnormal rate of change

Customer Observations or Concerns:

- Air compressor inlet hose chaffed
- Turbo boost air leak at the air compressor inlet hose
- Check engine light

SPECIAL TOOL(s) / SOFTWARE

Tool Description	Tool Number	Comments	Instructions
N/A			

SERVICE PARTS INFORMATION

Kit Description	Part Number	Quantity	Notes
HOSE, AIR COMPRESSOR, (1BF) (#2 & 2a)	6132813C4	1	Only required if chafed or leaking <u>Do not use a worm clamp design, this can cut and damage the new hose.</u>
CLAMP, POWER STNG	3576743C1	2	
SWIVEL (#1)	3554554C1	1	Replace if missing
SADDLE (#3)	3553742C1	1	Replace if missing
SWIVEL (#4) (Installed after May 19')	4077219C1	1	Replace if missing
STRAP, CABLE LOCK	3626607C1		Use as required

Vehicles built between (5/31/2017 to 11/18/2019)

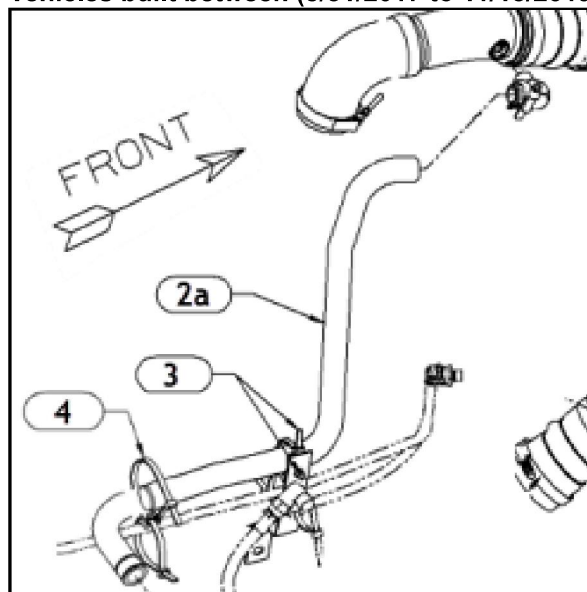

Bus, Durastar & MV (11/18/2019 to June 2022)

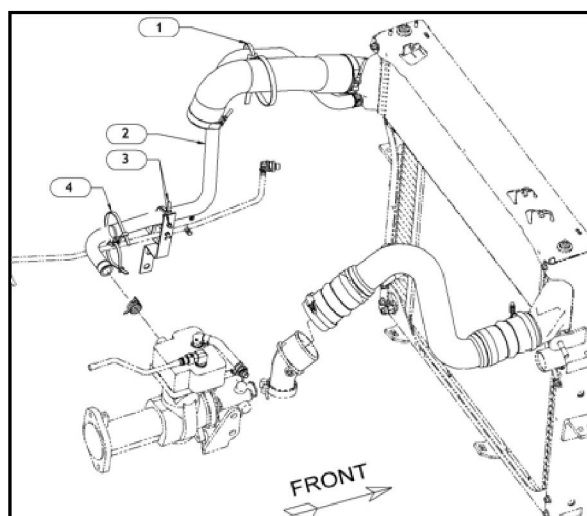



Figure 1: Updated hose PN 6132813C4 & material ID (1BF)



Figure 2: Zip tie alignment locations

DIAGNOSTIC STEP(s)

NOTE:

If an engine has experienced a failed air compressor hose and check engine light with active or inactive fault codes: 1866, 3361, 3382 and or 3389. Please refer to Cummins [Inspection & Cleaning Procedure Air Intake Connection](#) and [Service Bulletin 5579934](#) for further information. Proceed with hose replacement after cleaning and inspection has been completed.

NOTE:

If a hose is found to be chafed or leaking with no fault codes present proceed with hose replacement and routing steps listed below.

NOTE:

Reference Cummins Inspection & Cleaning of Air Intake Connection

1. Bring vehicle into shop and park on a flat surface.
2. Shift transmission into park or neutral, set parking brake, and install wheel chocks
3. Open the hood.
4. Remove charge air cooler hose (CAC), cut tie straps if needed.
5. Inspect air compressor inlet hose for chafing or leaks.
6. If chafing or leaks are found, replace hose.
7. Route and clip hose per instructions below.

REPAIR STEP(S)

Note:

Vehicles built between 5/31/2017 and 11/18/2019 will have the air compressor supply hose routed to the CAC piping per the images below.

- For use on vehicles built between 5/31/2017 - 11/18/2019 only
- Air compressor hose PN 6132813C4 must be modified per directions below

1. Verify routing and clipping as follows.



Figure 1: New CAC piping installed



Figure 2: Air Compressor Inlet Hose

Item 1: Air compressor inlet hose cut and installed

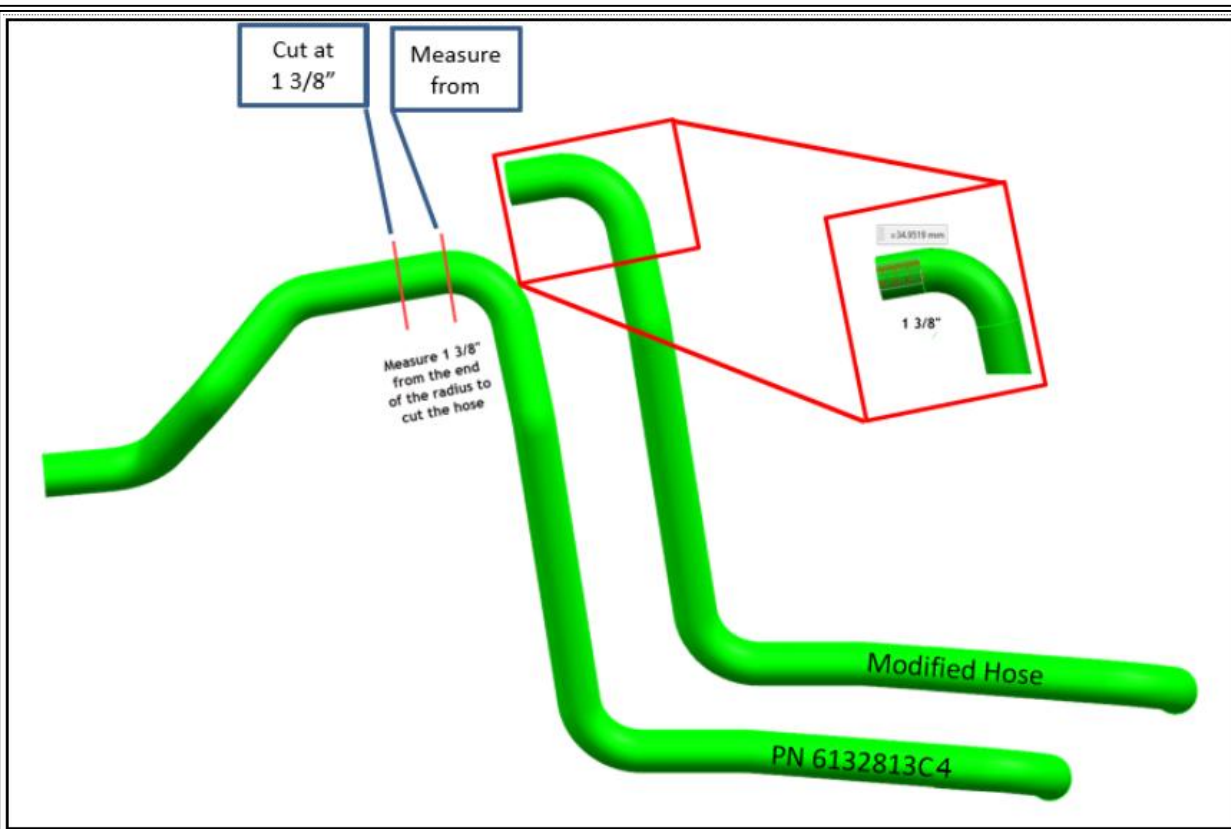

Figure 3: When modifying a 6132813C4 hose assembly measure 1 3/8\" from the end radius.

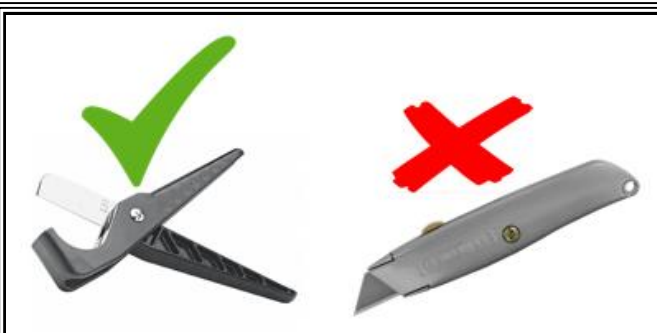

Figure 4: Use the proper tool to cut the hose assembly

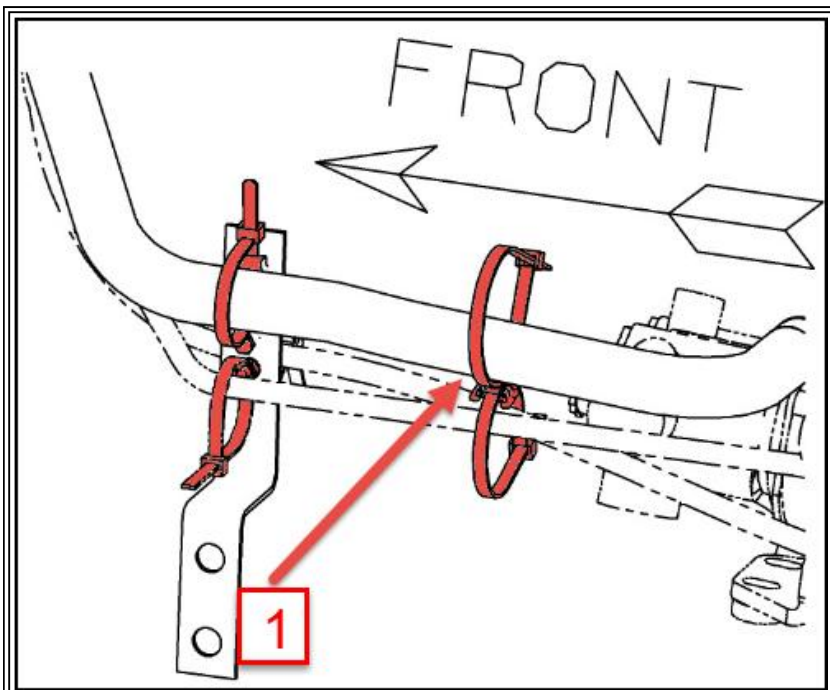

Figure 5: Air Compressor End Securement

Item 1: Ensure cable lock swivel PN 4077219C1 is installed between cable locks to allow for hose movement.

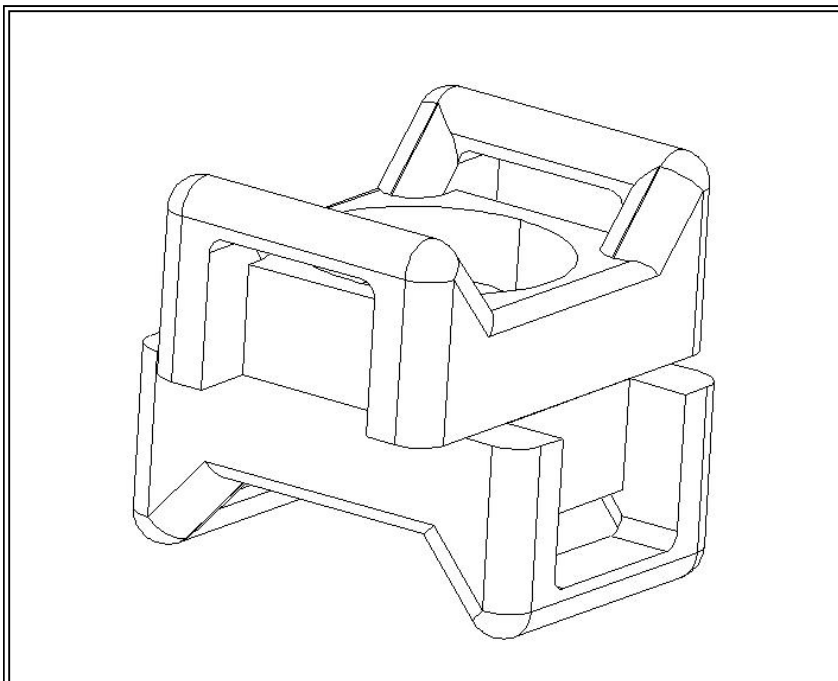

Figure 6: 4077219C1 - Cable Lock Swivel Guide

2. Start engine and check for leaks.
3. Close hood.
4. Remove wheel chocks.

REPAIR STEP(s)

Note:

Vehicles built after 11/18/2019 will have the air compressor supply hose routed back to the CAC. The CAC has been updated with a new design to include an internal snorkel.

NOTE:

Do not use the original clamps due to diameter difference of the updated hose.

Route and Clip Requirements: (Vehicles built after 11/18/2019 to current production)

1. Air Compressor Intake Hose clipping point on the CAC pipe shall be centered horizontally and securely fastened with a saddle & tie strap. (Figure 1)
2. Air Compressor Intake Hose clipping point to the saddle tie strapped on the CAC pipe shall be centered vertically on the CAC pipe and securely fastened with a tie strap. (Figure 2)
3. Air Compressor inlet hose routing shall be routed above and parallel to the fuel line, positioned in the highest clipping point in the stanchion bracket, and securely fastened with a tie strap. (Figure 3)
4. Tie straps located near the driver side motor mount shall have the sharp trimmed edges of tie straps rotated away from the Air Compressor Inlet Hose so sharp edges face the motor mount. (Figure 4 & 5)

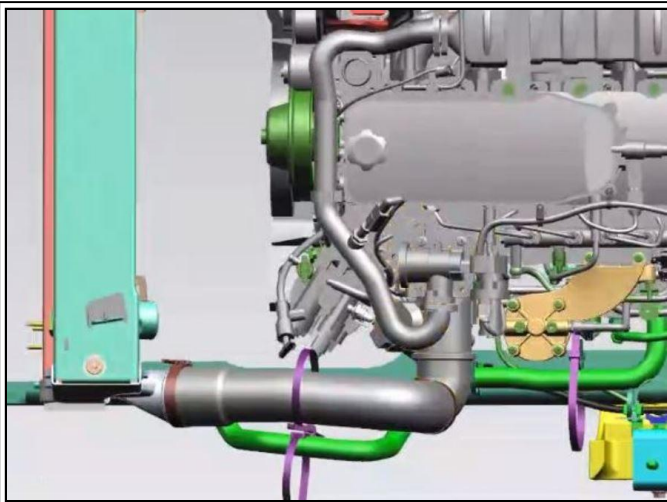

Figure 1: Top View - CAC pipe saddle & tie strap centered

The Air Compressor Intake Hose clipping point on the CAC pipe shall be centered horizontally and securely fastened with the saddle and tie strap.

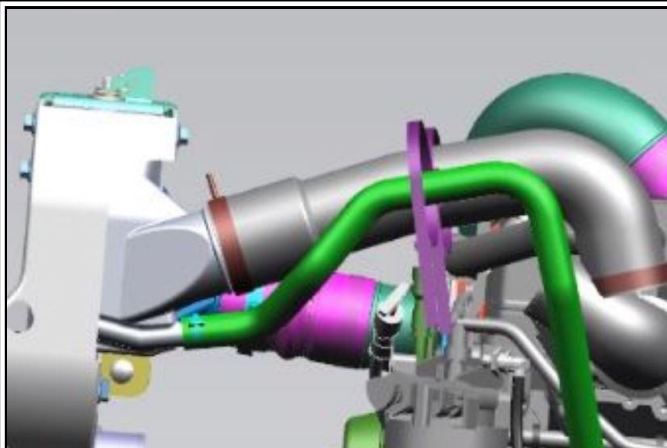

Figure 2: Side View - CAC pipe saddle & tie strap centered

Align the air compressor intake hose with the center of the saddle and tie strap. Pull the zip tie securing it against the

saddle while checking alignment.

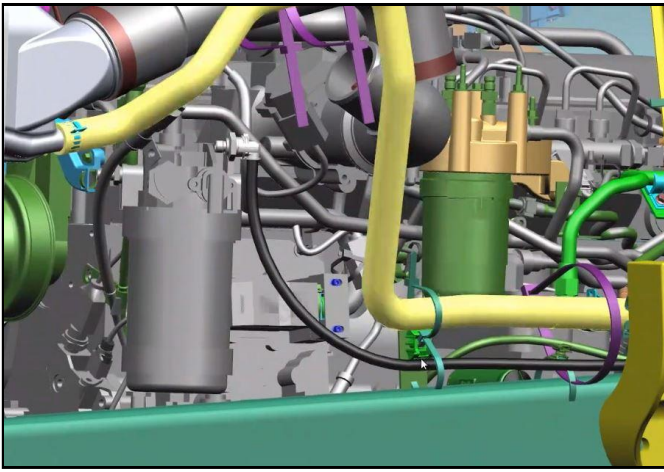

Figure 3: Air Compressor Inlet hose routed above fuel line

Air Compressor inlet hose routing shall be routed above and parallel to the fuel line, positioned in the highest clipping point in the stanchion bracket, and securely fastened with a tie strap.

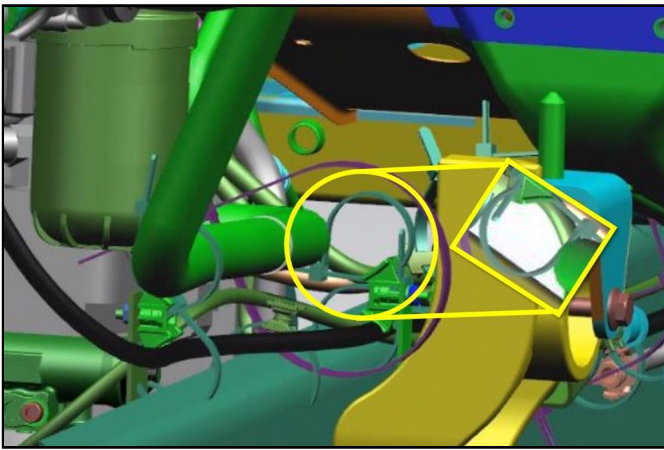

Figure 4: Rearward projection - Sharp Edge rotated to away

Align the air compressor intake hose with the center of the saddle and tie strap. Pull the zip tie securing it against the saddle while checking alignment. Trim sharp pieces of zip ties away from the hose to prevent damage and further rub point.

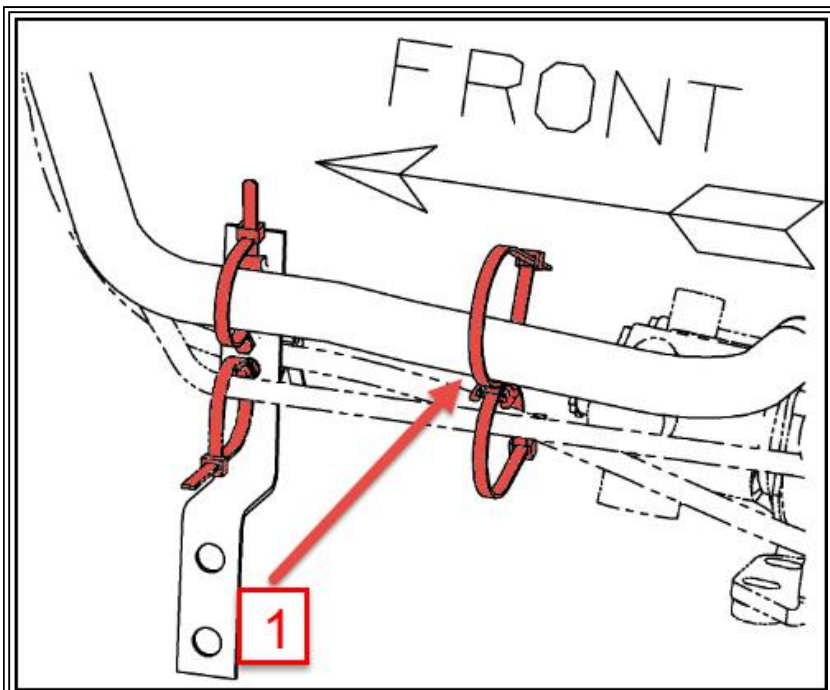

Figure 5: Air Compressor End Securement

Item 1: Ensure cable lock swivel PN 4077219C1 is installed between cable locks to allow for hose movement.

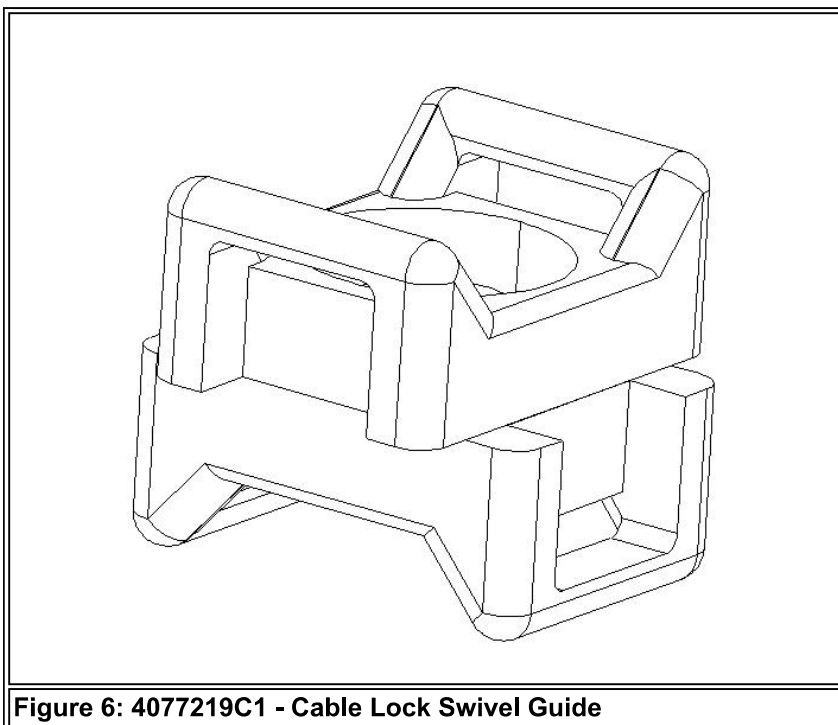

Figure 6: 4077219C1 - Cable Lock Swivel Guide

5. Start engine and check for leaks.
6. Close hood.
7. Remove wheel chocks.

WARRANTY INFORMATION

Warranty Claim Coding:

Refer to the [Warranty Coding Manual](#) for Group and Noun Codes.

Standard Repair Time(s):

Refer to the [SRT Manual](#) for Repair Times

Group:	04091- Air Brake System
Noun:	352

OTHER RESOURCES

[Master Service Information Site](#)

 Hide Details

Feedback Information

Viewed: 2530
Helpful: 6
Not Helpful: 0

No Feedback Found