



Allison Reduced Engine Load At A Stop (RELS) Diagnostic Trouble Code P071a Or P07ce - GR/TE Models Built, With The Split Shaft Package, June 2022 to October 2022



Internal Content

Requested by Body Builder Group

Suspect trucks that need wires moved were built between

June 2022 to Oct 2022 with a Gen 6 TECU where Fuel Sense was standard.

Description	Labor Code
Wiring Harness, Repair. Repair Only Qty. 1 (0.5 Hrs)	3700-16-02-01
Diagnostic Time QTY. 16 (1.6 Hrs.)	1700-16-03-01
Causal Part	P/N
Service Brake Switch	23155834

It is possible for GR/TE models built June 2022 to October 2022 to have Diagnostic Trouble Code P071a or P07ce along with complaints of the transmission not going in to neutral when coming to a stop and/or the transmission will go in to 4th gear lock up when applying the service brake.

This solution has been created for Concrete Pump and Vacuum Truck Applications with Split Box PTO



Before moving forward verify the transmission installed is equipped with a Split Shaft Package.

GR Model/PC28

Identify if the truck is equipped with a Round Gray or Rectangular Brown Allison Connector.

STEP 1

Connector location: Driver side behind lower panel

Round Gray Connector:

Look near this connector for a single wire connector marked Z11 RELS (Reduce Engine Load Stop) (See image below) If body builder has wire connected to that connector remove and install that wire in cavity U wire ID N143 on the body builder side of the connector.



Rectangular Brown Connector: Look near this connector for a single wire connector marked Z11 RELS (Reduce Engine Load Stop) (See image below) If body builder has wire connected to that connector remove and install that wire in cavity 18 Body Builder side of the Brown Connector. If a new terminal is needed please use p/n 978295.

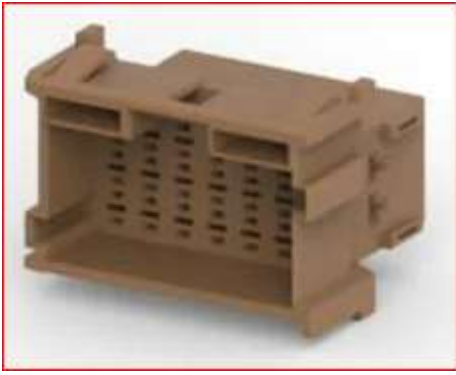

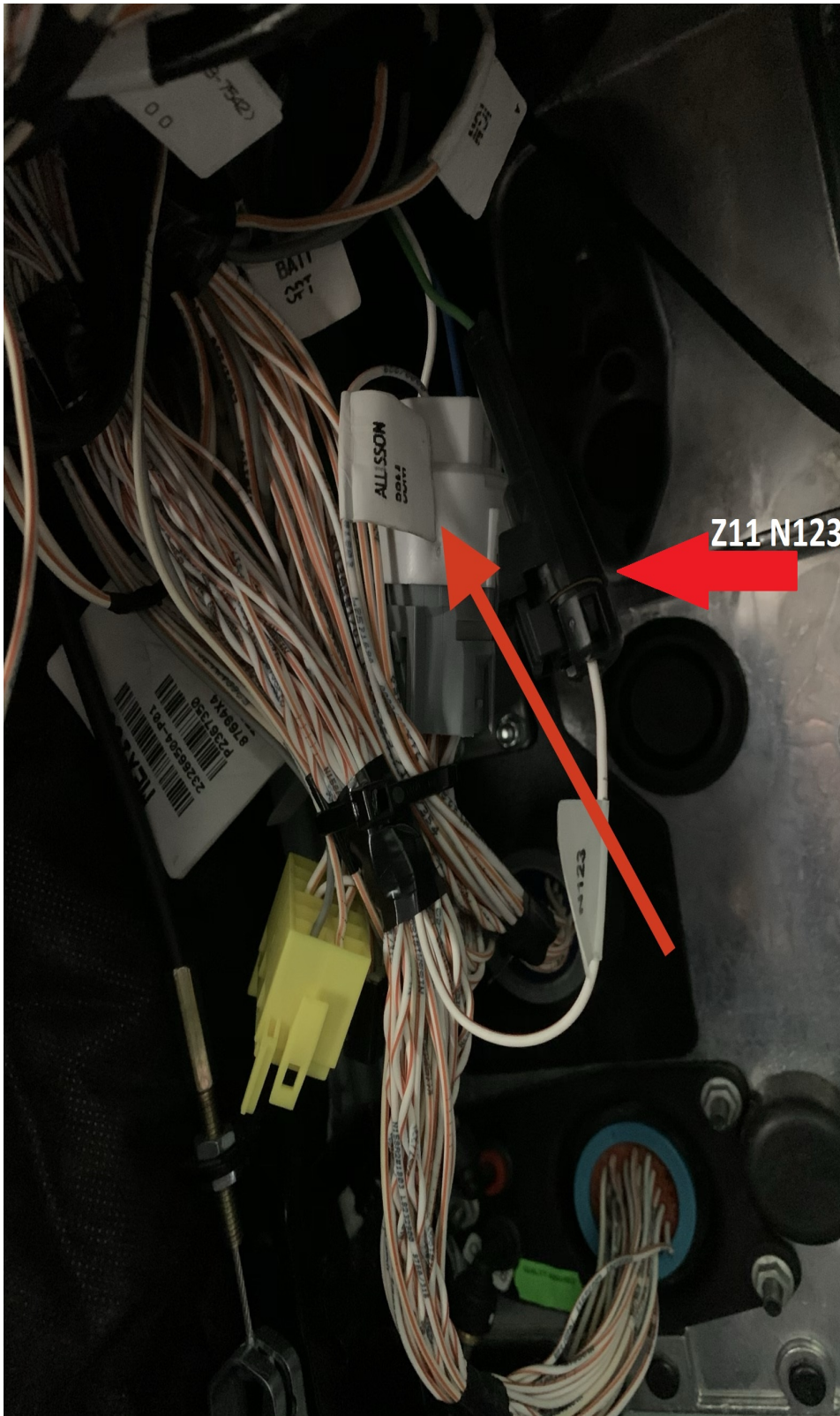

**If either Connector Gray or Brown is fully Populated on the Body Builder Side look for the Round RP170A 31 Pin Connector located at the back of cab and remove the Body Builder Wire from Cavity 18
Move it to Cavity 19.

 Live UI

****This Body Builder Wire is a signal wire from the Stiebel box Engagement Switch that will energize when in Pump Mode and signal PTO 2 Input for the Allison to go into 4th Lock up.**

Step 2

Move the 2 wires on the transmission ECU connector located behind the D panel (Allison 80 pin connector) (See Below)

- Move wire N143 move to Cavity 23
- Move wire N123 to Cavity 43

NOTE: You will not have to replace the terminal if you don't damage them when removing

- See the instructions on wire removal below

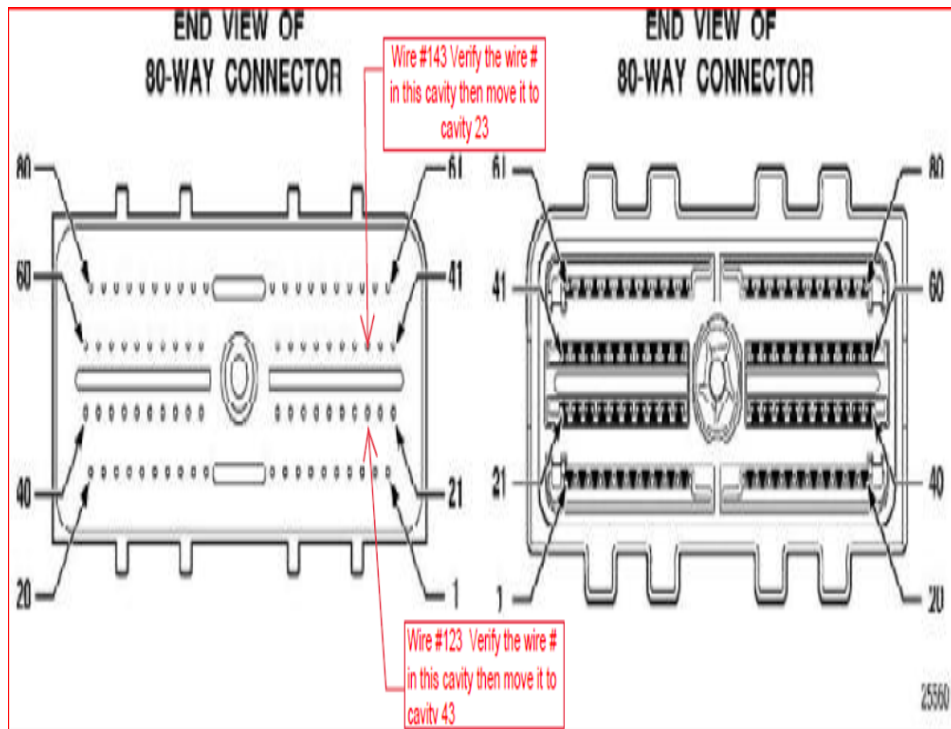

AFL 80F Bolt-Assist Transmission Control Module (TCM Connector)

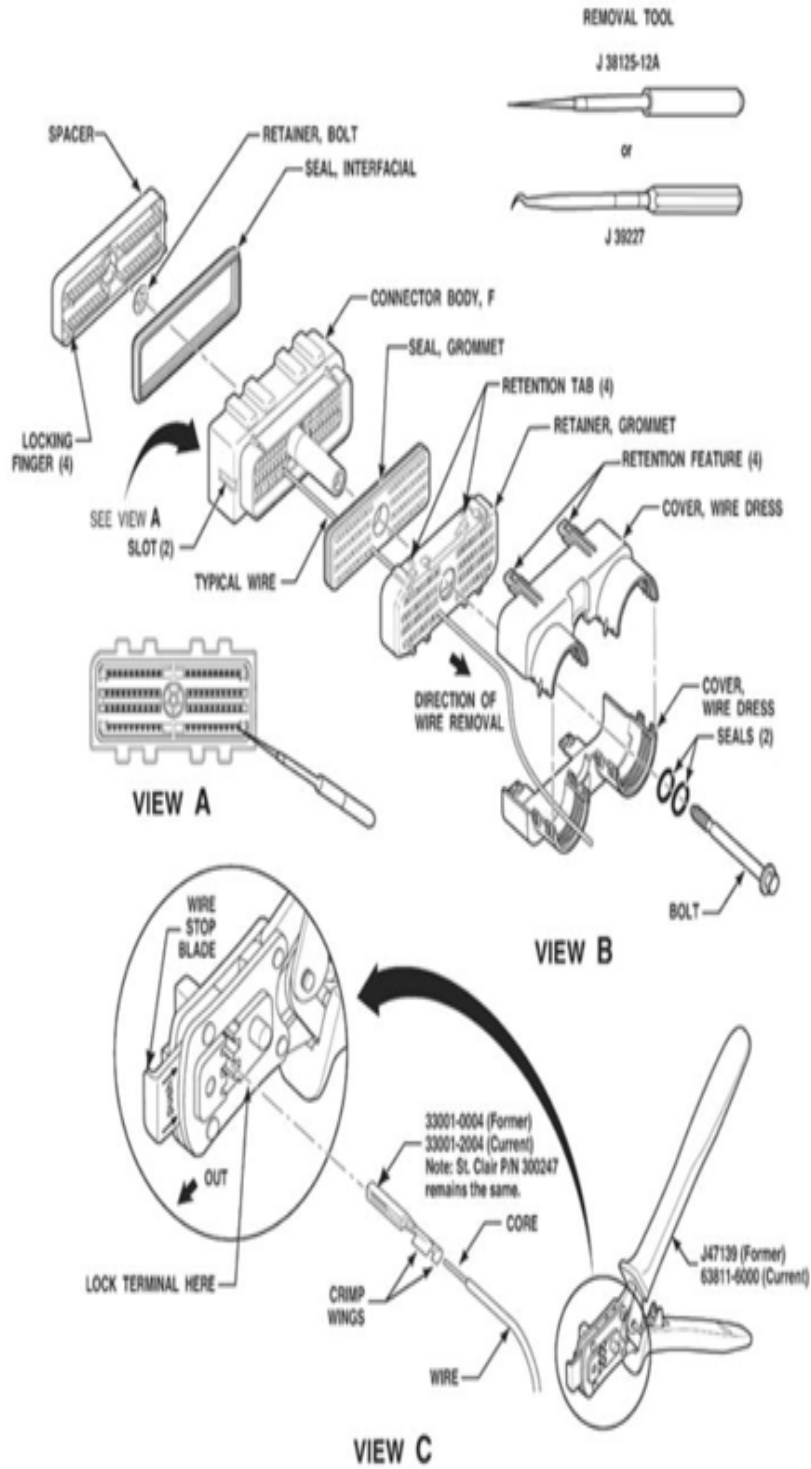

Example of 80-way Allison TECU Connector part #25371164

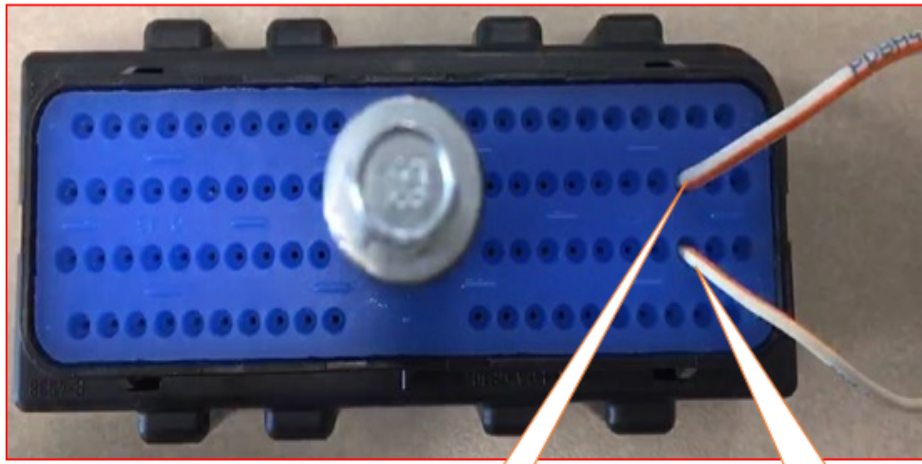

Cavity 43

Cavity 23

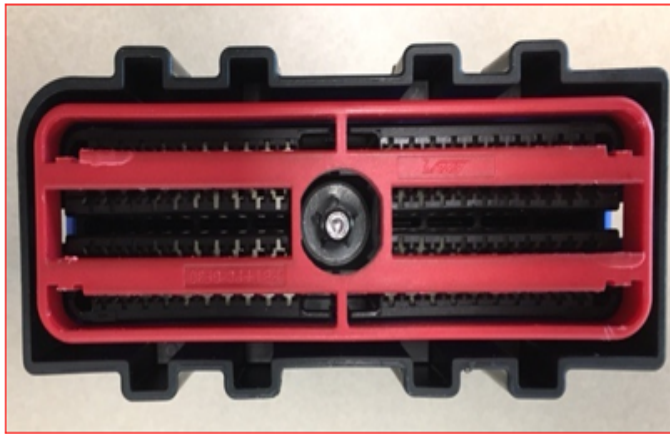

- After removing the 80-way connector, you will need to remove the red terminal lock terminal part #25193072 if needed

Locking fingers are located in each corner of the connector on the opposite side of the connector



Use these tools or similar, to unlock the red terminal lock



After lock has been removed you can use the terminal unlocking tool to unlock the wire terminal and slide the wire and terminal out the back side of the connector.



After you have swapped the wires in cavity 23 and 43, assemble the connector and plug it back in to the TECU and tighten the bolt. (DO NOT OVER TORQUE)

[80-Way: How to Identify and Repair Allison 80 Way Connector \(4th & 5th](#)

 [Live UI](#) [YouTube](#)

Step 3

Service Brake Switch Inspection

Visually inspect the service brake switch and verify that it is installed and the harness is connected.

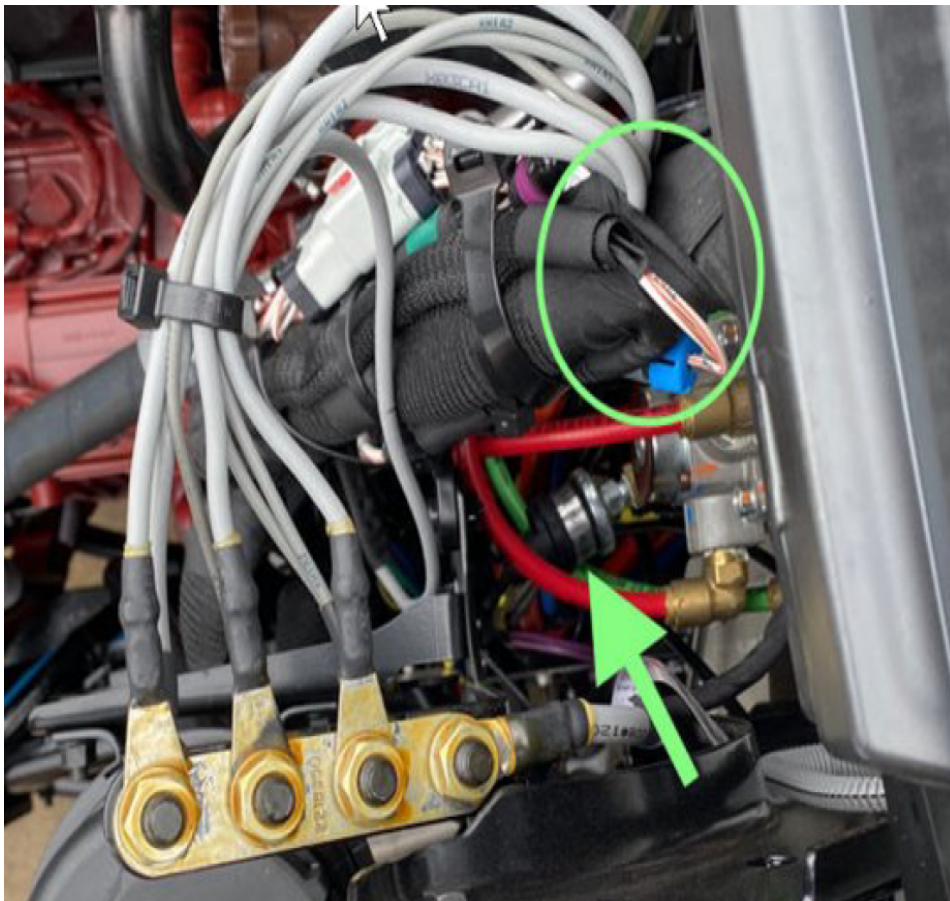

If the service brake switch has not been installed refer to the p/n below.

Description	P/N
Allison Brake Switch	29511309
NOTE: The Mack brake switch listed below should only be used if the Allison switch is unavailable	
Mack Brake Switch	25165995

 Live UI

After this repair has been completed please install a Campaign Completion Label (**P/N 85152363**). Fill out the label and use **CBR-2240** for the recall number. See illustrations below.

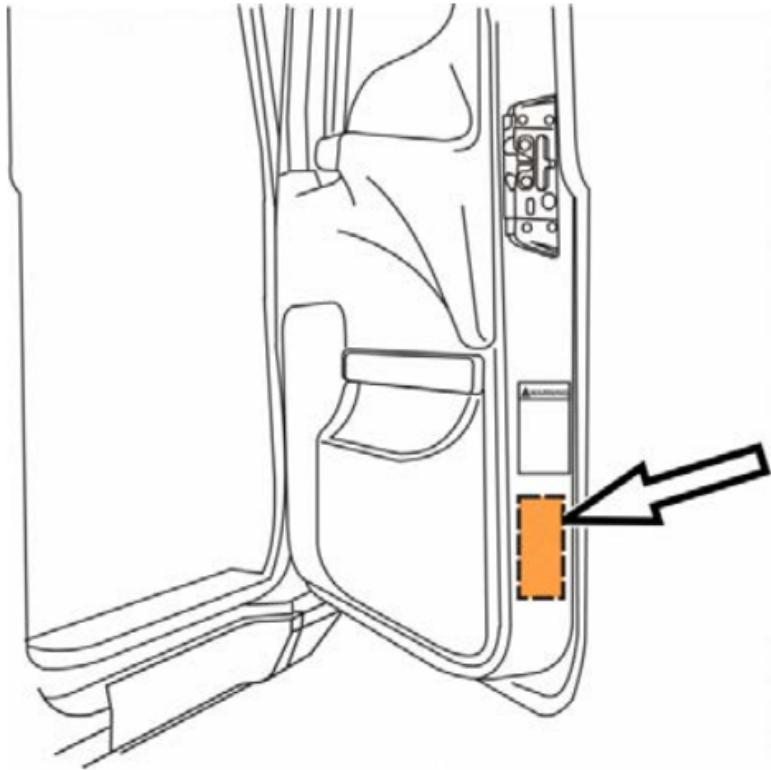

Warranty

When filing warranty please use the **service brake switch** as the causal part.

Causal Part	P/N
Service Brake Switch	23155834

TE/PC-29 Instructions

Step 1

 Live UI

Identify if you have a Round Gray or Rectangular Brown Allison Connector Z06D located next to driver seat. (See below)

Round Gray Connector: Install the wire from the Stiebel box engagement in cavity U wire ID N143.



Rectangular Brown Connector: Install the wire from the Stiebel box engagement wire in cavity 18 ID N143 Body Builder side of the Brown Connector. If a new terminal is needed please use p/n 978295.



**This Body Builder Wire is a signal wire from the Stiebel box Engagement Switch that will energize when in Pump Mode and signal PTO 2 Input for the Allison to go into 4th Lock up.

Step 2



move the 2 wires on the TECU (Allison 80 pin connector)

- Move wire N143 move to Cavity 23
- Move wire N123 to Cavity 43

TECU is located on right side of cab (A)

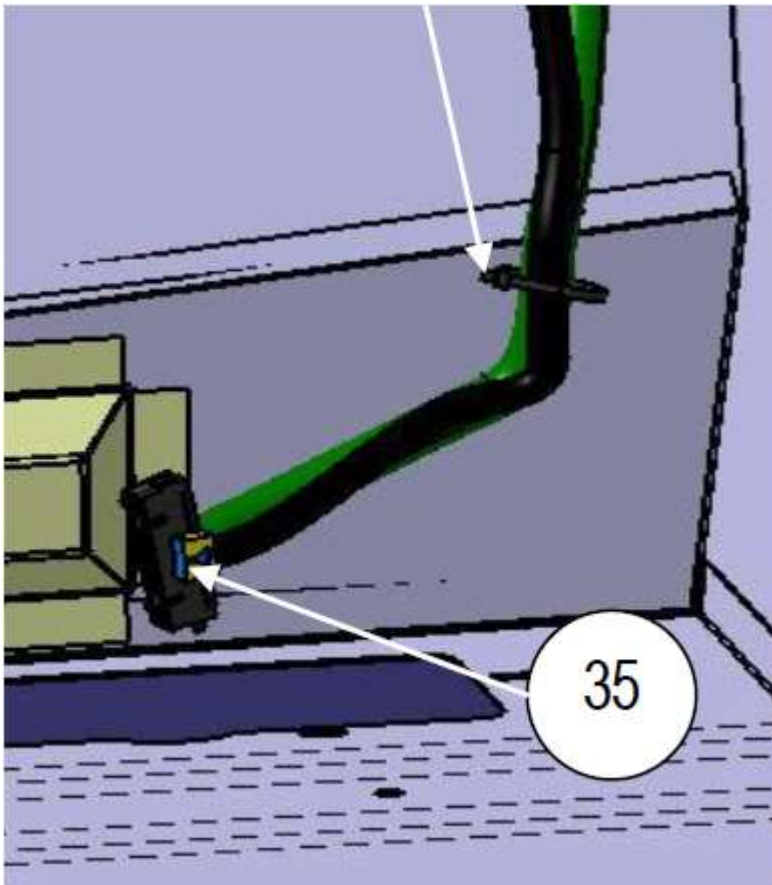
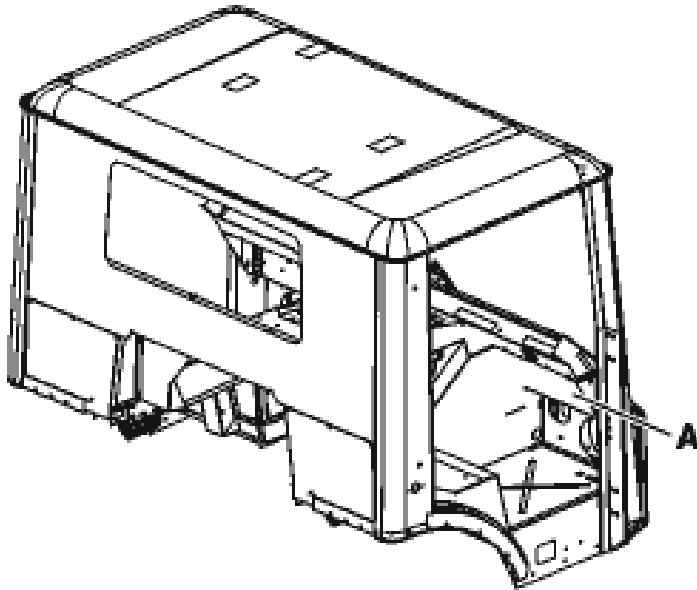

Live UI

NOTE: You will not have to replace the terminals if you don't damage them when removing

- See the instructions on wire removal below

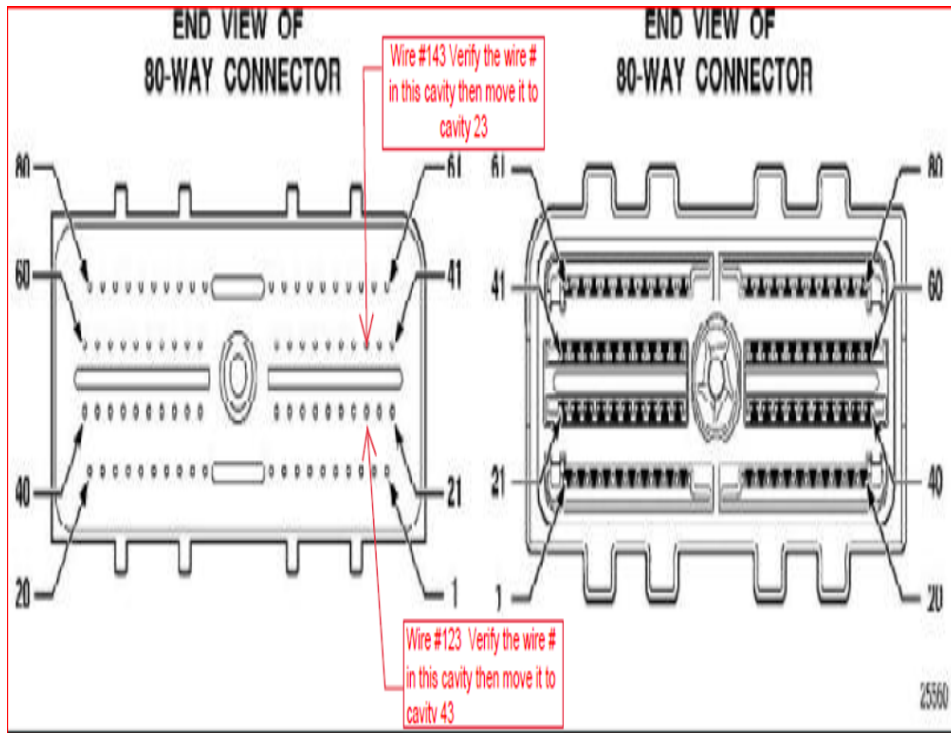

AFL 80F Bolt-Assist Transmission Control Module (TCM Connector)

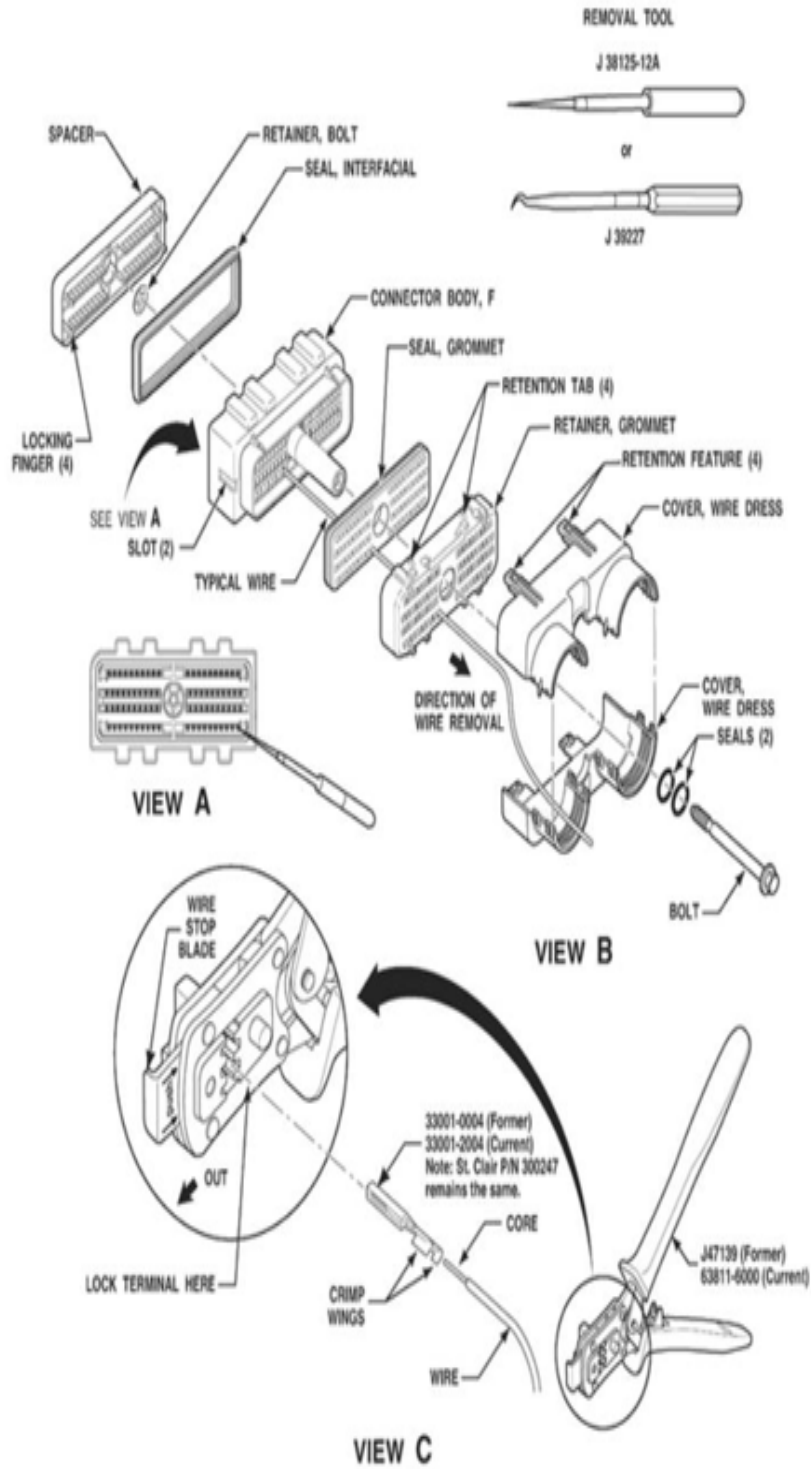

Example of 80-way Allison TECU Connector part #25371164

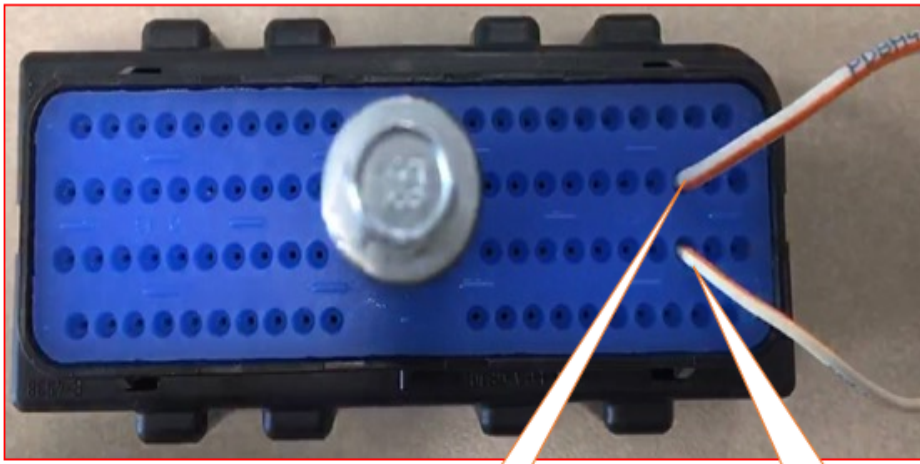

Cavity 43

Cavity 23

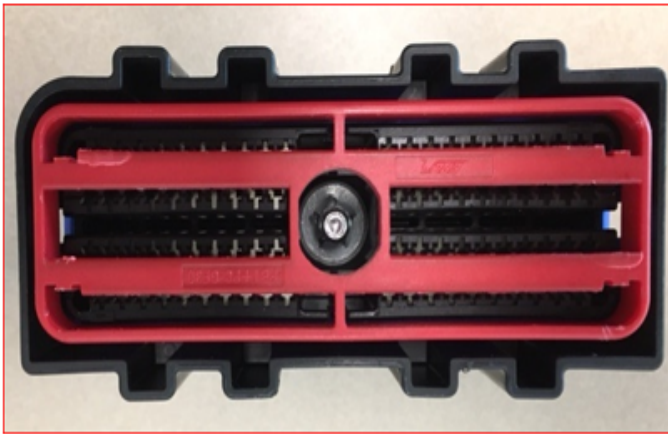

- After removing the 80-way connector, you will need to remove the red terminal lock terminal part #25193072 if needed

Locking fingers are located in each corner of the connector on the opposite side of the connector



Use these tools or similar, to unlock the red terminal lock



After lock has been removed you can use the terminal unlocking tool to unlock the wire terminal and slide the wire and terminal out the back side of the connector.



After you have swapped the wires in cavity 23 and 43, assemble the connector and plug it back in to the TECU and tighten the bolt. (DO NOT OVER TORQUE)

[80-Way: How to Identify and Repair Allison 80 Way Connector \(4th & 5th Gen\) - YouTube](#)

Step 3

Service Brake Switch Inspection

Visually inspect the service brake switch to verify that it is installed and the harness is connected. See image below.



 Live UI

If the service brake switch has not been installed refer to the p/n below.

Description	P/N
Allison Brake Switch	29511309
NOTE: The Mack brake switch listed below should only be used if the Allison switch is unavailable	
Mack Brake Switch	25165995

After this repair has been completed please install a Campaign Completion Label (**P/N 85152363**). Fill out the label and use **CBR-2240** for the recall number. See illustrations below.

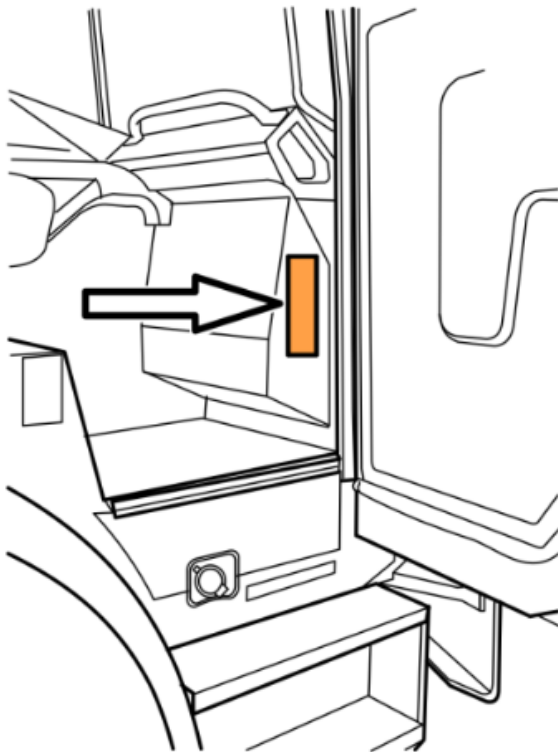

Warranty

When filing warranty please use the **service brake switch** as the causal part.

Causal Part	P/N
Service Brake Switch	23155834

 Live UI

 Tags

[p071a](#)

[p07ce](#)

[will not go in to neutral](#)

[allison](#)

[mack](#)

Categories 

[Make and Model > Mack > MRU/TE - TerraPro](#)

[Vehicle System > Transmission](#)

[Make and Model > Mack > GU/GR - Granite](#)

Related links and attachments

No links or attachments available



Feedback

[Give feedback](#)

to help improve the content of this article