



Countries: CANADA, UNITED STATES Document ID: IK0700119  
Availability: ISIS, NotSIR Revision: 0  
Major System: EXHAUST Created: 2/7/2023  
Current Language: English Last Modified: 2/13/2023  
Other Languages: NONE Author: Mujtaba Aidroos  
Viewed: 41

[Less Info](#)

Hide Details

Coding Information

<b>Copy Link</b> 	<b>Copy Relative Link</b> 	<b>Bookmark</b>  <a href="#">View My Bookmarks</a>	<b>Add to Favorites</b> 	<b>Print</b> 	<b>Provide Feedback</b> 	<b>Helpful</b>  2	<b>Not Helpful</b>  0
----------------------	-------------------------------	--	-----------------------------	------------------	-----------------------------	-------------------------	-----------------------------

**Title: HX - Vertical Exhaust S-Pipe Alignment**

**Applies To: HX with vertical exhaust**

## **DESCRIPTION**

This document will guide the user through aligning the S-Pipe on HX models with a vertical exhaust.

## **SYMPTOMS**

DTC/Light	Description
N/A	N/A

## **SPECIAL TOOLS / SOFTWARE**

Tool Description	Tool Number	Comments	Instructions
N/A	N/A	N/A	N/A

## **SERVICE PARTS INFORMATION**

Kit Description	Part Number	Qty. Required	Notes
N/A	N/A	N/A	N/A

## **DIAGNOSTIC STEPS**

N/A

## **REPAIR STEPS**

**WARNING!** To prevent property damage, personal injury, and / or death, park vehicle on a hard, flat surface, turn the engine off, set the parking brake, and install wheel chocks to prevent the vehicle from moving in either direction.

**WARNING!** To prevent property damage, personal injury, and / or death, if the vehicle must be raised, do not work under the vehicle supported only by jacks. Jacks can slip or fall over.

**WARNING!** To prevent personal injury and / or death, always wear safe eye protection when performing vehicle maintenance.

**WARNING!** To prevent property damage, personal injury, and / or death, keep flames or sparks away from vehicle and do not smoke while servicing the vehicle's batteries. Batteries expel explosive gases.

**WARNING!** To prevent property damage, personal injury, and / or death, remove the ground cable from the negative terminal of the battery box before disconnecting any electrical components. Always connect the ground cable last.

1. Bring vehicle into shop and park on a flat surface
2. Shift transmission into park or neutral, set parking brake and install wheel chocks
3. Remove S-pipe and mounting hardware leaving Aftertreatment and vertical exhaust in place

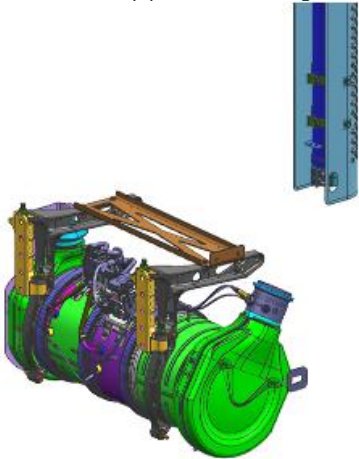

4. Install S-pipe to vertical exhaust pipe and align with aftertreatment outlet checking that vertical stack remains vertical

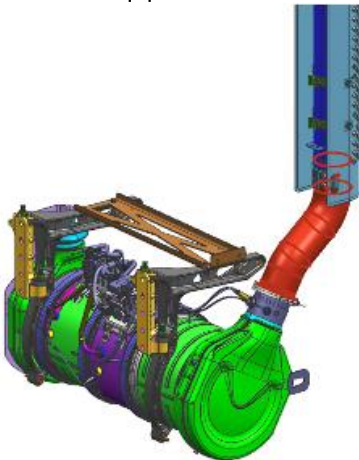

5. Install clamp on outlet of aftertreatment and tighten exhaust stack to S-pipe

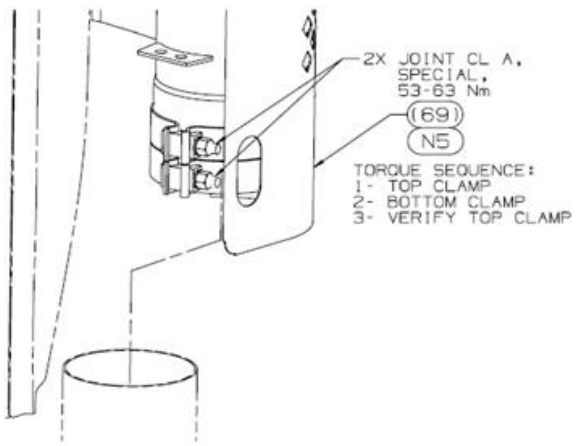

6. Tighten bolts on vertical stack

7. Install U-Bolt around S-Pipe and attach support to aftertreatment X-Plate (34Nm +/- 4Nm)

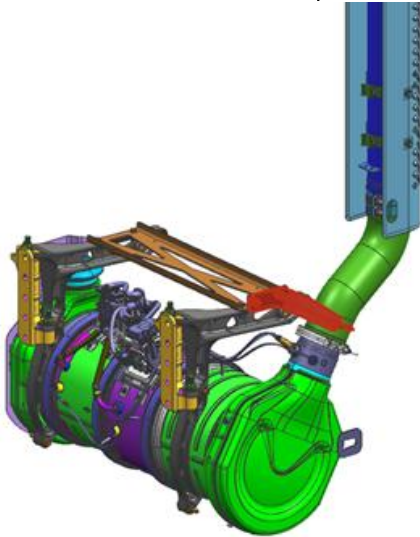

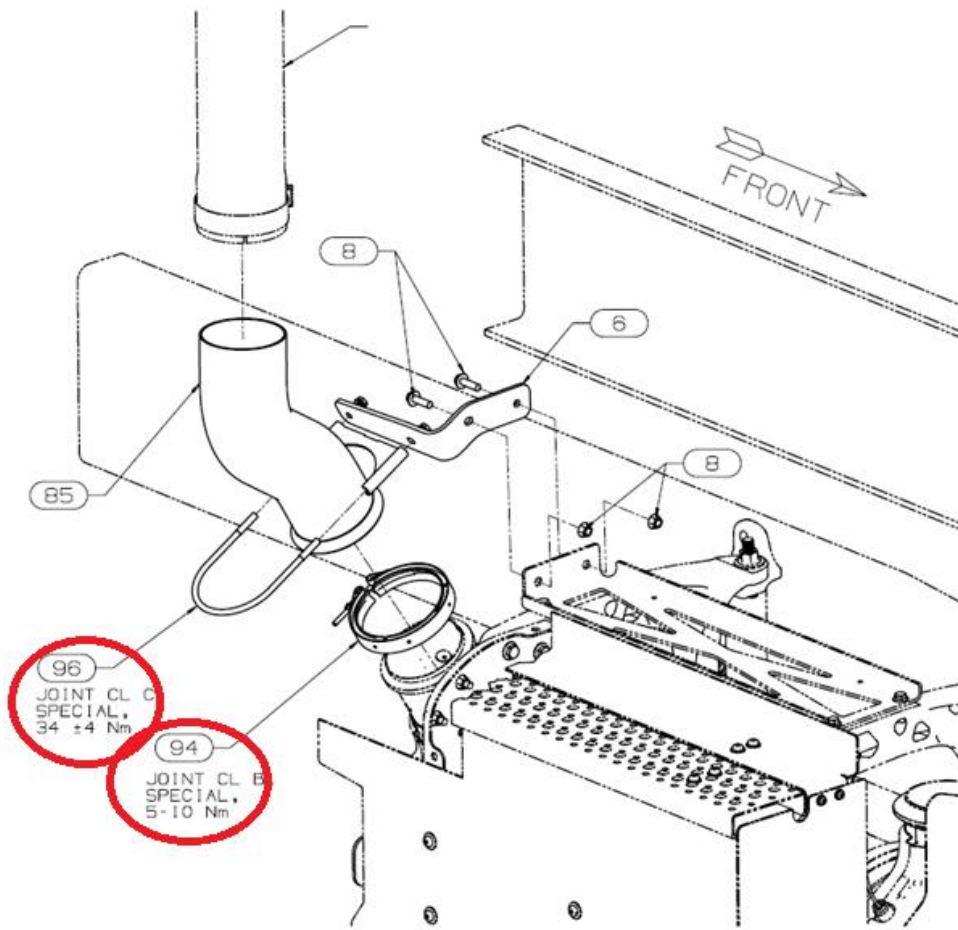

- 8. Remove wheel chocks
- 9. Return vehicle back to service

## **OTHER RESOURCES**

[Master Service Information Site](#)

Hide Details

Feedback Information

Viewed: 40  
Helpful: 2  
Not Helpful: 0

No Feedback Found