

Subject: ELECTRICAL DEVICES CANNOT BE CHARGED AT REAR CONSOLE OR TRUNK SIDE TRIM USB POWER OUTLET	Bulletin No.: 09-013/23
	Last Issued : 02/16/2023

BULLETIN NOTES

APPLICABLE MODEL(S)/VINS

2016-2023 CX-9 vehicles with VINs lower than JM3 TC**** ** 630018 (Produced before Aug. 1, 2022)

DESCRIPTION

Some customers may experience electrical devices that cannot be charged through the rear console or the trunk side trim USB power outlet. This may be caused by an excessive external force applied to the USB power outlet. To eliminate this concern, the soldering strength of the USB port has been enhanced.

Customers experiencing this concern should have their vehicle repaired using the following repair procedure.

REPAIR PROCEDURE

1. Verify the customer concern.
2. Replace the USB power outlet (1) on the rear console or trunk side trim with a modified part according to the instructions on MGSS online: (USB POWER OUTLET REMOVAL/INSTALLATION)

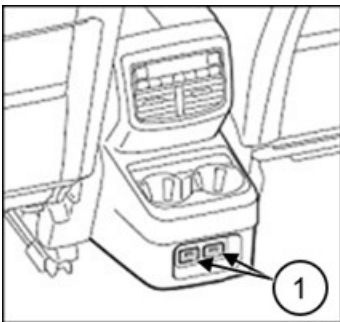

Rear Console

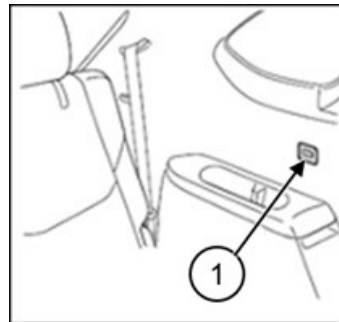

Trunk Side Trim

NOTE: Inform the customer of the following:

This concern may have been caused by an excessive external force applied to the USB power outlet. Although the outlet has been replaced with a more robust part, it can still be damaged if excessive force is applied to it, so please be careful not to trip over the charge cord.

3. Verify the repair.

CONSUMER NOTICE: The information and instructions in this bulletin are intended for use by skilled technicians. Mazda technicians utilize the proper tools/ equipment and take training to correctly and safely maintain Mazda vehicles. These instructions should not be performed by "do-it-yourselfers." Customers should not assume this bulletin applies to their vehicle or that their vehicle will develop the described concern. To determine if the information applies, customers should contact their nearest authorized Mazda dealership. Mazda North American Operations reserves the right to alter the specifications and contents of this bulletin without obligation or advance notice. All rights reserved. No part of this bulletin may be reproduced in any form or by any means, electronic or mechanical--including photocopying and recording and the use of any kind of information storage and retrieval system ---without permission in writing.

PARTS INFORMATION

Parts Number	Description	Qty.	Notes
TA0A-66-290A	Outlet	1	---

WARRANTY INFORMATION**NOTE:**

- This warranty information applies only to verified customer complaints on vehicles eligible for warranty repair.
- This repair will be covered under Mazda's New Vehicle Limited Warranty term.
- Additional diagnostic time cannot be claimed for this repair.

Warranty Type	A
Symptom Code	61
Damage Code	9W
Part Number Main Cause	TA0A-66-290A
Quantity	1
Operation Number / Labor Hours:	Trunk Side Trim (one side) - XXW9YERX / 0.5 Hrs. Rear Console - XXW9YDRX / 0.2 Hrs.

CONSUMER NOTICE: The information and instructions in this bulletin are intended for use by skilled technicians. Mazda technicians utilize the proper tools/ equipment and take training to correctly and safely maintain Mazda vehicles. These instructions should not be performed by "do-it-yourselfers." Customers should not assume this bulletin applies to their vehicle or that their vehicle will develop the described concern. To determine if the information applies, customers should contact their nearest authorized Mazda dealership. Mazda North American Operations reserves the right to alter the specifications and contents of this bulletin without obligation or advance notice. All rights reserved. No part of this bulletin may be reproduced in any form or by any means, electronic or mechanical--including photocopying and recording and the use of any kind of information storage and retrieval system ---without permission in writing.