

GLOBAL SAFETY FIELD INVESTIGATIONS  
DCS6471  
URGENT - DISTRIBUTE IMMEDIATELY

Date: March 2, 2023

Subject: N222391310 - Service Update  
Torque Converter Housing Access Hole Cover Not Installed

Models: 2023 Chevrolet Silverado 2500HD/3500HD  
2023 GMC Sierra 2500HD/3500HD  
Equipped with TRANSMISSION-AUTO 10 SPD, 10L1000, GRX, GEN  
1, VAR 1 (RPO MGM)

To: All General Motors Dealers

General Motors is releasing Service Update N222391310 today. The total number of U.S. vehicles involved is approximately 6. Please see the attached bulletin for details.

**Global Warranty Management (GWM)**

The Required Field Action section on the Investigate Vehicle History (IVH) screen will be updated March 2, 2023. A list of vehicles in dealer inventory is attached to this message.

END OF MESSAGE

GLOBAL SAFETY FIELD INVESTIGATIONS

# Service Update

## N222391310 Torque Converter Housing Access Hole Cover Not Installed



**Release Date:** March 2023

**Revision:** 00

**Attention:** This service update includes vehicles in dealer inventory and customer vehicles that return to the dealership for any reason. This bulletin will expire at the end of the involved vehicle's New Vehicle Limited Warranty period.

Make	Model	Model Year		RPO	Description
		From	To		
Chevrolet	Silverado 2500HD/3500HD	2023	2023	MGM	TRANSMISSION-AUTO 10 SPD, 10L1000, GRX, GEN 1, VAR 1
GMC	Sierra 2500HD/3500HD				

Involved vehicles are marked "Open" on the Investigate Vehicle History screen in GM Global Warranty Management system. This site should always be checked to confirm vehicle involvement prior to beginning any required inspections and/or repairs.

<b>Condition</b>	Certain 2023 model year Chevrolet Silverado 2500HD/3500HD and GMC Sierra 2500HD/3500HD vehicles, may have a condition in which the torque converter housing access hole cover was not installed.
<b>Correction</b>	Dealers are to install the torque converter housing access hole cover.

### Parts

Quantity	Part Name	Part No.
1	Torque Converter Housing Inspection Port Dust Cover	24205900

It is estimated that only 8 involved vehicles will require parts replaced. Due to the small number of vehicles anticipated that will need this fix and the limited initial parts availability, dealers are encouraged not to order these parts for use as shelf stock.

**Reminder:** Parts will be removed from SPRINT and may be removed from Retail Inventory Management (RIM). Dealers should review the affected parts to confirm RIM managed status. Parts may have quantity limiters in effect.

### Warranty Information

Labor Operation	Description	Labor Time	Trans. Type	Net Item
9106733	Torque Converter Housing Access Hole Cover Installation	0.2	ZFAT	N/A

### Service Procedure

1. Lift the vehicle. Refer to *Lifting and Jacking the Vehicle* in SI.

## Service Update

# N222391310 Torque Converter Housing Access Hole Cover Not Installed

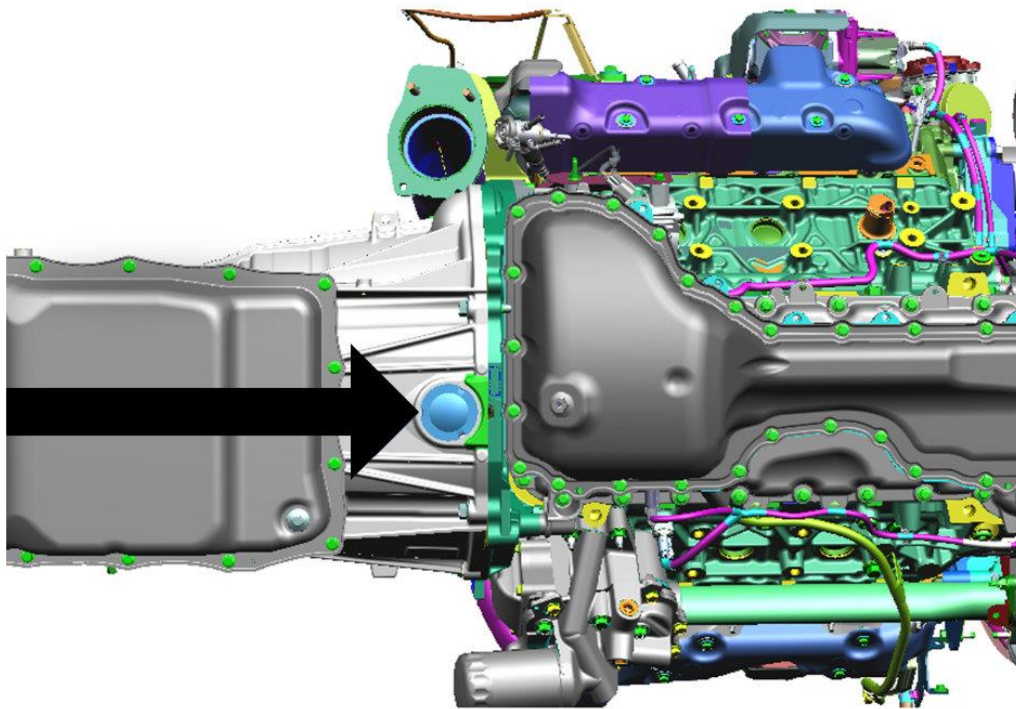

6281257

2. Snap the torque converter housing access hole cover into the inspection port located on the underside of the bellhousing, indicated by the arrow above.
3. Lower the vehicle. Refer to *Lifting and Jacking the Vehicle* in SI.

### Dealer Responsibility

Whenever a vehicle subject to this service update enters your vehicle inventory or is in your facility for service in the future, and the vehicle is still covered under the New Vehicle Limited Warranty, you must take the steps necessary to be sure the service update correction has been made before selling or releasing the vehicle.

All new, used, GM Certified Used, courtesy transportation vehicles, dealer shuttle vehicles, etc. in dealers' possession and subject to this bulletin must be held and inspected/repared per the service procedure of this bulletin before customers take possession of these vehicles. Involved vehicles must be held and not delivered to customers, dealer-traded, released to auction, used for demonstration, or any other purpose.

All GM Certified Used vehicles currently in the dealers' inventory within the Certified Pre-Owned Inventory System (CPOIS) will be de-certified and must be held and remedied per the service procedure in this bulletin. Upon submitting an accepted/paid warranty transaction in the Global Warranty Management (GWM) system, the vehicle can be re-certified for sale within the CPOIS system, or once again be used in the CTP program.

### Dealer Reports – For USA & Export

The Inventory tab of the Open Vehicle Report will contain Service Update Bulletin VINs that apply to this field action. This information is intended to assist dealers with the **PROMPT COMPLETION** of these vehicles. The Customer In-Service tab will not contain Service Update Bulletin VIN data because the intent of a Service Update Bulletin is to not inconvenience a customer with a special trip for service. Service Update Bulletins are to be completed when the customer is in for a regularly scheduled visit.

GM bulletins are intended for use by professional technicians, NOT a "do-it-yourselfer". They are written to inform these technicians of conditions that may occur on some vehicles, or to provide information that could assist in the proper service of a vehicle. Properly trained technicians have the tools, equipment, safety instructions, and know-how to do a job properly and safely. If a condition is described, **DO NOT** assume that the bulletin applies to your vehicle, or that your vehicle will have that condition. See your dealer for information on whether your vehicle may benefit from the information.



We Support  
Voluntary Technician  
Certification