



HYUNDAI Technical Service Bulletin

GROUP BODY	NUMBER 23-BD-003H
DATE FEBRUARY, 2023	MODEL(S) PALISADE (LX2)

SUBJECT: SUNROOF WIND DEFLECTOR AND MECHANISM REPLACEMENT

Description: On certain Palisade (LX2) vehicles, the sunroof wind deflector may fail and cause damage to the sunroof mechanism. The sunroof may become inoperable and stuck in the open, partially open, or closed position. This bulletin describes the procedure to replace the sunroof wind deflector and sunroof mechanisms with revised parts.

Applicable Vehicles: Certain 2020 – 2022MY Palisade (LX2) vehicles equipped with a sunroof and produced before 5/4/2022.

Parts Information:

PART NAME	PART NUMBER	FIGURE	CONTENTS
Wind Deflector Arm Sub-Assy Kit	81690-S8000FFF		Wind deflector arm (LH side)
			Wind Deflector arm (RH side)
Mechanism Sub-Assy Kit (LH side)	81610-S8000FFF		Carriage bar (LH side)
			Driving wedge (LH side)
			Curve guide A (LH side)
			Curve guide B (LH side)

SUBJECT: SUNROOF WIND DEFLECTOR AND MECHANISM REPLACEMENT

Mechanism Sub-Assy Kit (RH side)	81620-S8000FFF		Carriage bar (RH side)
			Driving wedge (RH side)
			Curve guide A (RH side)
			Curve guide B (RH side)

Warranty Information:

MODEL	OP. CODE	OPERATION	OP. TIME	CAUSAL PART	NATURE CODE	CAUSE CODE
Palisade (LX2)	81690F01	SUNROOF WIND DEFLECTOR ARMS AND MECHANISM REPLACEMENT (ONE SIDE ONLY)	0.8 M/H	81690-S8000FFF	I11	ZZ3
	81690F02	SUNROOF WIND DEFLECTOR ARMS AND MECHANISM REPLACEMENT (BOTH SIDES)	1.0 M/H			

NOTE: Normal Warranty Applies.

Service Procedure:

A. Sunroof Wind Deflector Arm Replacement

1. Open the sunroof glass by pressing the sunroof switch.

If the sunroof cannot be opened with the sunroof switch, refer to the shop manual for the emergency operating procedure.



Body (Interior and Exterior) > Sunroof > Repair Procedures > Emergency Operation

2. Remove the wind deflector screws and remove the wind deflector (A).

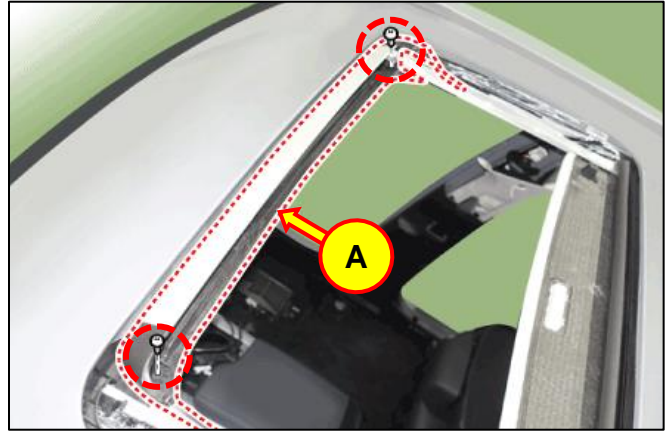

3. Press the locking tabs by inserting a flat-head screwdriver in the indicated holes (B) and remove the wind deflector arms (C) on both sides.

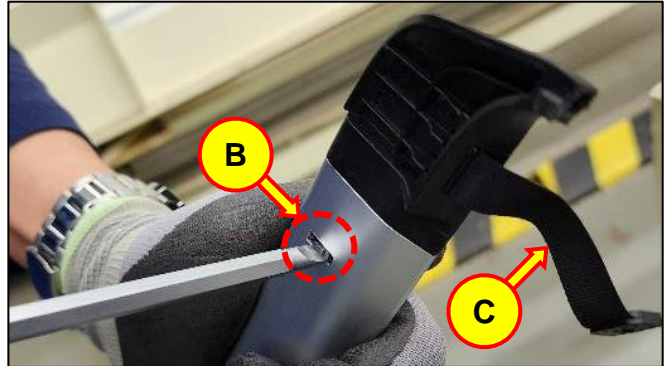
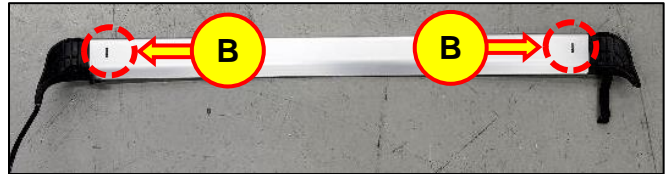

4. Install the new wind deflector arms (D) onto the wind deflector (A).

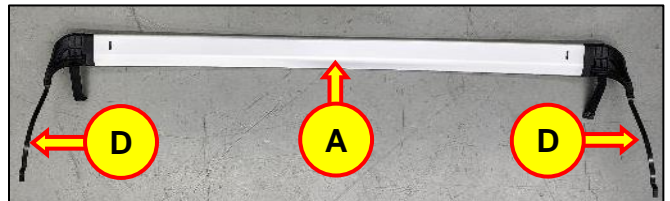

5. Reinstall the wind deflector (A).

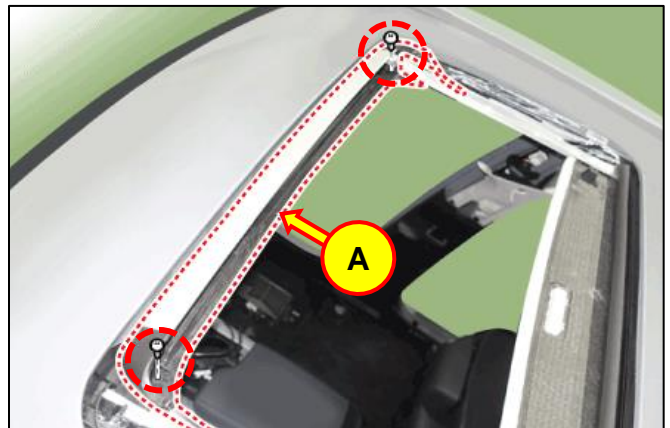

B. Sunroof Mechanism Parts Replacement

1. Move the sunroof glass into the tilt position by pressing the sunroof switch.

If the sunroof cannot be moved with the sunroof switch, refer to the shop manual for the emergency operating procedure.

Body (Interior and Exterior) > Sunroof > Repair Procedures > Emergency Operation

2. Remove the sunroof mechanism covers (E) on both sides.

***i* Information**

- Push the cover forward approximately 1/2 in. until it aligns with the groove (F), then pull it towards the center of the vehicle.

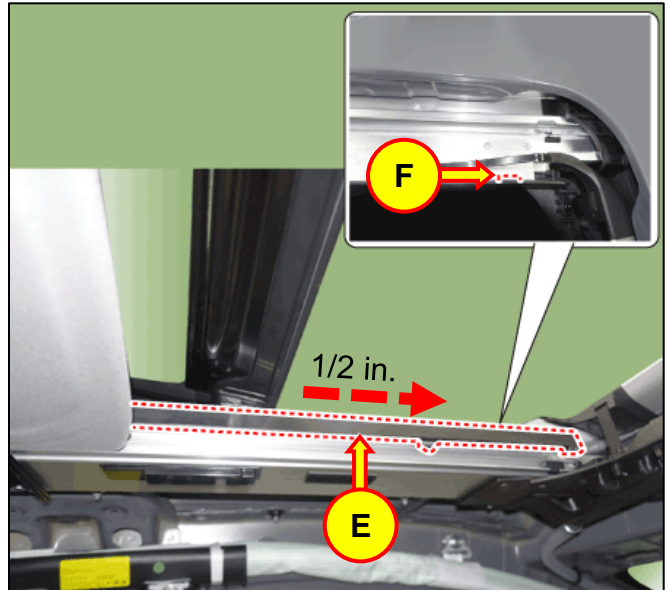

3. Remove the interior sunroof glass bolts (G) on both sides (6 total).

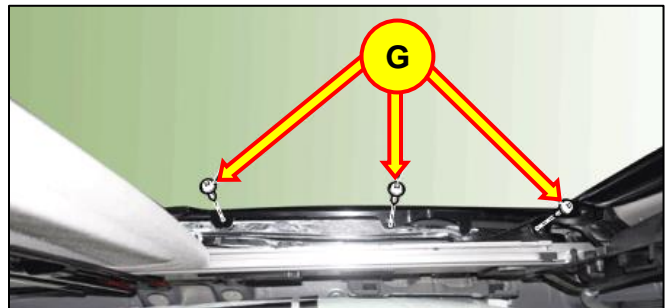

4. Carefully lift and remove the sunroof front glass (H).

NOTICE

- Assistance may be required to safely lift and remove the glass.
- Place the glass on a workbench with a soft surface to prevent damage.

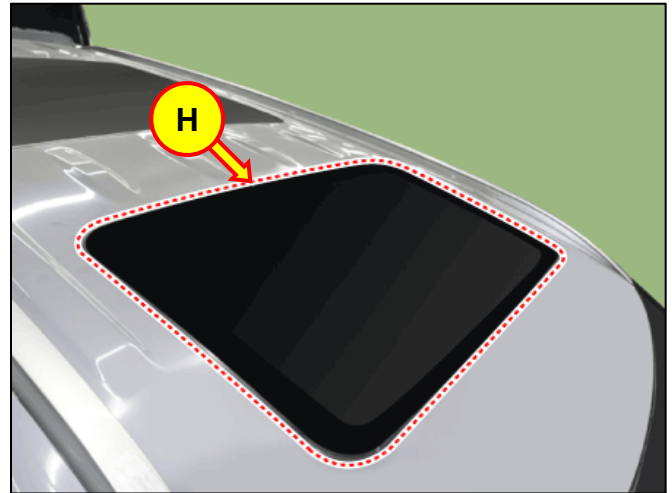

5. Inspect both sides of the sunroof mechanism (I) for any damage or debris.
- Only replace the side(s) that is damaged or broken.

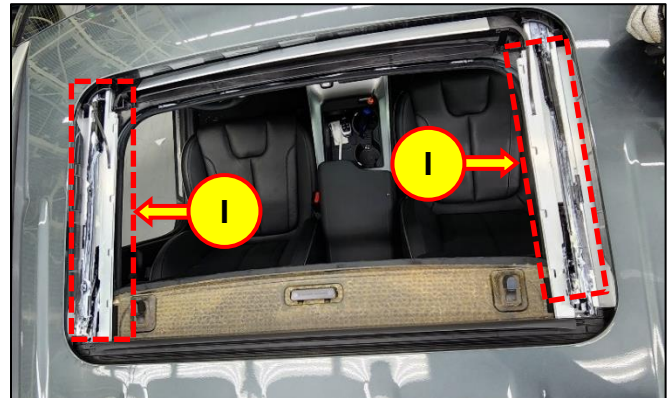

6. Disconnect curve guide B (K) from curve guide A (J).

Use a flat-head screwdriver to lightly tap (towards the front of the vehicle) on the indicated metal tab on curve guide B (K).

Refer to the photos on the following page for the exact location of the metal tab on curve guide B (K) and the direction to apply force.

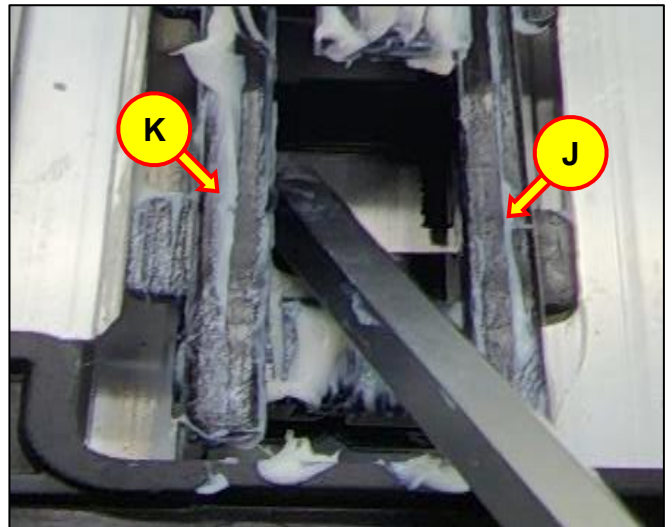

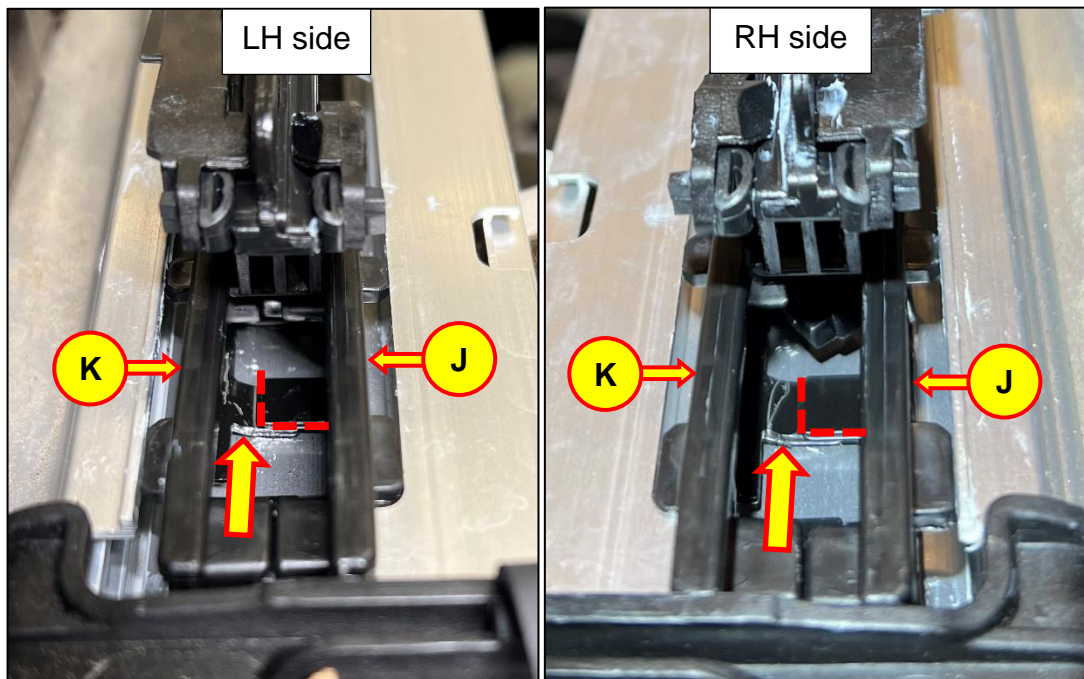

7. Use the sunroof switch to move the sunroof mechanism rearwards (approx. 2 in) past the cutout in the sunroof rail.

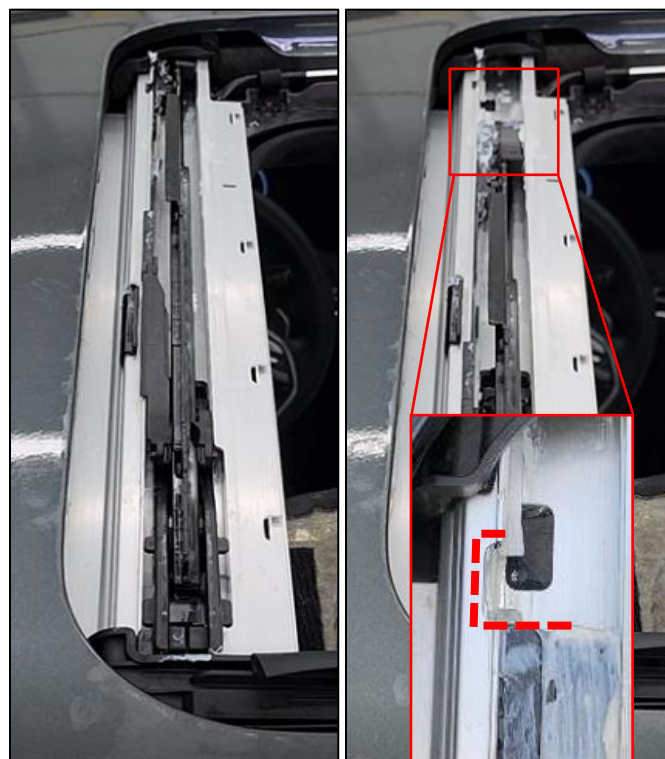

8. While lifting the rear of the carriage bar (L), separate the driving wedge (M) from the curve guides.

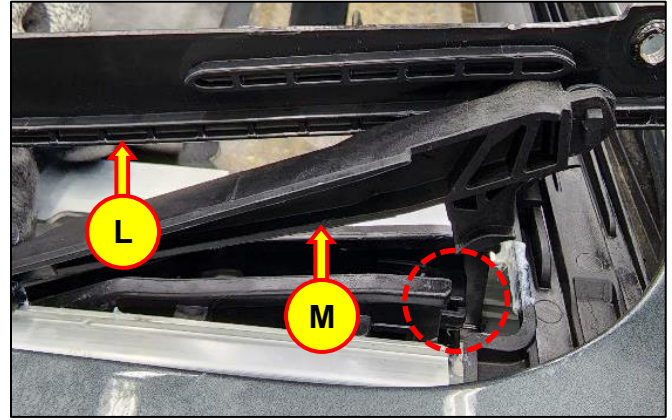

9. While lifting the rear of the carriage bar (L), disconnect the locking tab of the driving wedge (M).

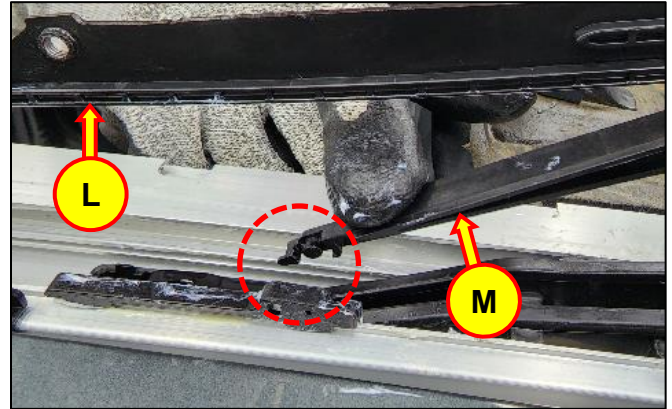

10. Slide the driving wedge (M) off the carriage bar (L).

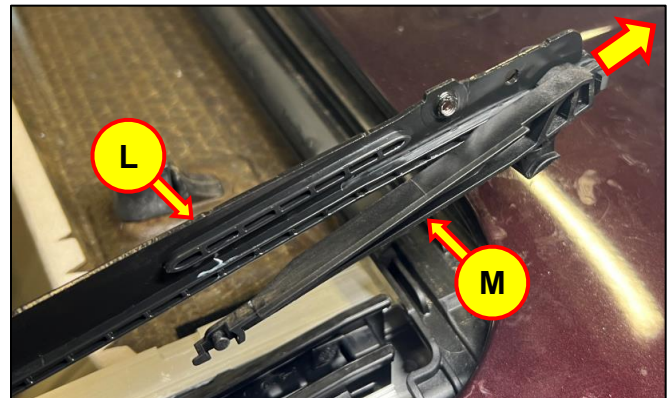

11. Push the carriage bar (L) forward past the cutout in the rail, then remove it.

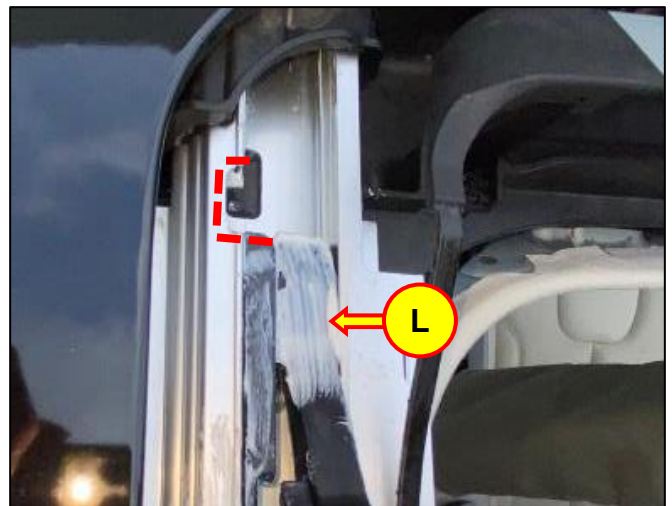

12. Remove the curve guide B (K) first, then remove the curve guide A (J).

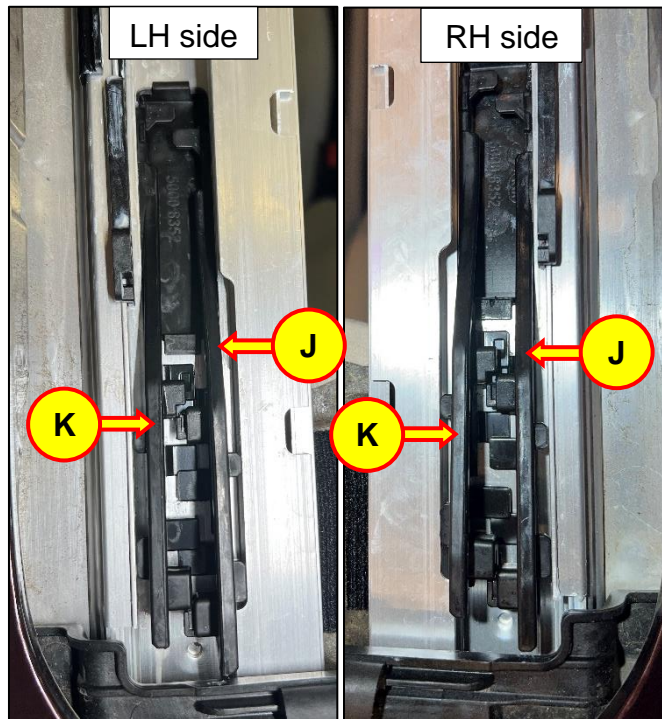

13. Inspect the sunroof mechanism rail(s) for any debris and remove any contaminants.



14. Install the new curve guide A (J) into the sunroof mechanism rail.

i Information

- Align the groove on the bottom of new curve guide A (J) with the slot in the rail.

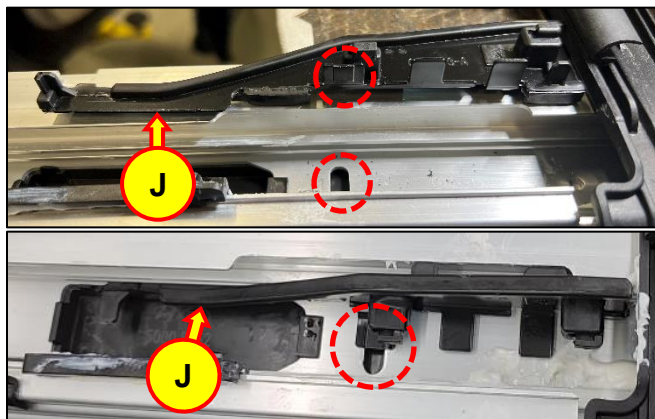

15. Install the new curve guide B (K) into the sunroof mechanism rail.

i Information

- Position curve guide B (K) ahead of curve guide A (J). Both curve guides should parallel with each other and the indicated locking tabs (N) should be aligned.
- Do not push both curve guides together until step 20.

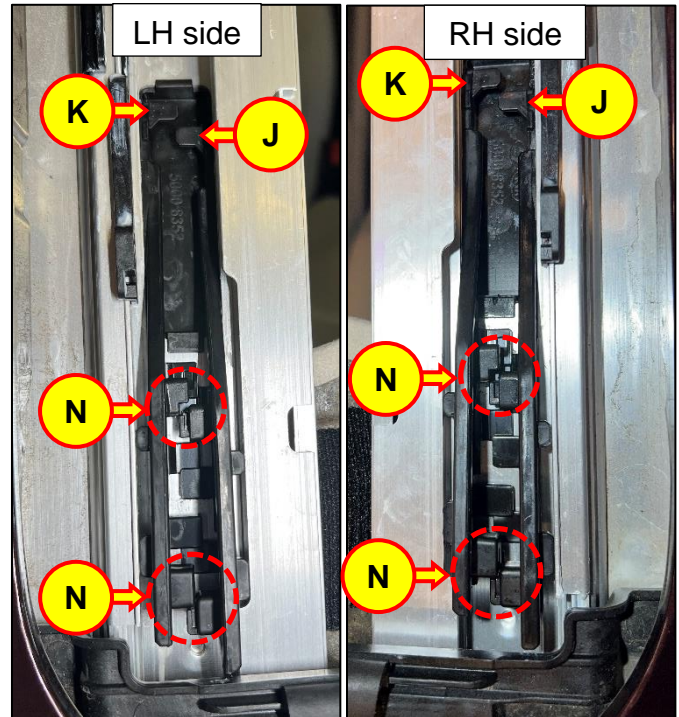

16. Install the new carriage bar (L) into the sunroof mechanism.

i Information

- The tabs on the new carriage bar (L) should align with the indicated slots in the sunroof mechanism.

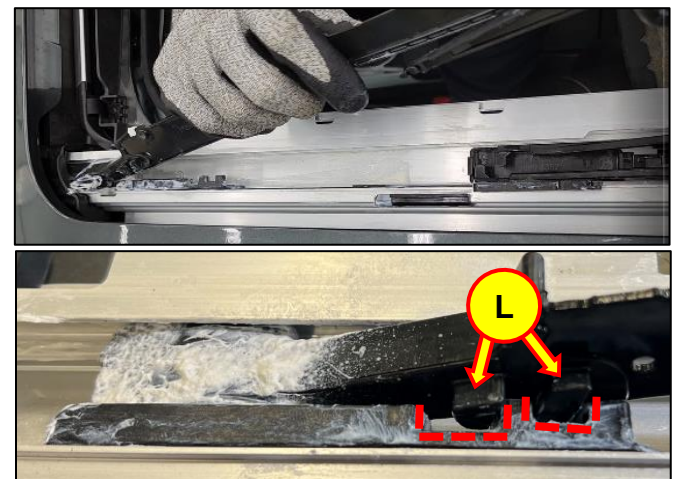

17. Install the new driving wedge (M) onto the new carriage bar (L).

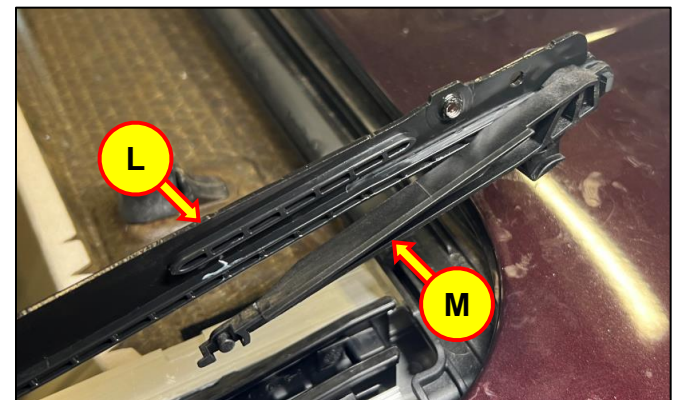

18. Install the locking tab of the new driving wedge (M) into the locking slide (O) of the sunroof mechanism.

i Information

- Move the new driving wedge (M) as needed to align the locking tab with the locking slide (O). It may also be necessary to lift the carriage bar at a 30° angle.

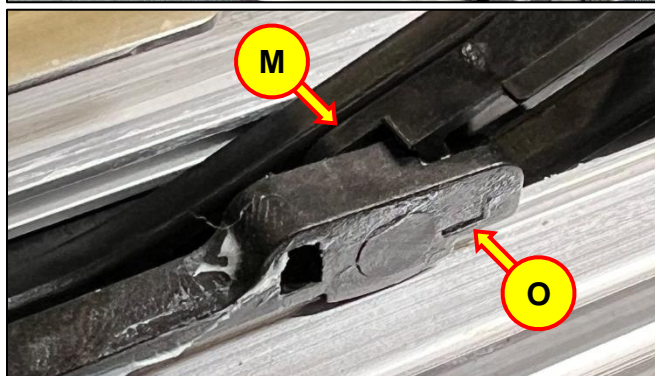
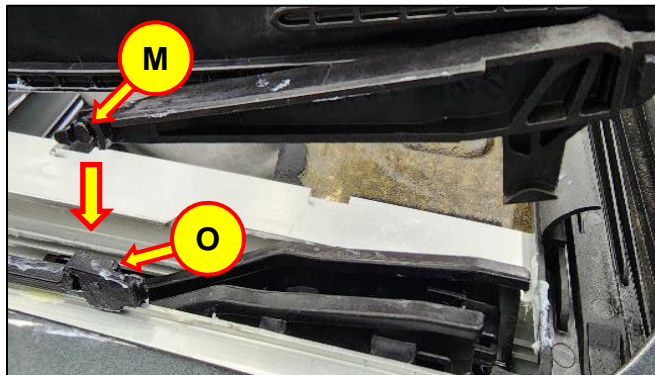

19. Lower the new driving wedge (M) and insert it in between both curve guides (K).

i Information

- Realign both curve guides (K) if they are moved out of position when installing the new driving wedge (M).

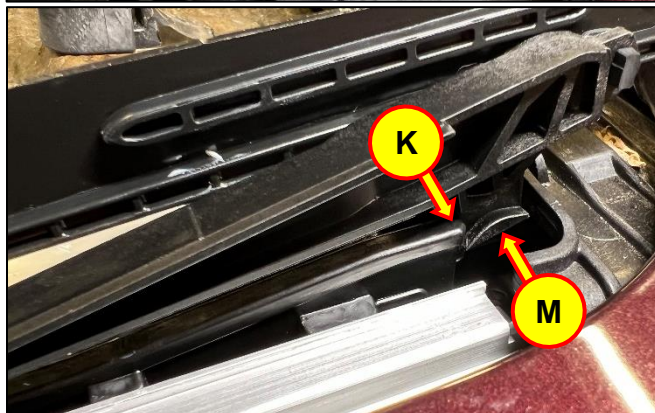
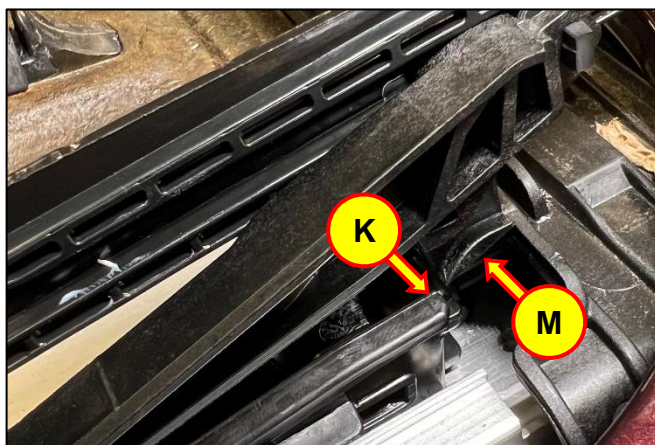

20. Lightly tap the indicated metal surface on curve guide B (K) with a flat head screwdriver to push it rearwards until it is fully seated with curve guide A (J).

NOTICE

- Ensure the locking tabs (N) of both curve guides are properly aligned beforehand.
- Do not tap on the locking tabs (N).
- Do not use excessive force when tapping on the metal surface of curve guide B (K).
- Damage to the curve guides may occur if the previous steps are not followed.

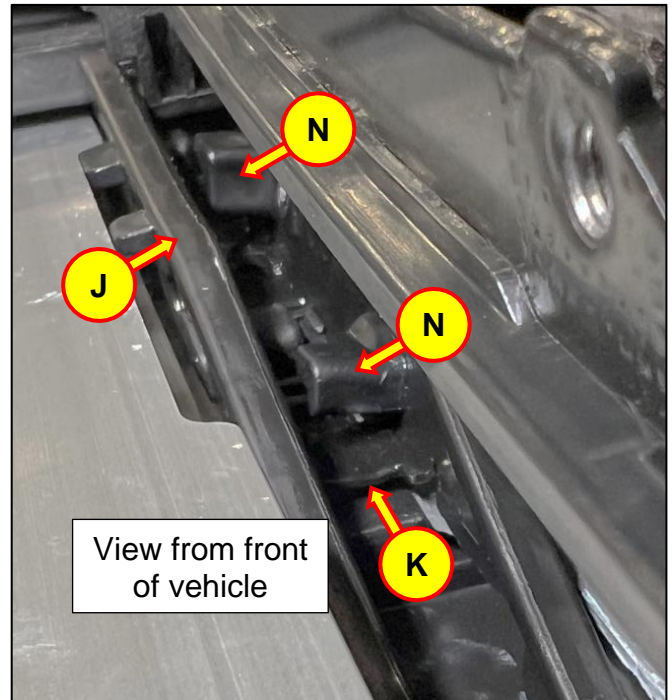

21. Apply white lithium grease to the new carriage bar (L).



22. Perform the sunroof reset procedure and test for normal open/close and tilt functions of the sunroof mechanism.

Refer to the owner's manual for the complete sunroof reset procedure.



- 23. Place the sunroof mechanism in the tilt position.
- 24. Reinstall the sunroof glass (H).

NOTICE

- Ensure that the sunroof mechanism has been reset and fully tested before reinstalling the sunroof glass.

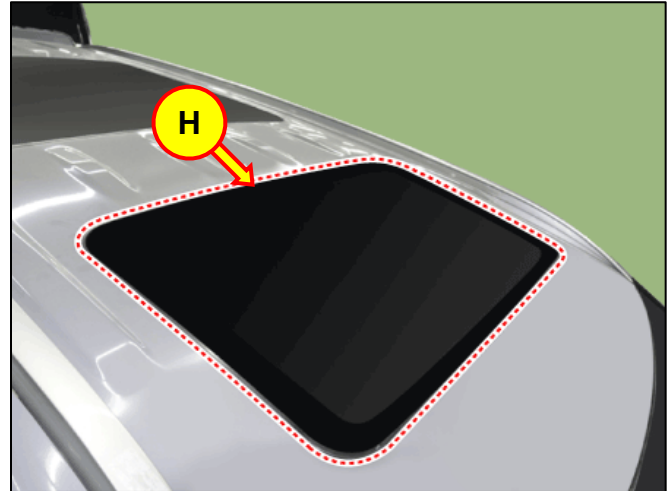

- 25. Reinstall the sunroof mechanism covers on both sides (E).

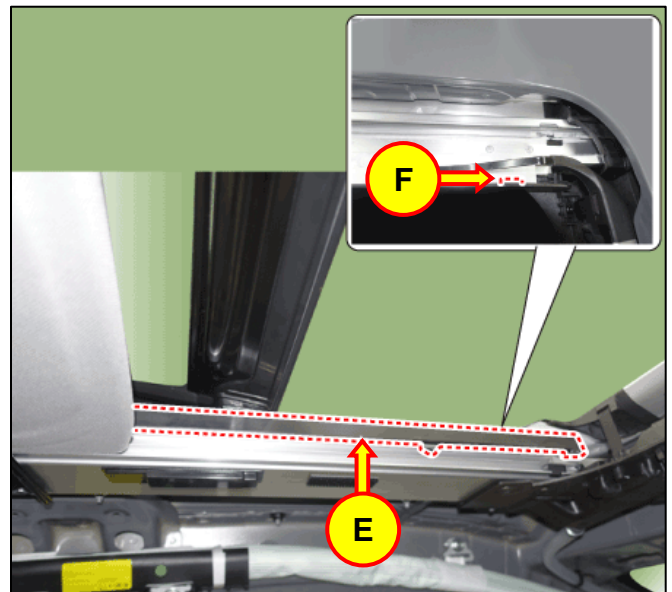

- 26. The service procedure is now complete.