

RCA-30-23-001-1: Update Battery Management System Firmware

Rivian is initiating a customer satisfaction campaign for some model year 2022 R1T vehicles that may have an outdated version of the battery management system (BMS) firmware. This firmware version may prevent over the air software updates, resulting in delayed access to new features. Rivian will manually update the BMS firmware. Rivian is launching this campaign for customer satisfaction and to ensure the quality of Rivian vehicles.

Document Type	Customer Satisfaction Campaign Bulletin
Date	February 16, 2023
Affected Region(s)	USA
Affected Model(s)	R1T
Model Year(s)	2022
Approximate Build Dates  Refer to the FSA Dashboard to determine if this document applies to a specific vehicle.	October 2021 - June 2022
Vehicle System	30 - HV Battery
Minimum Service Location	Mobile

Procedure

1. Remove: Duct, HVAC, Intake, Upper, Front (refer to service manual procedure 266441010).
2. Connect float chargers to the 12V batteries.
3. Remove: Panel, Underbody, Rear Subframe (refer to service manual procedure 606516010).
4. Note the serial number near the bottom of the highlighted label.

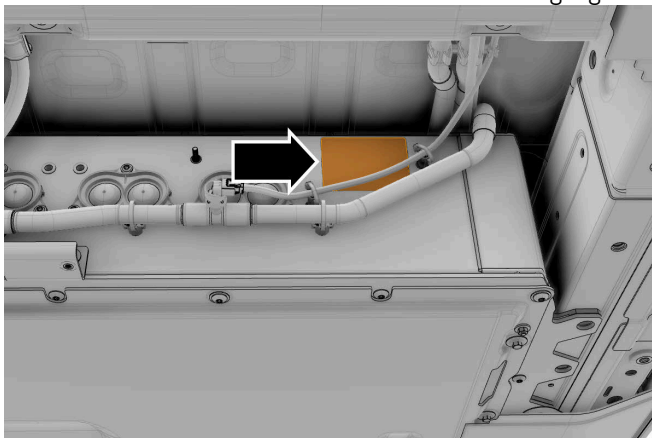

Note: Shown with components removed for clarity.

5. Escalate for diagnostic assistance.
6. Reinstall all components that were removed for access and replace all non-reusable components. Refer to the service manual procedures referenced in this document for additional component reusability information and torque specifications.

Labor Codes

Labor Code	Description
RCA302300100	RCA-30-23-001 not applicable
RCA302300101	Update battery management system firmware to re-enable software updates
<i>Contact ServiceDocumentFeedback@rivian.com regarding labor codes and document content.</i>	