

GLOBAL SAFETY FIELD INVESTIGATIONS
DCS6439
URGENT - DISTRIBUTE IMMEDIATELY

Date: February 9, 2023

Subject: REVISION: N222372590-02 – Service Update
Charge Air Cooler Icing
Revised Parts, Warranty, Service Procedure sections

Models: 2016 – 2022 Buick Encore
2016 – 2019 Chevrolet Cruze
2018 – 2022 Chevrolet Equinox
2016 – 2021 Chevrolet Malibu
2014 – 2022 Chevrolet Trax
2018 – 2022 GMC Terrain

To: All General Motors Dealers

This bulletin is being revised to update the parts section, warranty information section, and the service procedure. Please discard all previous copies of bulletin N222372590.

END OF MESSAGE
GLOBAL SAFETY FIELD INVESTIGATIONS

Service Update

N222372590 Charge Air Cooler Icing



Release Date: February 2023

Revision: 02

Revision Description: This bulletin is being revised to update the parts section, warranty information section, and the service procedure. Please discard all previous copies of bulletin N222372590.

Attention: This service update will expire June 30, 2024.

Make	Model	Model Year		RPO	Description
		From	To		
Buick	Encore	2016	2022		
Chevrolet	Cruze	2016	2019		
Chevrolet	Equinox	2018	2022		
Chevrolet	Malibu	2016	2021		
Chevrolet	Trax	2014	2022		
GMC	Terrain	2018	2022		

Involved vehicles are marked "Open" on the Investigate Vehicle History screen in GM Global Warranty Management system. This site should always be checked to confirm vehicle involvement prior to beginning any required inspections and/or repairs.

Condition	Certain vehicles listed above may have a condition in which ice or sludge can accumulate in the Charge Air Cooler (CAC) or Closed Crankcase Ventilation (CCV) system when driving in extremely cold weather conditions (-18°C (0°F) or less).
Correction	Dealers will install a TCV thermal wrap and, if applicable, reprogram the Engine Control Module.

Parts

Quantity	Part Name	Part No.
1	TCV Thermal Wrap	25205589
1 (If Req)	Turbocharger Wastegate Regulator Solenoid Valve	55573259*
1 (If Req)	Turbocharger Wastegate Regulator Solenoid Valve	55599331*
1 (If Req)	Turbocharger Wastegate Regulator Solenoid Valve	12649146*

Note: *Do NOT order for shelf stock. It is estimated that only 1% of the vehicles will require Turbocharger Wastegate Regulator Solenoid Valve replacement. Use the VIN and the GM Electronic Parts Catalog (EPC) to determine which Turbocharger Wastegate Regulator Solenoid Valve to order, if required.

Reminder: Parts may be removed from Retail Inventory Management (RIM). Dealers should review the affected parts to confirm RIM managed status. Parts may have quantity limiters in effect.

Warranty Information

Labor Operation	Description	Labor Time	Trans. Type	Net Item
9106505*	Remove Turbocharger Wastegate Regulator Solenoid Valve, test, apply thermal wrap, and recalibrate ECM (includes OAT relearn if necessary) 2018+ Encore 2018+ Cruze Equinox/Terrain 2018+ Malibu 2018+ Trax	1.3 0.7 1.0 0.8 1.3	ZFAT	N/A
9106506*	Remove Turbocharger Wastegate Regulator Solenoid Valve, test, apply thermal wrap, and verified ECM programming level 2018+ Encore 2018+ Cruze Equinox/Terrain 2018+ Malibu 2018+ Trax	0.9 0.5 0.8 0.4 0.9		
9106569	Remove Turbocharger Wastegate Regulator Solenoid Valve, test, apply thermal wrap, and clear Diagnostic Trouble Codes (DTCs) 2016-2017 Encore 2016-2017 Cruze 2016-2017 Malibu	0.9 0.5 0.4		

Service Update

N222372590 Charge Air Cooler Icing



2014-2017 Trax Equinox/Terrain (LTG Only)	0.9 0.8	
--	------------	--

Important: * To avoid warranty transaction rejections, carefully read and follow the instructions below:

Labour Time [\[Top\]](#)

Labour Operation Code:

Additional labour op code information:

SPS Warranty Claim Code:

6125814

- The Warranty Claim Code from the programming event must be accurately entered in the “Warranty Claim Code” field of the transaction.
- When more than one Warranty Claim Code is generated for a programming event, it is required to document all Warranty Claim Codes in the “Correction” field on the job card. Dealers must also enter one of the codes in the “Warranty Claim Code” field of the transaction, otherwise the transaction will reject. It is best practice to enter the FINAL code provided by SPS2.

Warranty Claim Code Information Retrieval

VIN	Module	Function	Warranty Claim Code	Job Card
[REDACTED]	K73 - Telematics Communication Interface Control Module	Programming & Service Activation	[REDACTED]	test
[REDACTED]	K9 - Body Control Module	Programming	[REDACTED]	test
[REDACTED]	K5 - Automatic Level Control Module Ignition	Off	[REDACTED]	test driver
[REDACTED]	K56 - Serial Data Gateway Module	Programming	[REDACTED]	test driver

6125774

If the Warranty Claim Code was not recorded on the Job Card, the code can be retrieved in the SPS2 system as follows:

1. Open TLC on the computer used to program the vehicle.
2. Select and start SPS2.
3. Select Settings (1).
4. Select the Warranty Claim Code tab (2).

The VIN, Warranty Claim Code and Date/Time will be listed on a roster of recent programming events. If the code is retrievable, dealers should resubmit the transaction making sure to include the code in the SPS Warranty Claim Code field.

Service Update

N222372590 Charge Air Cooler Icing



Service Procedure

Note: All vehicles model year 2018 and newer require **BOTH** the thermal wrap and ECM reprogramming.

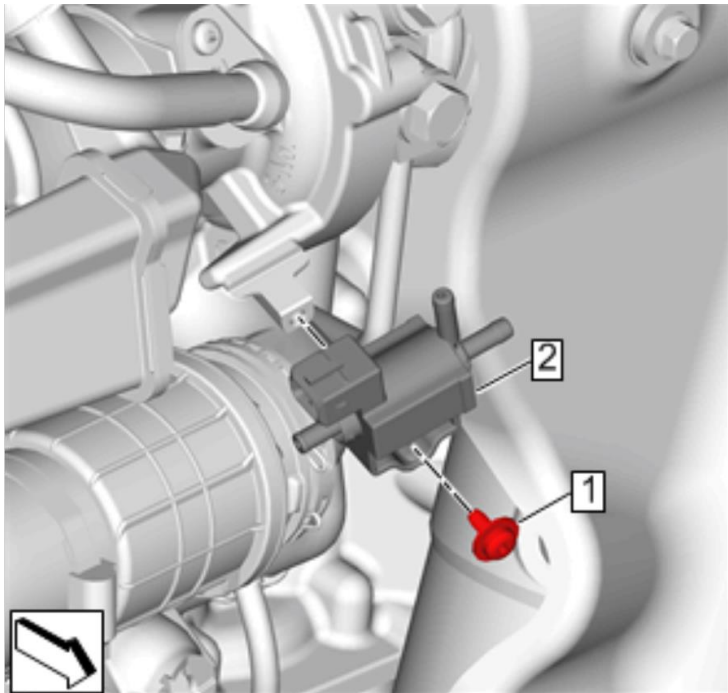

4823346

1. Remove the turbocharger wastegate regulator solenoid valve (TCV) (2). Refer to Turbocharger Wastegate Regulator Solenoid Valve Replacement in SI.
2. Drain the TCV by turning the valve upside down.

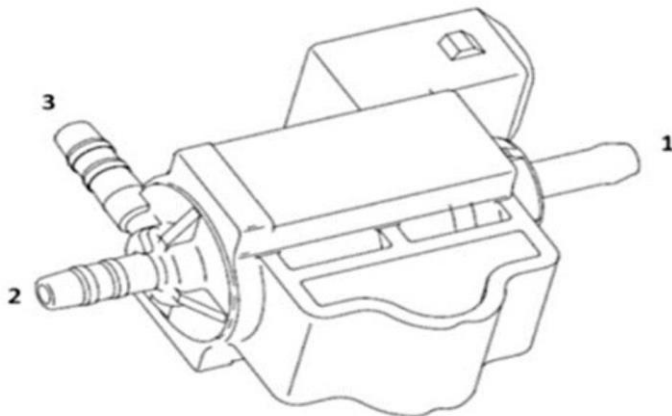

6055068

Note: Check port #2 to assure the spring gets lifted off the seat. This will be determined by the compressed air not dead heading when applied to port #2. When applying air to this port, a small amount of air should be observed at port #3 and even less air will be noticed at port #1. If this does not happen, the TCV plunger may have hardened deposits from hot operating conditions which will impede TCV plunger movement, and the TCV should be replaced.

3. Using clean shop air regulated to 80-100 PSI, blow through all three ports (1, 2 & 3) for 5 seconds each.
 - Repeat step 3 twice.

Service Update

N222372590 Charge Air Cooler Icing

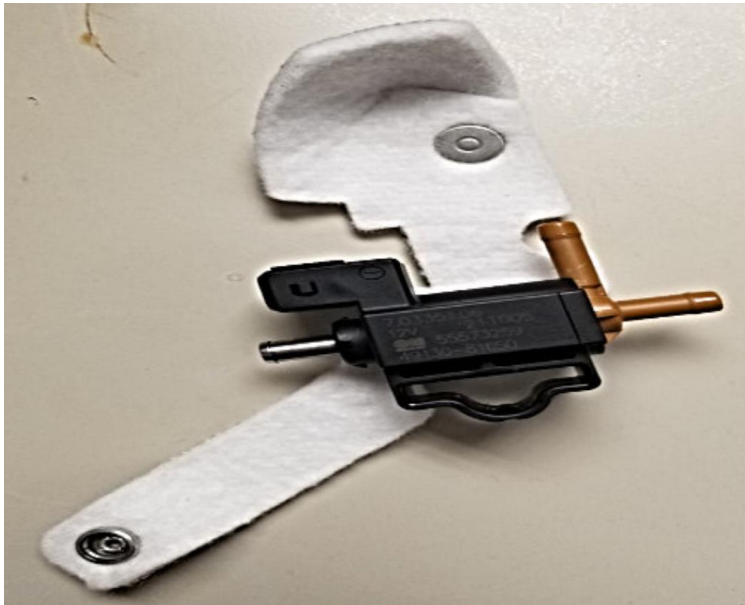

6055077

4. Prior to reinstalling the TCV, pre-position the thermal wrap. This will aid in installation of the wrap once the TCV is reinstalled.



6046314

Note: The end result of the wrap will surround the TCV as shown in the graphic above.

5. Install the TCV. Refer to Turbocharger Wastegate Regulator Solenoid Valve Replacement in SI.

Service Update

N222372590 Charge Air Cooler Icing



6046334

6. Once the mounting bolt and hoses are properly installed, pull the lower portion of the wrap upward and snap it into position.
7. For Chevrolet Equinox and GMC Terrain WITHOUT RPO LTG, and all other vehicles model year 2018 and newer, proceed to the next step for programming.
 - For all other vehicles prior to model year 2018, or Equinox/Terrain equipped WITH RPO LTG, do not reprogram the ECM. Simply hook up the MDI or MDI2 and clear all DTCs from the vehicle.

Note: Carefully read and follow the instructions below.

- Ensure the programming tool is equipped with the latest software and is securely connected to the data link connector. If there is an interruption during programming, programming failure or control module damage may occur.
- Stable battery voltage is critical during programming. Any fluctuation, spiking, over voltage or loss of voltage will interrupt programming. Install a GM Authorized Programming Support Tool to maintain system voltage. Refer to www.gmdesolutions.com for further information. If not available, connect a fully charged 12 V jumper or booster pack disconnected from the AC voltage supply. DO NOT connect a battery charger.
- Follow the on-screen prompts regarding ignition power mode, but ensure that anything that drains excessive power (exterior lights, HVAC blower motor, etc) is off.
- Clear DTCs after programming is complete. Clearing powertrain DTCs will set the Inspection/Maintenance (I/M) system status indicators to NO.

Important: The service technician always needs to verify that the VIN displayed in the TLC left side drop down menu and the top center window match the VIN plate of the vehicle to be programmed prior to using Service Programming System 2 (SPS2) for programming or reprogramming a module.

- For the TLC application, service technicians need to always ensure that the power mode (ignition) is “ON” before reading the VIN from the vehicle’s VIN master module and that they do not select a VIN that is already in the TLC application memory from a previous vehicle.
- If the VIN that shows up in the TLC top center window after correctly reading the VIN from the vehicle does not match the VIN plate of the vehicle, manually type in the VIN characters from the vehicle VIN plate into the TLC top center window and use these for programming or reprogramming the subject module with the correct vehicle VIN and software and/or calibrations.
- The Engine Control Module (ECM) is the master module (for VIP vehicles) that TLC reads to determine the VIN of the vehicle. If the VIN read from the vehicle by TLC does not match the VIN plate of the vehicle, the ECM also needs to be reprogrammed with the correct VIN, software and calibrations that match the vehicle’s VIN plate.

Service Update

N222372590 Charge Air Cooler Icing



- The Body Control Module (BCM) is the master module (for GEM vehicles) that TLC reads to determine the VIN of the vehicle. If the VIN read from the vehicle by TLC does not match the VIN plate of the vehicle, the BCM also needs to be reprogrammed with the correct VIN, software and calibrations that match the vehicle's VIN plate.

Caution: Be sure the VIN selected in the drop down menu (1) is the same as the vehicle connected (2) before beginning programming.

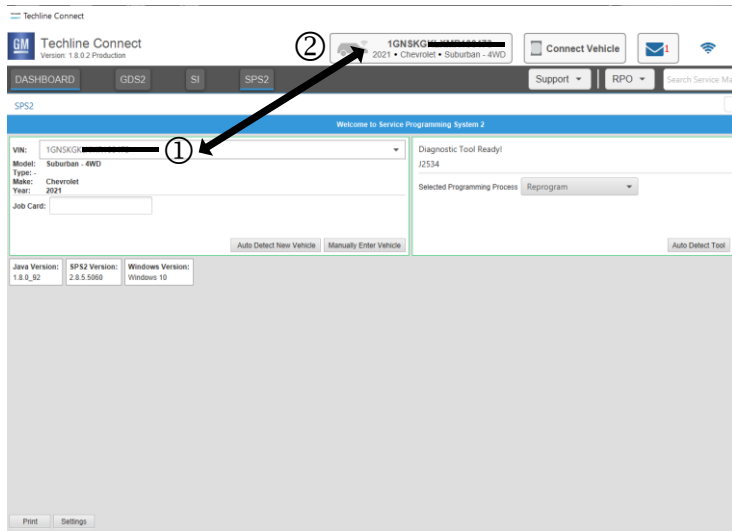

5743643

Important: If the vehicle VIN DOES NOT match, the message below will be shown.

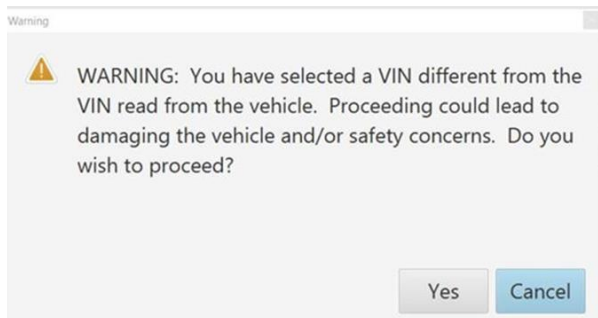

5877000

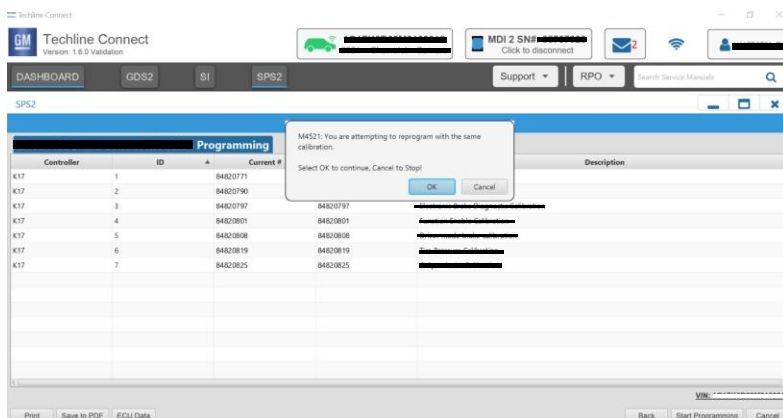

5644477

Important: Techline Connect screens shown above.

Important: If the same calibration/software warning is noted on the TLC Summary screen, select OK and follow screen instructions. After a successful programming event, the WCC is located in the Service Programming System dialogue box of the SPS Summary screen. No further action is required. Refer to the Warranty section of the bulletin.

- Reprogram the Engine Control Module (ECM) refer to *K20 Engine Control Module: Programming and Setup* in SI.

Service Update

N222372590 Charge Air Cooler Icing

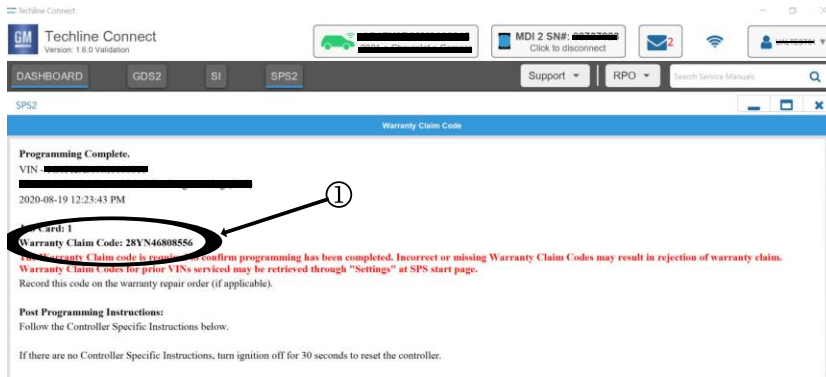

5644478

Note: The screenshot above is an example of module programming and may not be indicative of the specific module that is being programmed. Module selection and VIN information have been blacked out.

Important: To avoid warranty transaction rejections, you **MUST** record the warranty claim code provided on the Warranty Claim Code (WCC) screen shown above on the job card. Refer to callout 1 above for the location of the WCC on the screen.

9. Record SPS Warranty Claim Code on job card for warranty transaction submission.
10. Clear any DTCs present in the vehicle.

Dealer Responsibility

Dealers must take the steps necessary to ensure that the service update correction has been made to all involved vehicles before selling or dealer-trading the vehicle, but no later than June 30, 2024.

All new, used, GM Certified Used, courtesy transportation vehicles, dealer shuttle vehicles, etc. in dealers' possession and subject to this bulletin must be held and inspected/repaired per the service procedure of this bulletin before customers take possession of these vehicles. Involved vehicles must be held and not delivered to customers, dealer-traded, released to auction, used for demonstration, or any other purpose.

All GM Certified Used vehicles currently in the dealers' inventory within the Certified Pre-Owned Inventory System (CPOIS) will be de-certified and must be held and remedied per the service procedure in this bulletin. Upon submitting an accepted/paid warranty transaction in the Global Warranty Management (GWM) system, the vehicle can be re-certified for sale within the CPOIS system, or once again be used in the CTP program.

Dealer Reports – For USA & Export

The Inventory tab of the Open Vehicle Report will contain Service Update Bulletin VINs that apply to this field action. This information is intended to assist dealers with the **PROMPT COMPLETION** of these vehicles. The Customer In-Service tab will not contain Service Update Bulletin VIN data because the intent of a Service Update Bulletin is to not inconvenience a customer with a special trip for service. Service Update Bulletins are to be completed when the customer is in for a regularly scheduled visit.

