



QUALITY ACTION

CAMPAIGN BULLETIN

Manual Transmission

Reference: P2A19

Date: January 31, 2022

Attention: Dealer Principal, Sales, Service & Parts Managers

REVISED January 31, 2023
Please discard earlier versions of this bulletin.

The announcement from November 11, 2022 has been revised to include the following:

- The parts restriction will be removed on the following parts and dealers will be able to order, as needed, via normal ordering process beginning **February 7, 2023**:
 - 320B0-6GP0A Manual Transmission
 - 320B0-6GP0B Manual Transmission

Affected Models/Years:	Affected Population:	Dealer Inventory:	SERVICE COMM Activation date:	Stop Sale In Effect:
MY2023 Z (Z34), with manual transmission	174	16	October 5, 2022	YES

*******Dealer Announcement*******

Nissan is now updating the temporary Quality Assurance hold (PC922) on 174 specific model year 2023 Z vehicles identified in Service Comm to a dealer inventory quality action to replace the 6 speed manual transmission. Due to a manufacturing issue, which has since been corrected, the transmission may grind when shifting into second gear.

Affected vehicles are subject to stop sale and are either currently in dealer inventory or assigned and in transit to the dealer.

******* What Dealers Should Do *******

PLEASE FOLLOW THE ATTACHED INSTRUCTIONS:

1. Verify if vehicles are affected by this quality action using Service Comm or DBS National Service History – Open Campaigns I.D. **P2A19**
 - New vehicles in dealer inventory can also be identified using DBS (Sales-> Vehicle Inventory, and filter by Open Campaign).
 - Refer to NPSB 15-460 for additional information
 - **Some vehicles may still be in transit. Please continue to check newly arriving inventory for applicability.**

2. Please **do not drive, loan, sell or trade** the specific vehicles in dealer inventory subject to this quality action.
3. Use the attached procedure to remedy any vehicles affected by this quality action prior to sale.
4. The service department should submit the applicable warranty claim for the action performed to close the campaign in Service Comm and release the vehicle.

******* Dealer Responsibility *******

It is the dealer's responsibility to check Service Comm or DBS National Service History - Open Campaign using the appropriate campaign ID for the campaign status on each affected vehicle currently in new vehicle inventory.

NISSAN NORTH AMERICA, INC.

Total Customer Satisfaction

Revision History:

Date	Announcement	Purpose
November 11, 2022	Quality Action	New Campaign Announcement
January 31, 2023	REVISION 1	Parts restriction lifted



P2A19 2023 Z MANUAL TRANSMISSION

SERVICE PROCEDURE:

WARNING

Transmission and exhaust components will be hot just after the engine stops, use caution when performing repairs to prevent personal injury.

1. Position the vehicle in a stall with a vehicle lift and set the lift arms. (Figure 1)



Figure 1

2. Open the hood.

3. Raise the vehicle up several inches.
 - Open the driver's door
 - Verify the transmission is in the Neutral position
 - Verify the parking brake is released (down)

4. Drain the transmission fluid. (Figure 2)
 - Using a 10mm hex socket, loosen the transmission case drain plug
 - Drain the transmission fluid into a suitable container

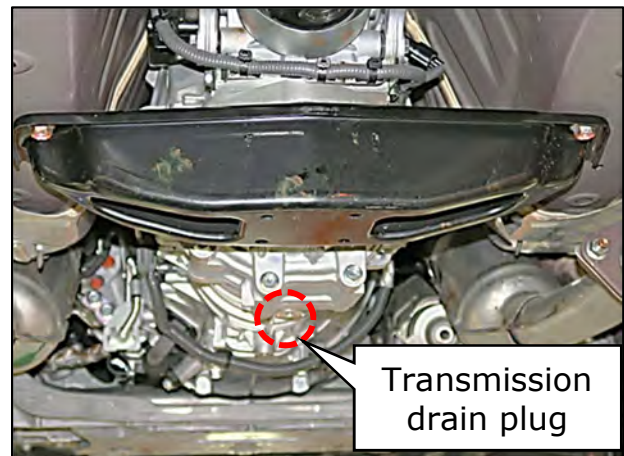

Figure 2

5. Remove the (2) nuts from the center exhaust tube flange. (Figure 3)

NOTE: These Nuts will be reused.

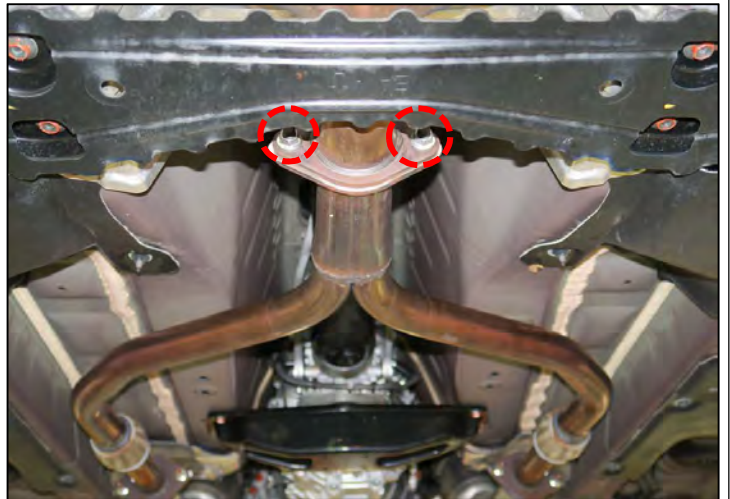

Figure 3

6. Remove the (4) nuts from the muffler assembly. (Figure 4)

NOTE: These Nuts will be reused.



Figure 4

7. Remove the (2) nuts from the (2) exhaust mounting brackets. (Figure 5)



Figure 5

8. Remove the center muffler (rear exhaust tube). (Figure 6)
- Separate the rear exhaust tube from the muffler and lower downward
 - Slide the rear exhaust tube out of the vehicle
 - Remove and discard the (3) gaskets from the rear exhaust tube



Figure 6

9. Remove the (4) nuts from the front exhaust tubes. (Figure 7)
- Discard these nuts, NEW nuts will be used during reassembly



Figure 7

10. Remove the front exhaust tube assembly. (Figure 8)
- Remove and discard the (2) gaskets from the catalytic converter



Figure 8

11. Remove the (4) bolts from the rear suspension member and the (2) heat insulator (heat shield) bolts. (Figure 9)

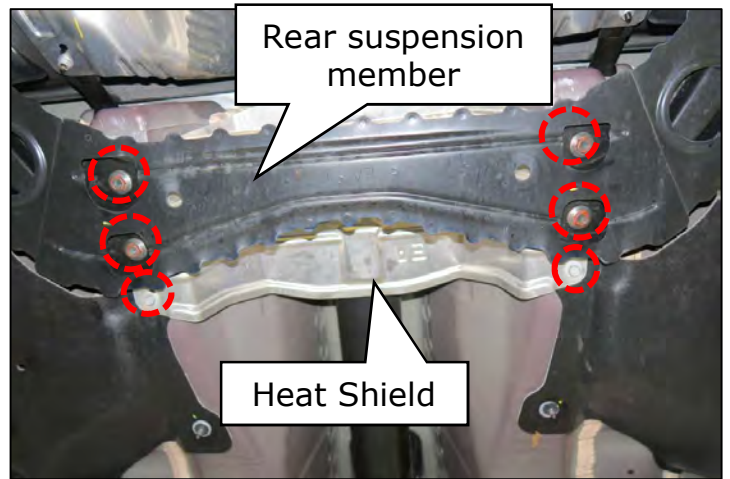

Figure 9

12. Remove the heat shield. (Figure 10)

- Pull downward on the suspension member and slide the heat shield toward the front of the vehicle to remove.

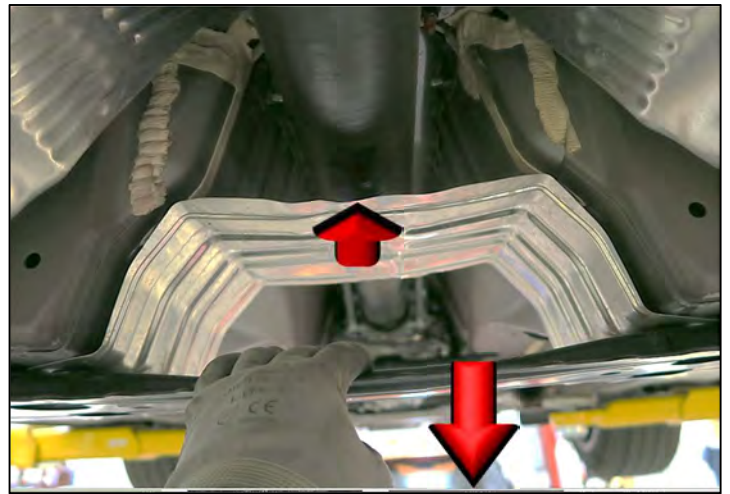

Figure 10

13. Using a paint marker, place an alignment mark on the rear differential flange and the propeller shaft flange to assist with alignment of the propeller shaft during reassembly. (Figure 11)

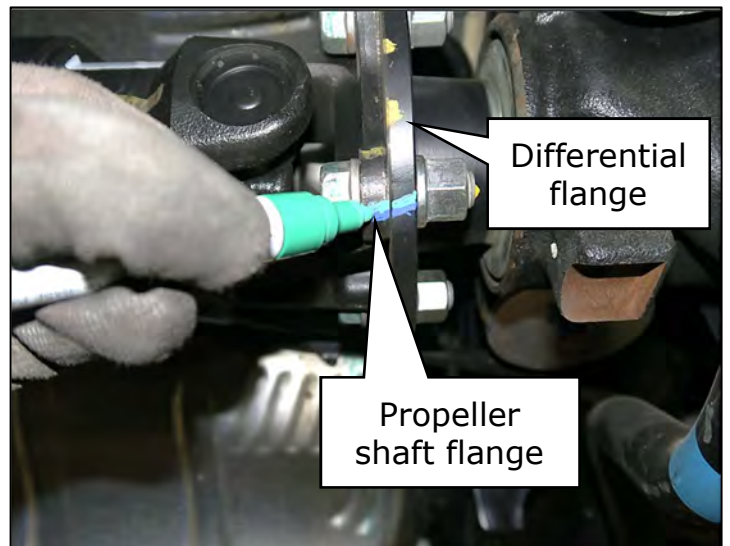

Figure 11

14. Using (2) 17mm wrenches, loosen and remove the (4) propeller shaft bolts and nuts. (Figure 12)

- Discard the propeller shaft nuts and bolts as NEW nuts and bolts will be installed during reassembly

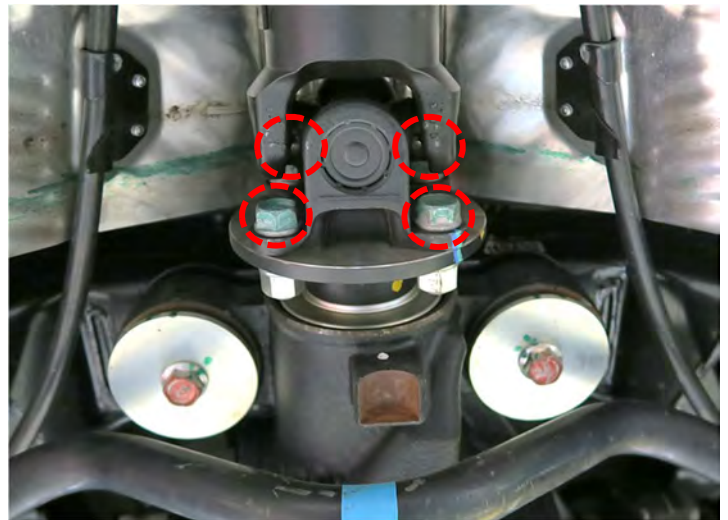

Figure 12

15. Separate the propeller shaft from the final drive (rear differential). (Figure 13)

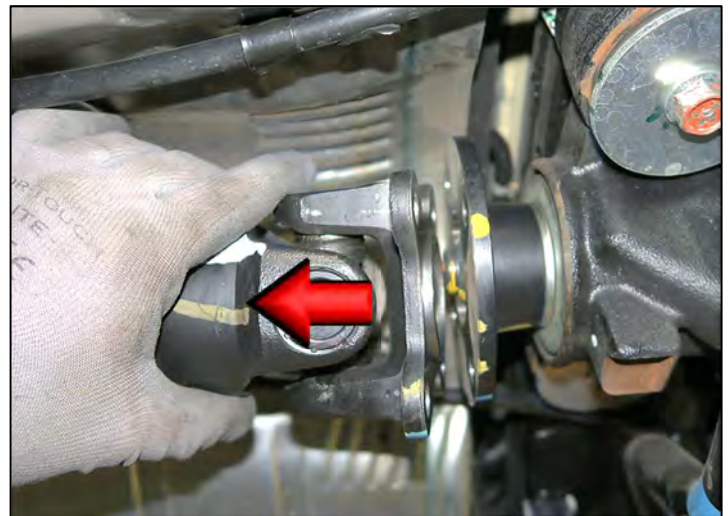

Figure 13

16. Remove the propeller shaft.

- Carefully slide the propeller shaft out of the transmission. (Figure 14)
- Place the propeller shaft in a safe area

NOTICE: Be careful when handling the propeller shaft. Do not drop the propeller shaft as damage may occur.



Figure 14

17. Disconnect the shifter assembly from the transmission. (Figure 15)
- Disengage the shift control rod boot
 - Remove the shift control rod bolt

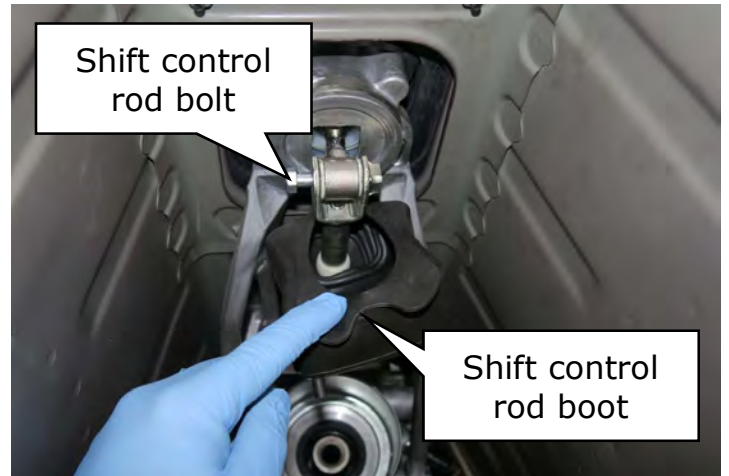

Figure 15

18. Lower the vehicle down.

19. Position the Driver's seat. (Figure 16)

- Open the LH front door.
- Move the LH seat forward fully
- Move the seat back to the fully forward position



Figure 16

20. Remove the (1) screw from the LH side of the center console. (Figure 17)

- Move the LH seat back to the original position



Figure 17

21. Position the passenger seat.
(Figure 18)

- Open the RH front door.
- Move the RH seat forward fully
- Move the seat back to the fully forward position



Figure 18

22. Remove the (1) screw from the RH side of the center console. (Figure 19)

- Move the RH seat back to the original position



Figure 19

23. Open the center console lid by depressing the button on the top of the console assembly. (Figure 20)

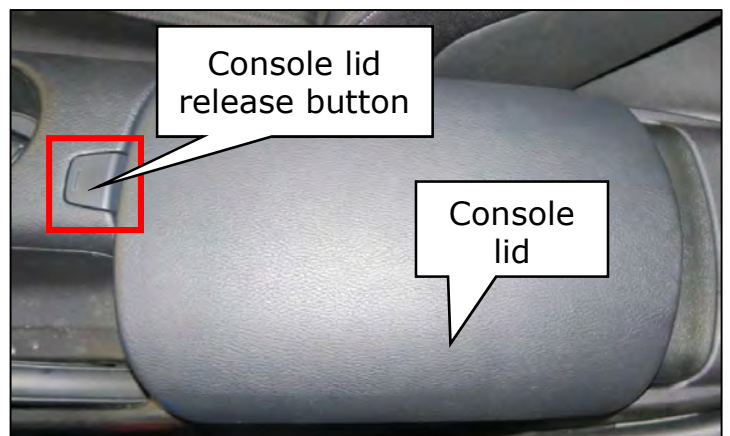

Figure 20

24. Remove the cup holder assembly.
(Figure 21)

- Carefully pull upward on the cup holder assembly to disengage the retainers
- Disconnect the electrical connector(s) from the cup holder assembly
- Depress the tangs on the harness retainer to disengage the harness from the cup holder assembly (Figure 22)
- Place the cup holder assembly in a safe area to avoid damage

NOTICE: Be careful to not scratch the interior components during removal.



Figure 21

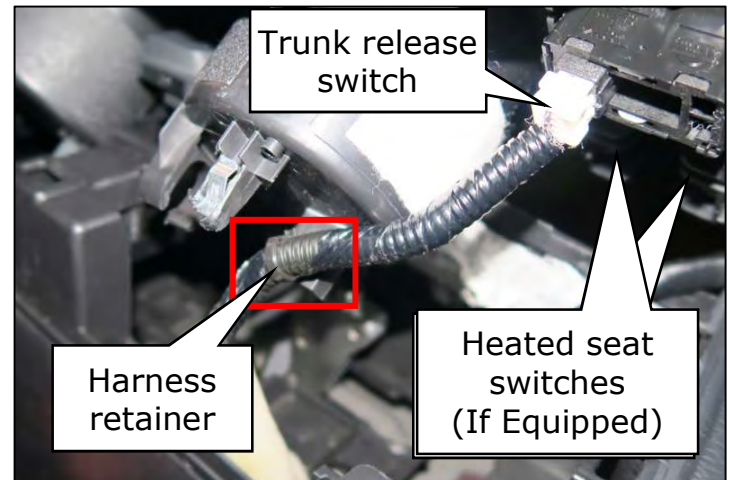

Figure 22

25. Remove the front tray finisher mat.
(Figure 23)



Figure 23

26. Remove the shifter finisher.

- Using a finesse stick, disengage the clips in order 1-6 as shown in Figure 24

NOTICE: Be careful to not scratch the interior components during removal.

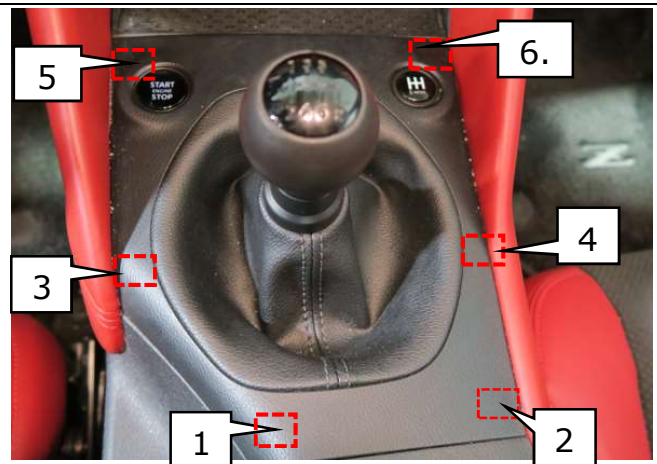

Figure 24

27. Lift the shifter finisher upward and disconnect the ignition button and the sport mode switch (if equipped). (Figure 25)

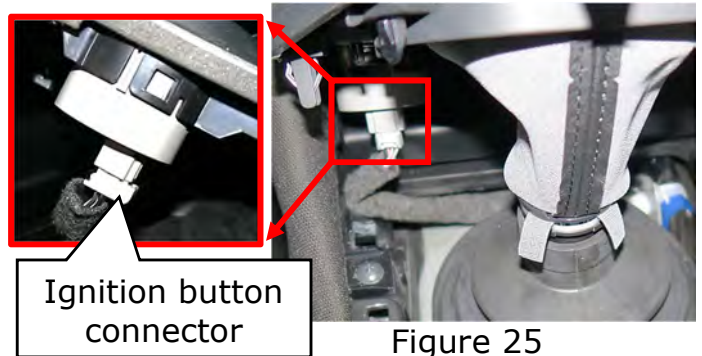

Figure 25

28. Detach the leather shift boot from the shifter finisher.

- a) Hold the shifter finisher upward
- b) Remove the (4) screw shown in Figure 26
- c) Carefully push upward on each of the (4) tabs
- d) Rotate the shifter finisher over and pull the shift boot upward to remove
- e) Lower the shifter finisher down
- f) Raise the shift boot upward
- g) Remove the shift boot trim ring from the shift boot by lifting the shifter boot off of each of the trim ring pins (Figure 27)
- h) Remove the trim ring
- i) Remove the shifter finisher

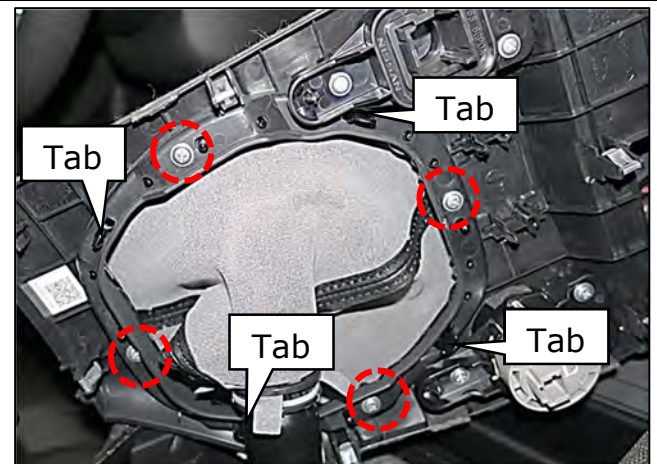

Figure 26

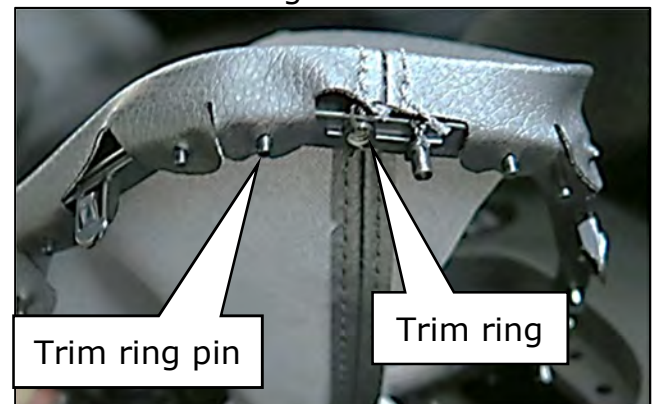

Figure 27

29. Remove the (2) screws from the console side finishers shown in Figure 28.

NOTICE: Be careful to not scratch the interior components during removal.

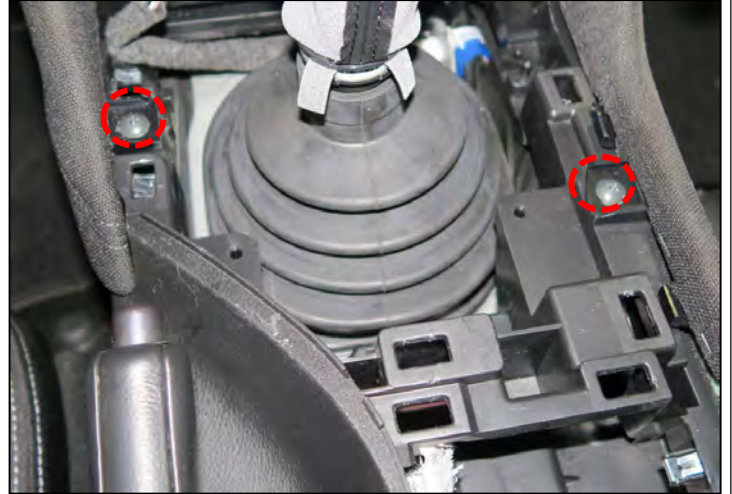

Figure 28

30. Remove both LH and RH console side finishers using a finesse stick. (Figure 29)

NOTICE: Be careful to not scratch the interior components during removal.

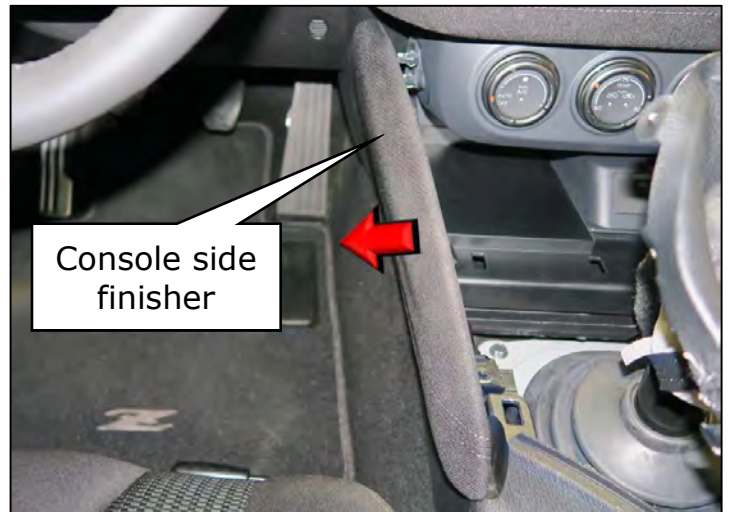

Figure 29

31. Disengage the USB finisher. (Figure 31)

- Remove the (1) screw from the RH side of the console tray (USB) finisher.
- Using a finesse stick, carefully pry rearward to disengage the USB finisher clips, but do not remove the USB finisher

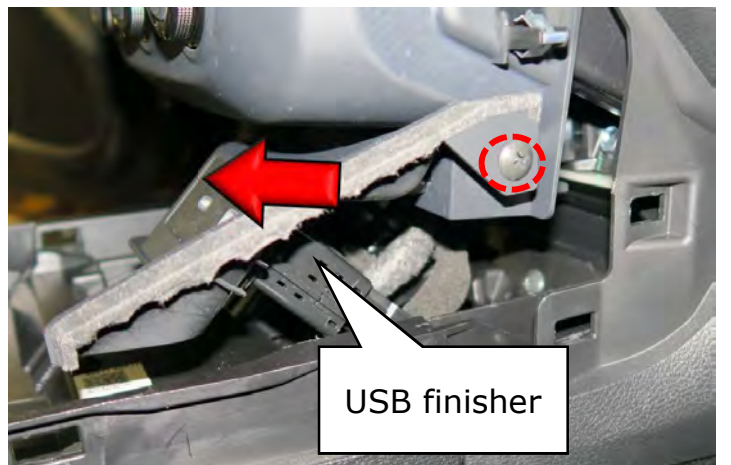

Figure 30

32. Remove the front tray finisher.
(Figure 31)

- Using a finesse stick, carefully pry upward to disengage the front tray finisher clips
- Remove the front tray finisher

NOTICE: Be careful to not scratch the interior components during removal.



Figure 31

33. Slide the USB finisher out of position and disconnect the (2) harness connectors. (Figure 32)

- Disconnect the harness connectors from the USB ports
- Remove the console tray finisher

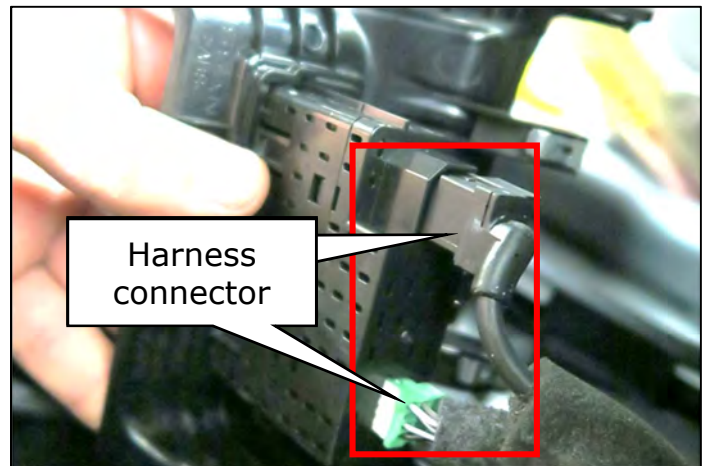

Figure 32

34. Remove the (2) screws from the front of the console finisher. (Figure 33)

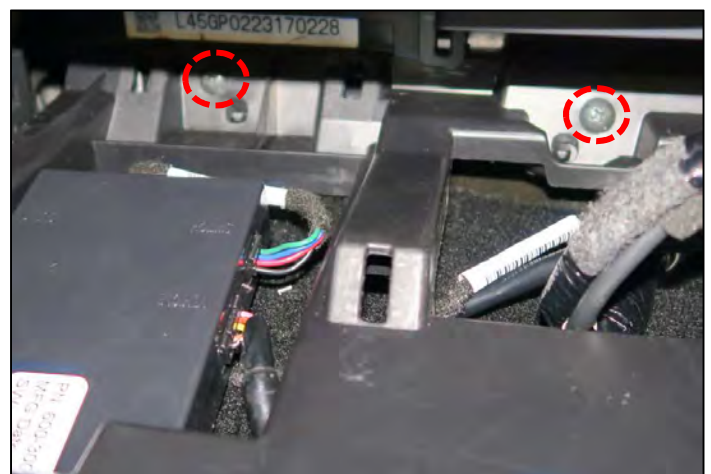

Figure 33

35. Disconnect the console electrical connector shown in Figure 34.

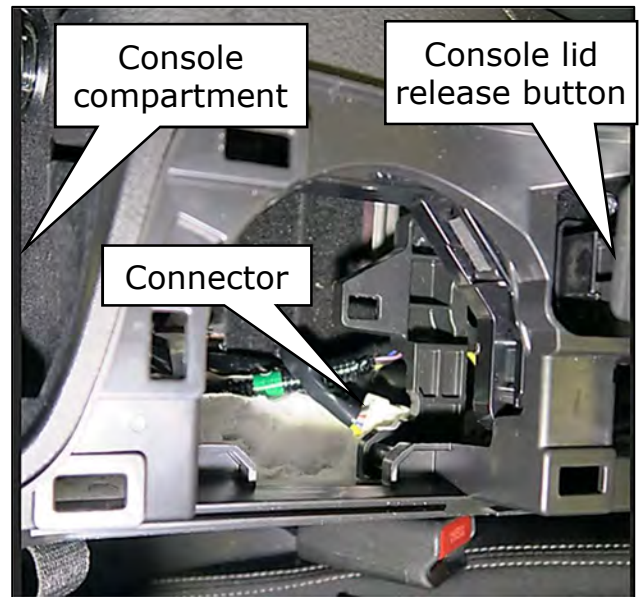

Figure 34

36. Pull the parking brake up.

- Using a deep well 10mm socket loosen the parking brake adjustment nut several turns (Figure 35)
- Pull the parking brake upward further to allow the console to be removed

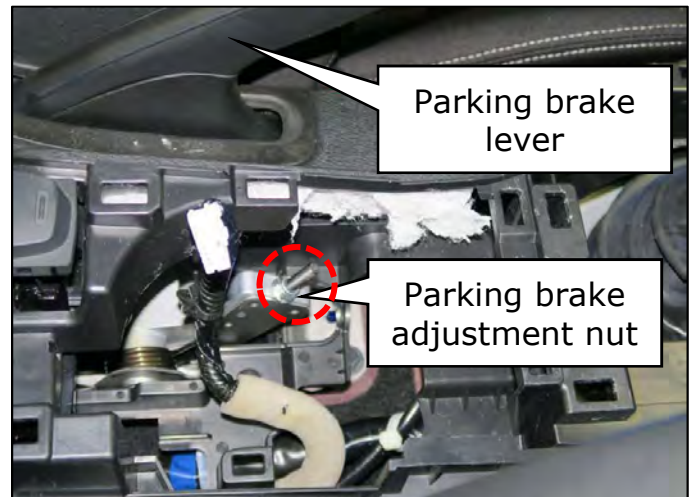

Figure 35

37. Remove the center console.

- Lift upward on the rear of the center console (Figure 36)
- Move the console toward the rear of the vehicle
- Carefully remove the center console from the vehicle out of the passenger door making sure to not scratch any of the interior trim



Figure 36

NOTICE: Be careful to not scratch the interior components during removal.

38. Disengage the (2) harness retainers from the hole cover. (Figure 37)

- Using a pair of pliers, depress the tabs of the harness retainers and remove the retainers from the hole cover.

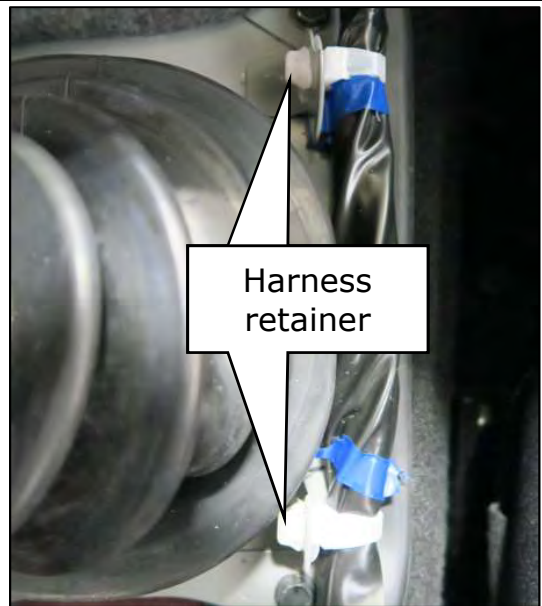

Figure 37

39. Remove the hole cover. (Figure 38)

- Remove the (4) bolts securing the hole cover to the floor.
- Lift upward on the hole cover and remove it from the vehicle

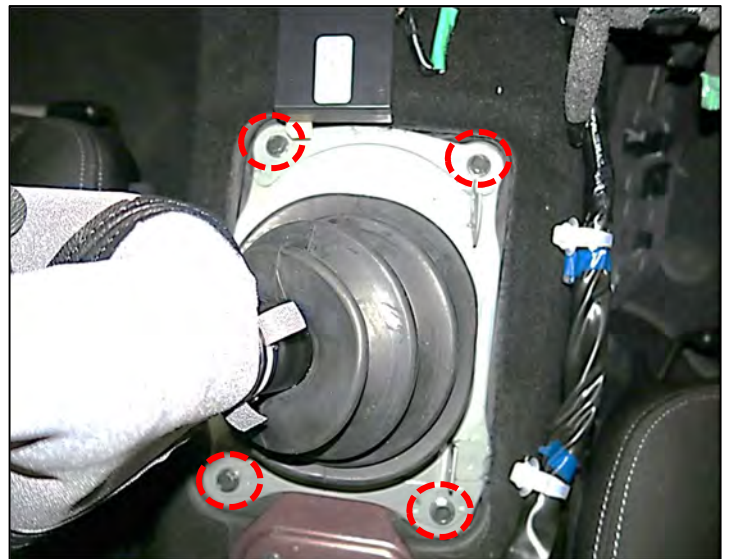

Figure 38

40. Remove the shifter assembly. (Figure 39)

- Lift the shifter guide plate boot up
- While pressing the guide plate downward, remove the (3) bolts securing it to the transmission

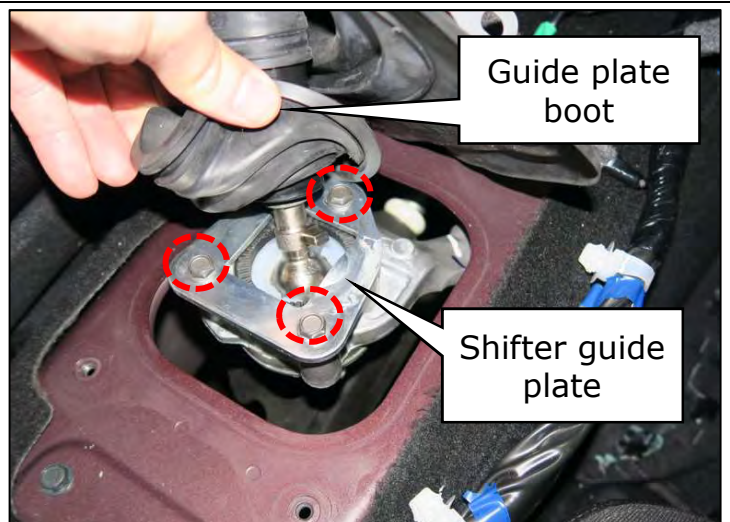

Figure 39

41. Lift the shifter out of the transmission bracket and place outside of the vehicle. (Figure 40)

- Remove the spring from the transmission assembly and place outside of the vehicle

NOTICE:

The shift rod assembly will contain grease, be careful to **NOT** transfer the grease to any of the interior components.

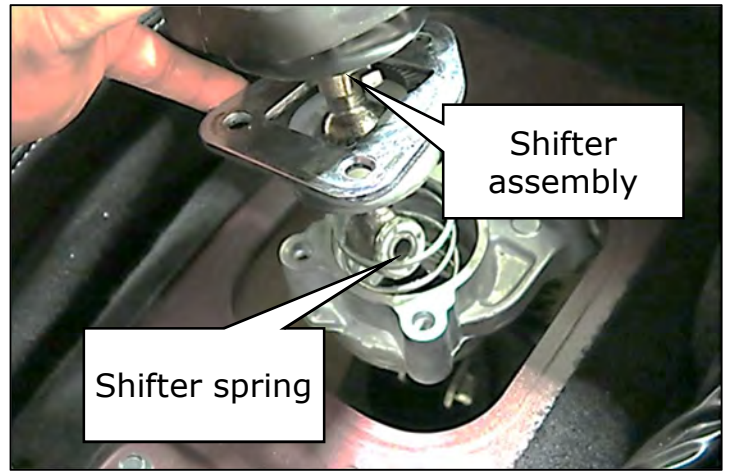

Figure 40

42. Disconnect the battery. (Figure 41)

- Close both doors
- Remove the battery cover
- Disconnect the negative battery cable.
- Place the battery cable next to the battery

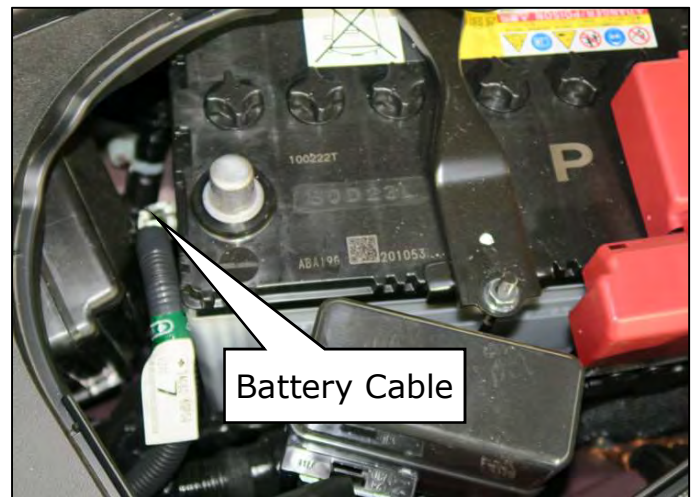

Figure 41

43. Raise the vehicle on a suitable lift.

44. Remove front suspension member stay. (Figure 42)

- Remove the (6) Nuts and washers, and the (2) bolts from the front suspension member stay.
- Remove the front suspension member stay from the vehicle

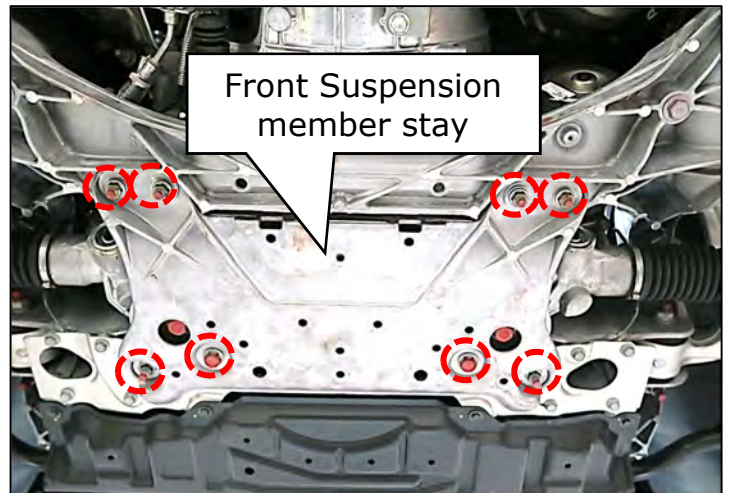

Figure 42

45. Remove the (4) 14mm engine side transmission shown in Figure 43.

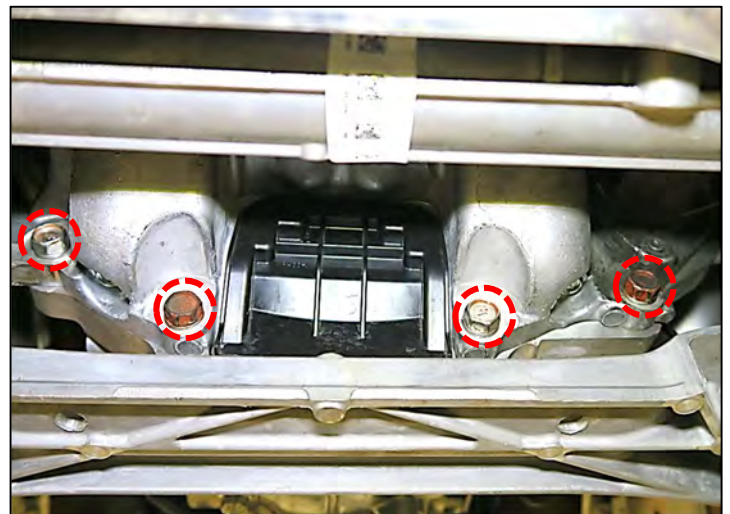

Figure 43

46. Remove rear plate cover. (Figure 44)

- Using a small flat blade screw driver or similar tool, release the retaining clips for the rear plate cover
- Remove the rear plate cover

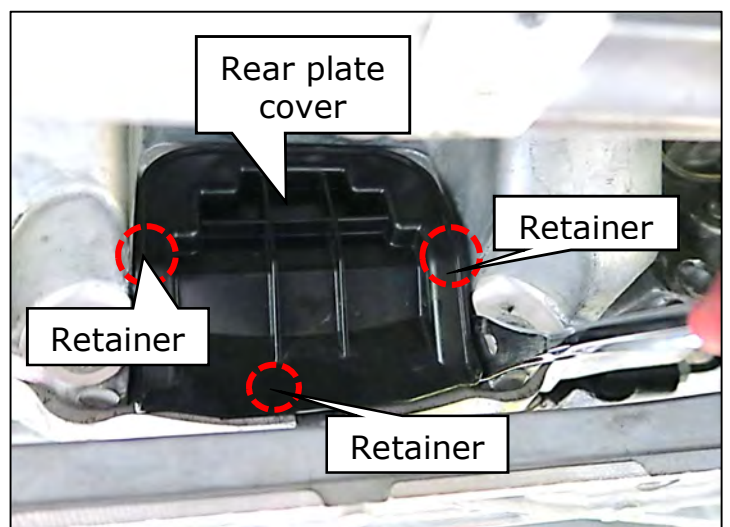

Figure 44

47. Remove the clutch operating cylinder. (Figure 45)

- Remove the 2 bolts from the clutch hydraulic line bracket
- Remove the 2 bolts from the clutch operating cylinder
- Allow the clutch operating cylinder to rest under the catalytic converter as shown in Figure 46

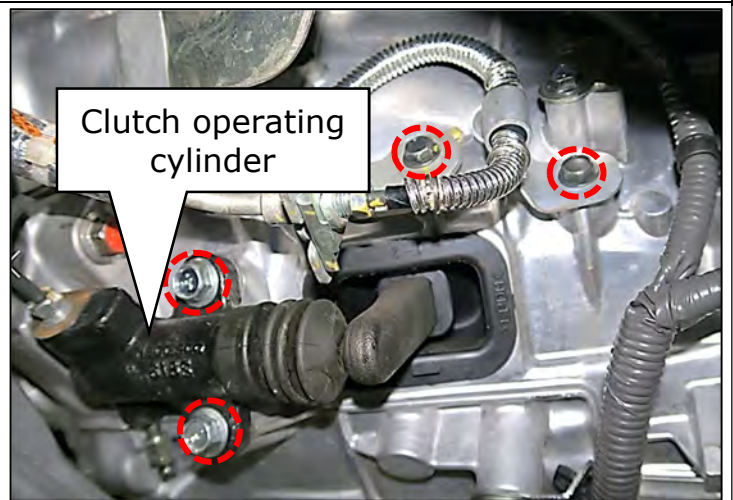

Figure 45

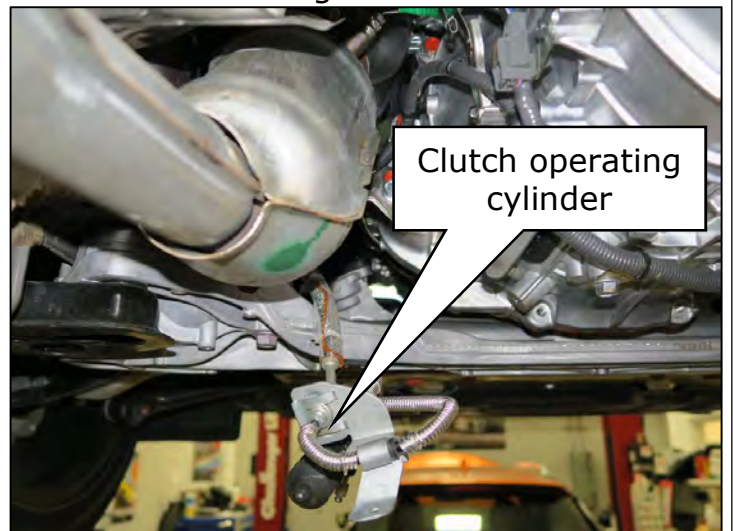

Figure 46

48. Remove the LH catalytic converter support bracket.

- Remove the (3) bolts shown in Figure 47

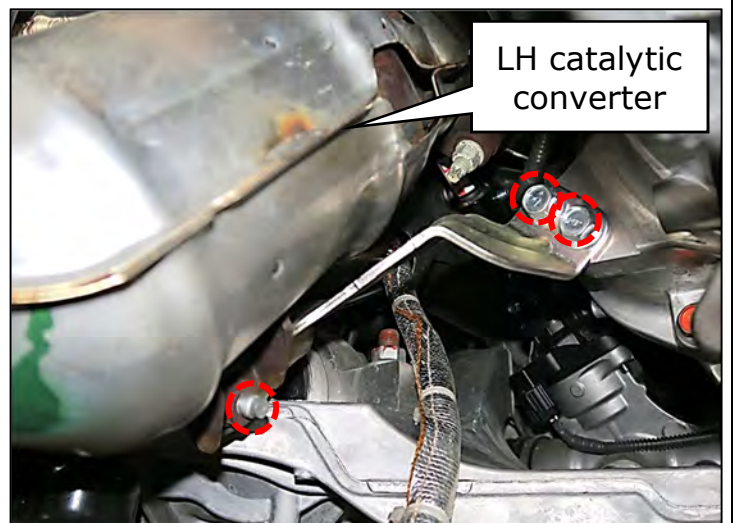

Figure 47

49. Disconnect the starter solenoid connector. (Figure 48)

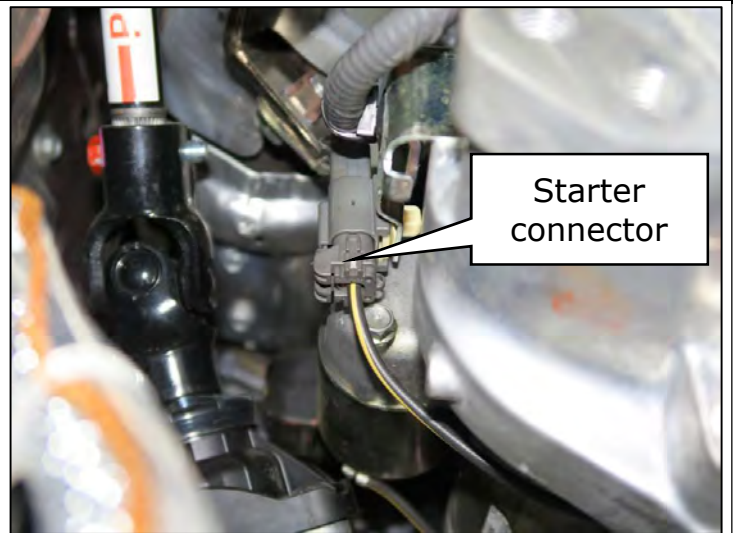

Figure 48

50. Disconnect the LH HO2S (rear O2 sensor) connector. (Figure 49)

- Remove the HO2S (rear O2 sensor) harness from the harness bracket

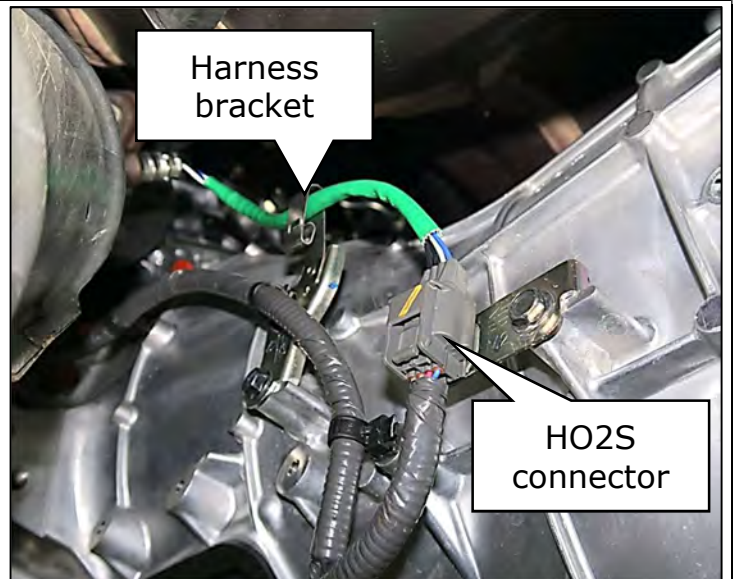

Figure 49

51. Remove the starter from the transmission.

- Remove the (2) starter bolts. (Figure 50)
- Move the starter motor toward the front of the vehicle and allow it to rest on the front suspension member

NOTE: The starter motor will remain in the vehicle.

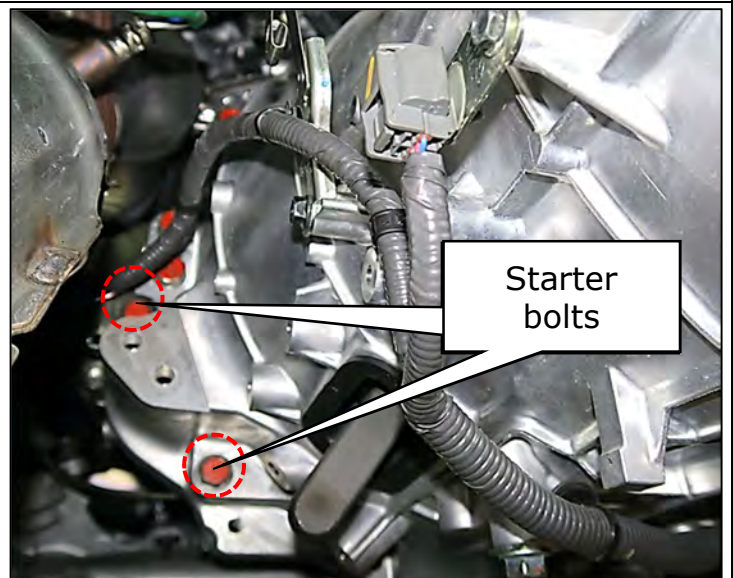

Figure 50

52. Remove the (2) harness retainer bolts and (2) harness retainers from the transmission case. (Figure 51)

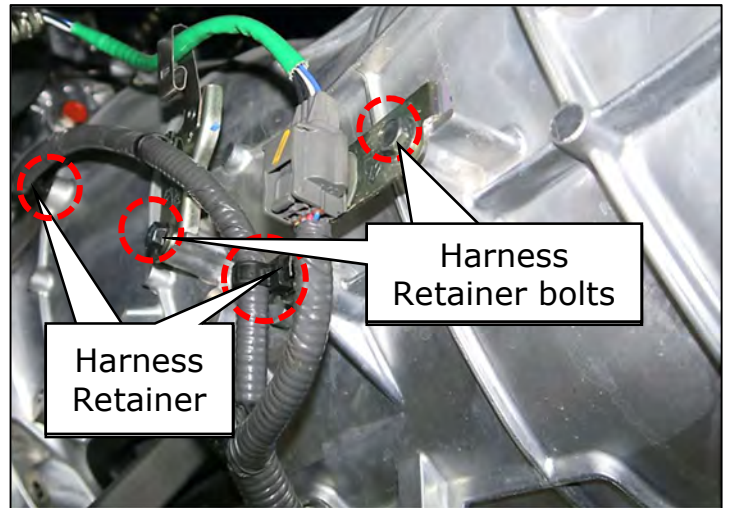

Figure 51

53. Remove the (2) harness retainer bolts from the bottom of the transmission assembly. (Figure 52)

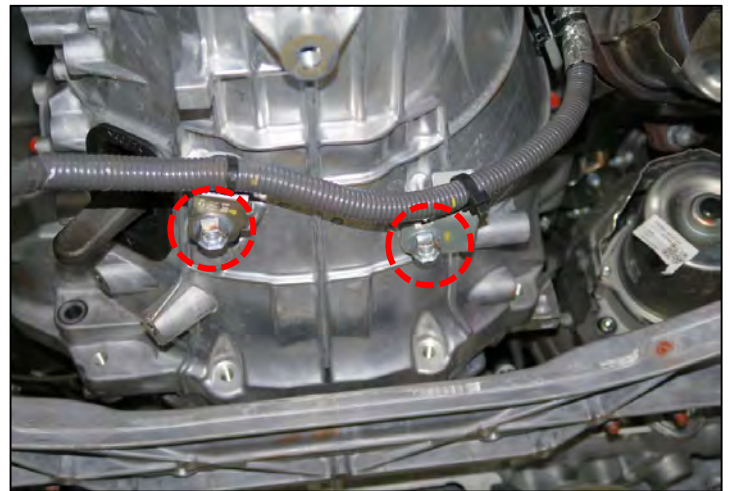

Figure 52

54. Position a suitable transmission jack under the transmission and secure it with a suitable strap. (Figure 53)

CAUTION

- To help avoid injury and/or part damage, verify the transmission is properly secured to the transmission jack to prevent the transmission from falling.

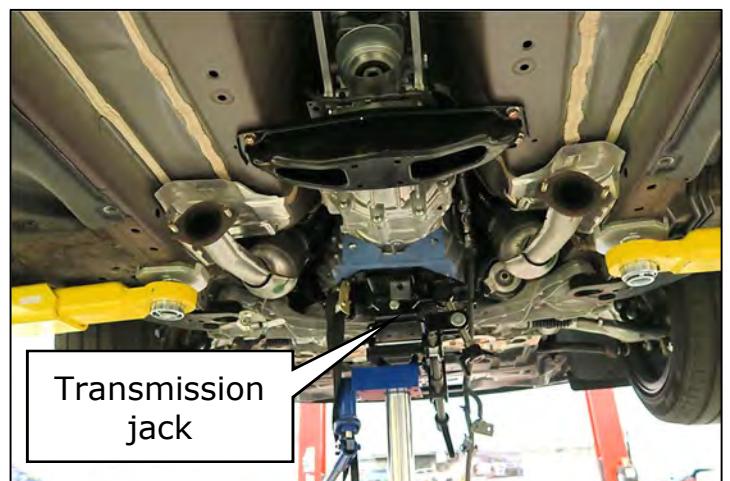

Figure 53

55. Remove the transmission cross-member. (Figure 54)

- Remove the (2) nuts securing the transmission cross-member to the rear engine mount (transmission mount)
- Remove the (4) bolts securing the cross-member to the vehicle frame rails
- Remove the cross-member from the vehicle

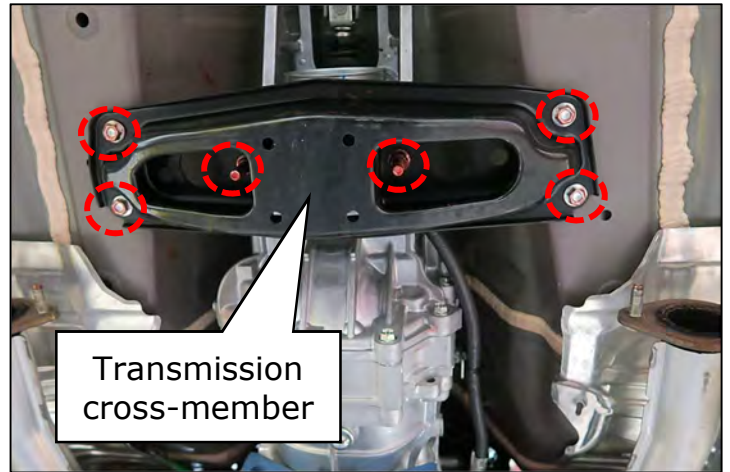

Figure 54

56. Remove the transmission mount.

- Remove the (2) bolts from the transmission mount. (Figure 55)
- Remove the transmission mount

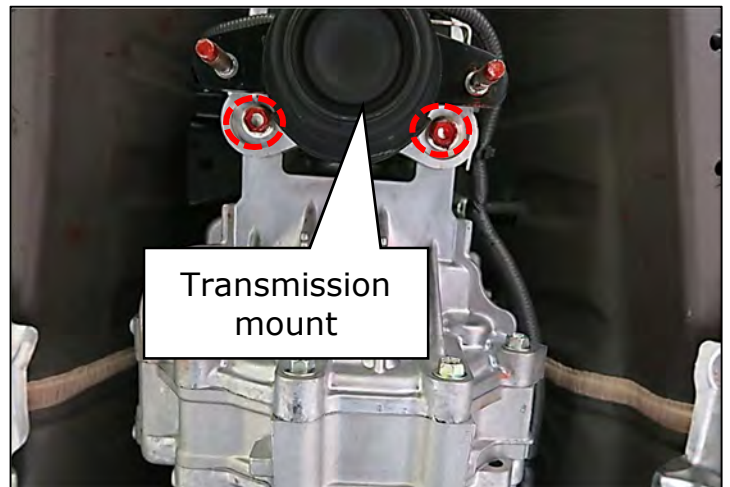

Figure 55

57. Lower the transmission down 4-6 inches to allow access to the remaining harness connectors, retainers and the bell housing bolts. (Figure 56)

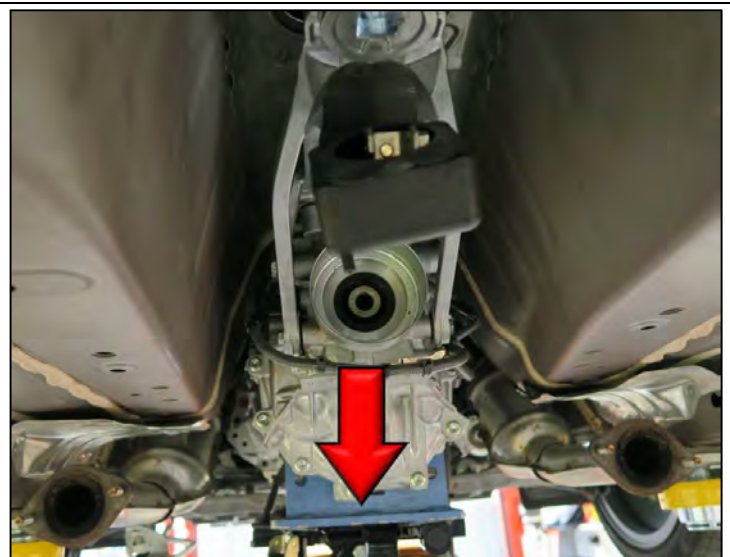

Figure 56

58. Disconnect the connector shown in Figure 57 and Figure 58.

- Depress the (2) tabs on the harness retainer to release it from the harness bracket

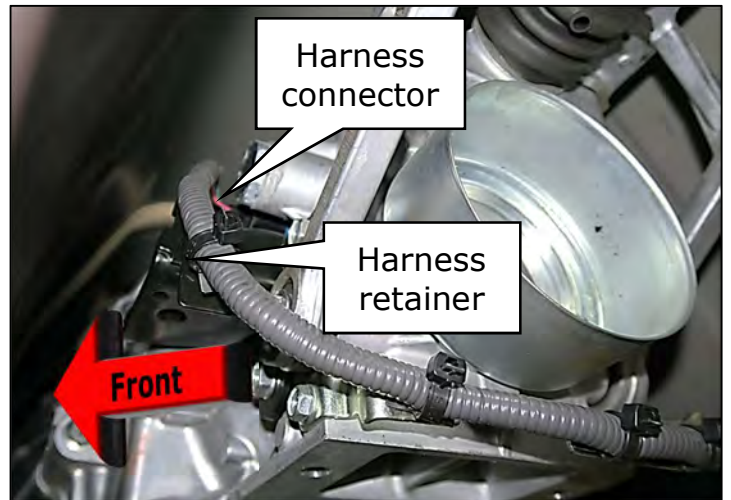

Figure 57

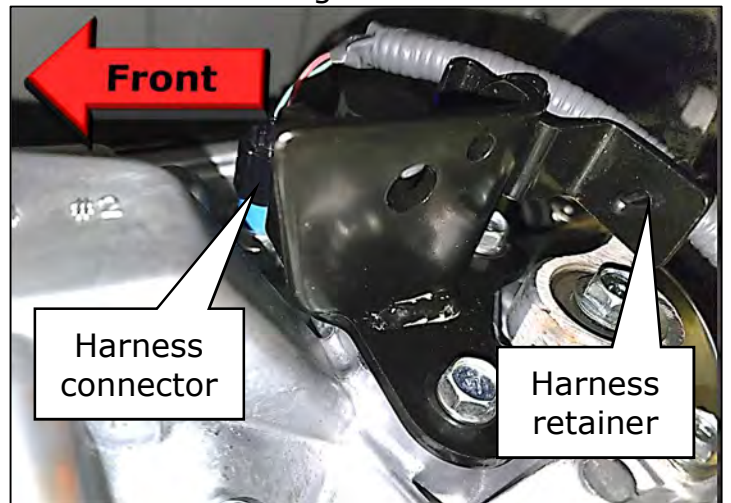

Figure 58

59. Remove the bolt securing harness retainer bracket shown in Figure 59.



Figure 59

60. Disconnect the harness connector shown in Figure 60.

- Remove the (2) bolts from the harness retainer brackets

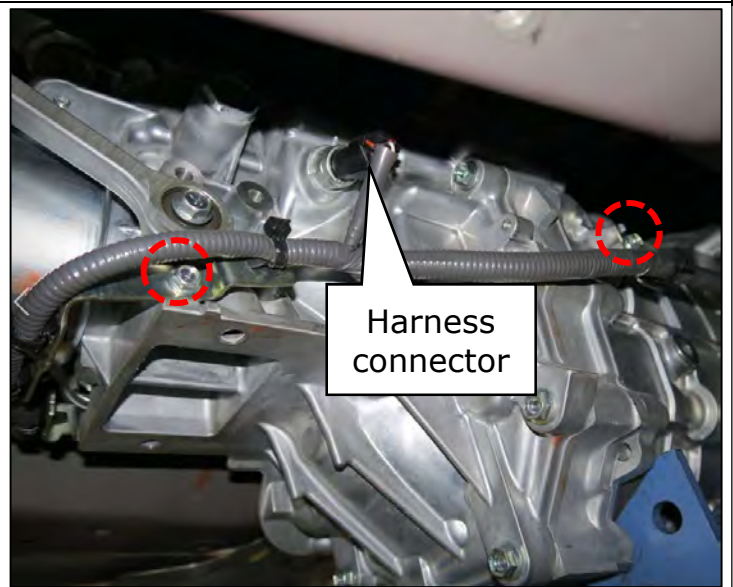

Figure 60

61. Disconnect the (2) bolts shown in Figure 61 securing the harness retainer bracket. (Figure 61)



Figure 61

62. Remove the RH catalytic converter support bracket.

- Remove the (2) bellhousing bolts and (1) bolt securing the RH catalytic converter support bracket (Figure 62)
- Remove the support bracket from the vehicle

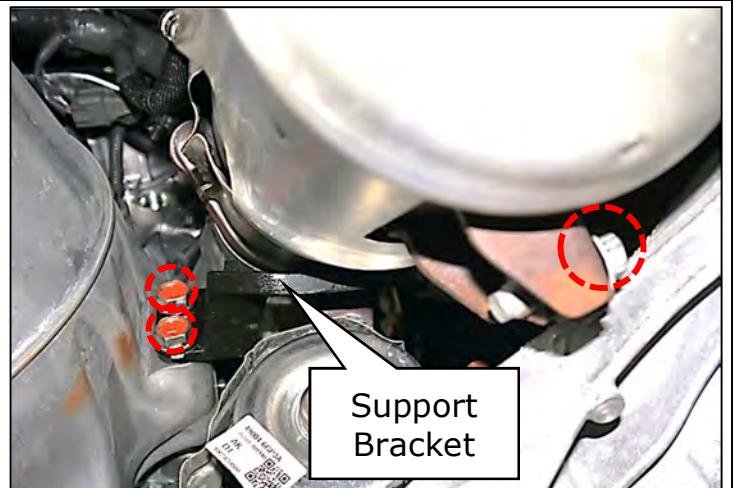

Figure 62

63. Route the harness over the catalytic converter as shown in Figure 63.

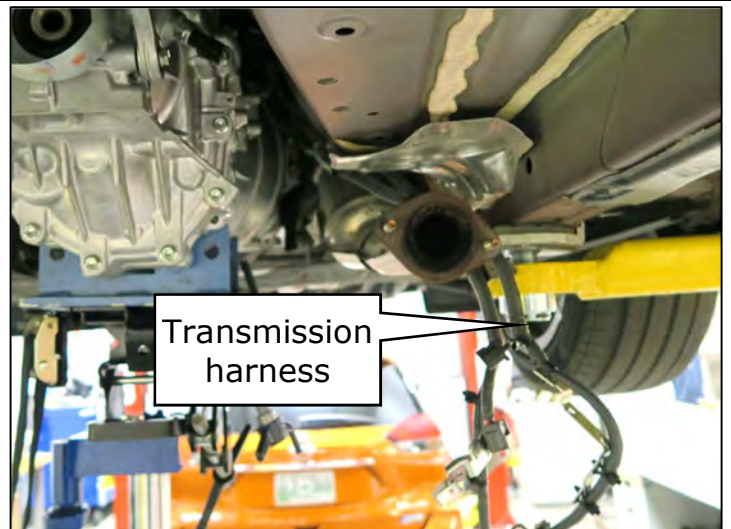

Figure 63

64. Disconnect the transmission breather hose. (Figure 64)

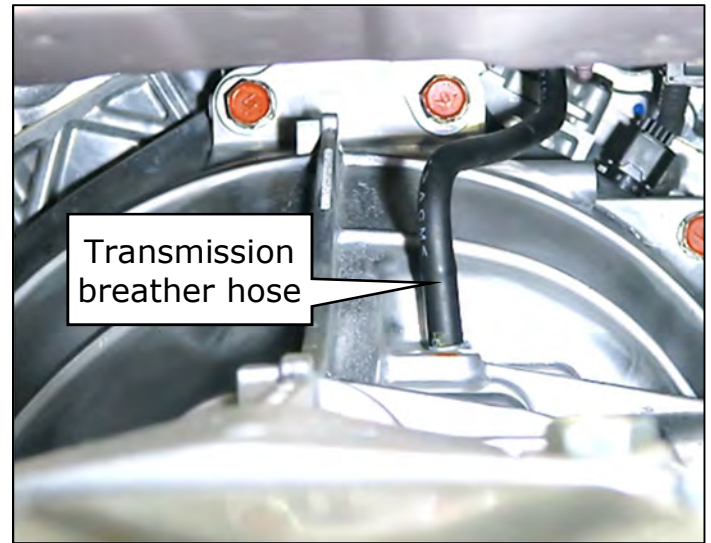

Figure 64

65. Remove the (4) upper transmission to engine mounting bolts. (Figure 65)

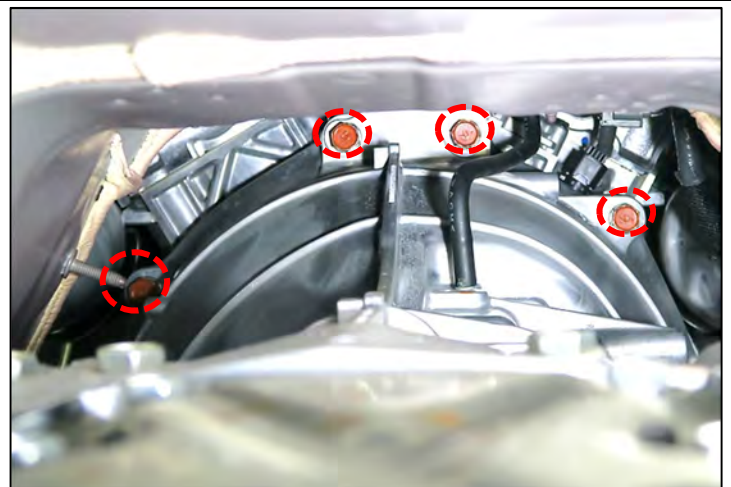

Figure 65

66. Remove the (2) remaining transmission to engine bolts on the LH side of the transmission. (Figure 66)



Figure 66

67. Using the transmission jack, raise the transmission until the transmission and engine are not touching the front member. (Figure 67)

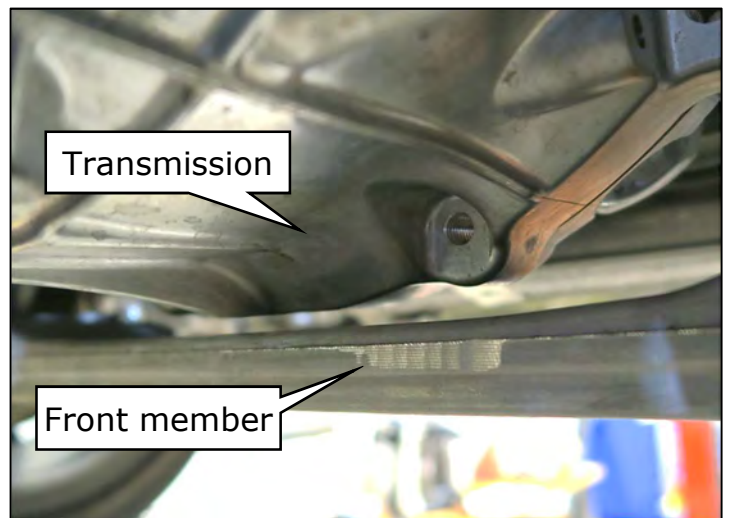

Figure 67

68. Remove the transmission.

- Using a pry bar, carefully separate the transmission from the engine
- Move the transmission toward the rear of the vehicle until the transmission bell housing is near the catalytic converter as shown in Figure 68
- Verify the input shaft of the transmission is clear of the clutch assembly

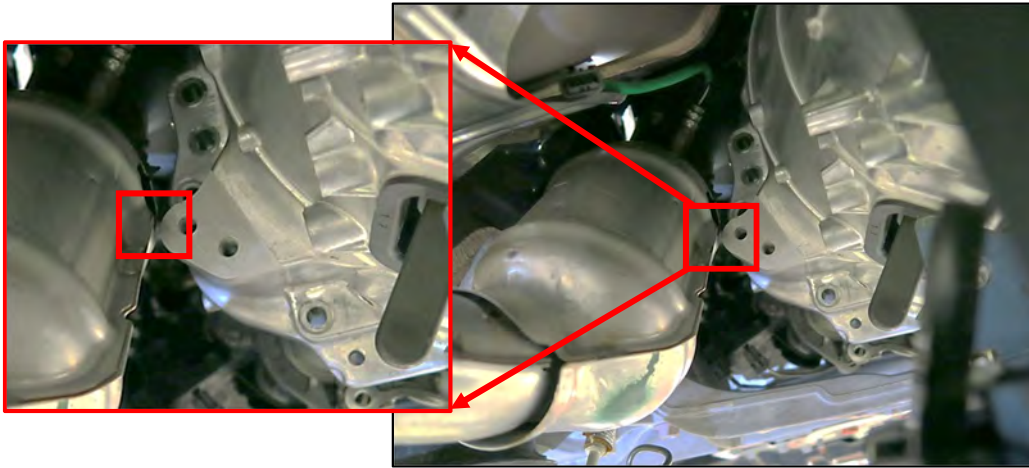

Figure 68

69. Carefully lower the transmission.
(Figure 69)



Figure 69

70. Using two people or a suitable hoist, remove the transmission from the transmission jack. (Figure 70)

- Using two people or a suitable hoist, position the NEW transmission onto the transmission jack and secure it with a suitable strap, making sure it is stable

CAUTION

- To help avoid injury and/or part damage:
- Do **NOT** attempt to lift the transmission alone.
- Verify the transmission is properly secured to the transmission jack to prevent the transmission from falling.

Reassembly:

71. Position the transmission under the vehicle. (Figure 70)

- Using the transmission jack, raise the transmission up a little at a time while moving the transmission toward the engine until the transmission input shaft is aligned with the center of the clutch disc
- Carefully push the transmission toward the front of the vehicle but do **NOT** seat the transmission

Important:

While lifting the transmission:

- Make sure the input shaft of the transmission does NOT contact the clutch pressure plate
- Make sure the bell housing does not contact with the catalytic converters



Figure 70

72. On the RH side of the transmission, reach up and position the harness and transmission breather tube bracket over the transmission case. (Figure 71)

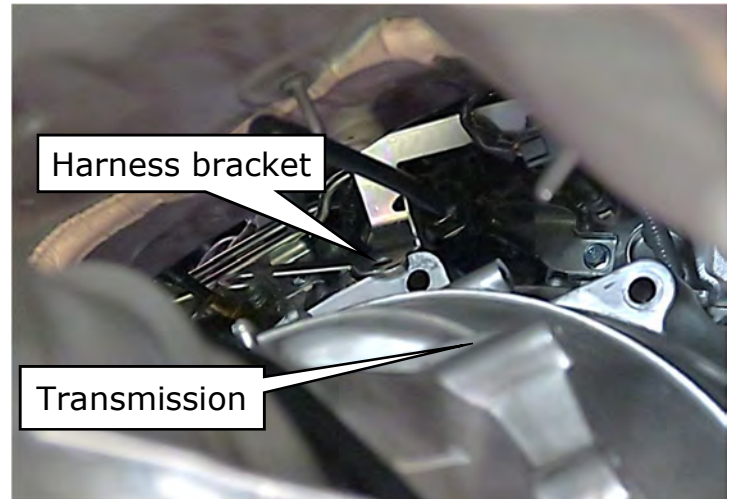

Figure 71

73. Push the transmission forward until the transmission case is flush against the engine. (Figure 72)

Important:

- **Do NOT** use the transmission bell housing bolts to seat the transmission to the engine. Doing so will cause damage to the clutch assembly.

NOTE:

To assist with aligning the engine and transmission, the engine position can be adjusted by pulling down or pushing upward on the catalytic converters.

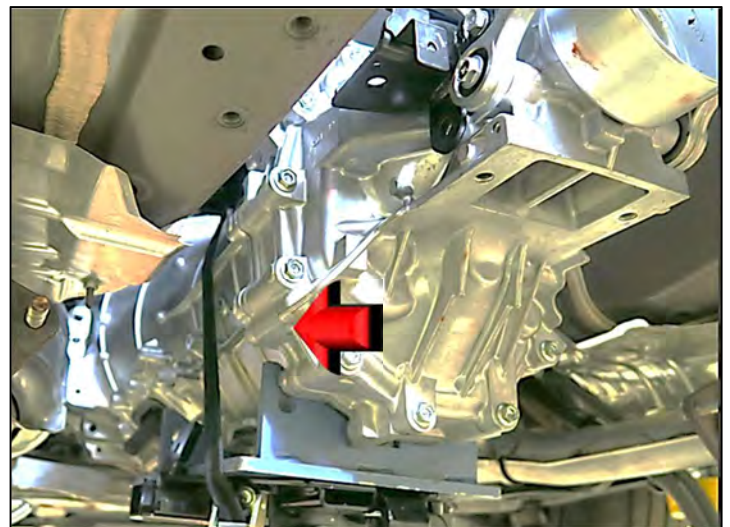

Figure 72

74. Once the transmission is flush against the engine, start the (3) LH (driver's side) bell housing bolts by hand. (Figure 73)

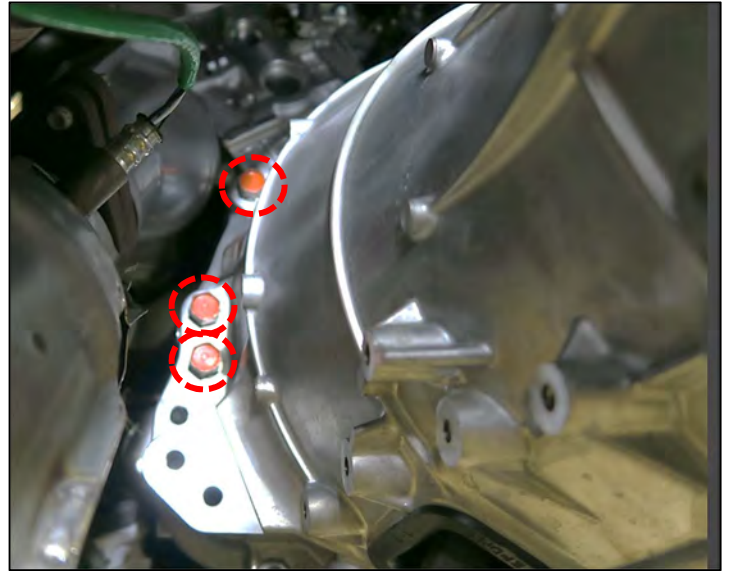

Figure 73

75. Install the RH catalytic converter support bracket and start the (2) bell housing bolts and the (1) catalytic converter bolt by hand. (Figure 74)

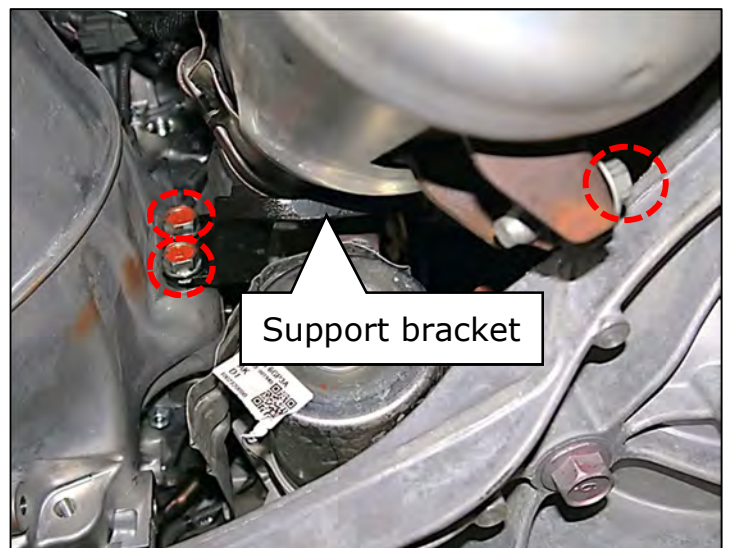

Figure 74

76. Reconnect the transmission breather hose. (Figure 75)

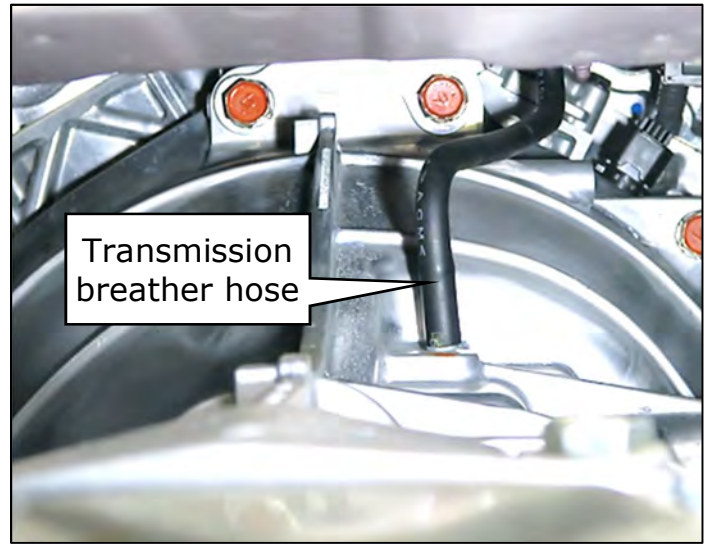

Figure 75

77. Start the (3) remaining upper transmission mounting bolts. (Figure 76)

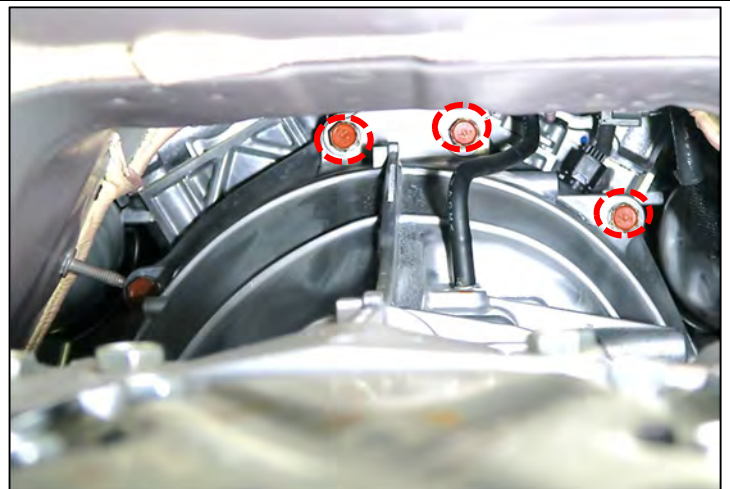

Figure 76

78. Torque all (8) of the transmissison side mounting bolts to 75 N•m(7.7 kg-m, **55 ft-lbs**).

79. Torque the RH catalytic converter support bracket bolt to 47.8 N•m(4.9 kg-m, **35 ft-lbs**). (Figure 77)

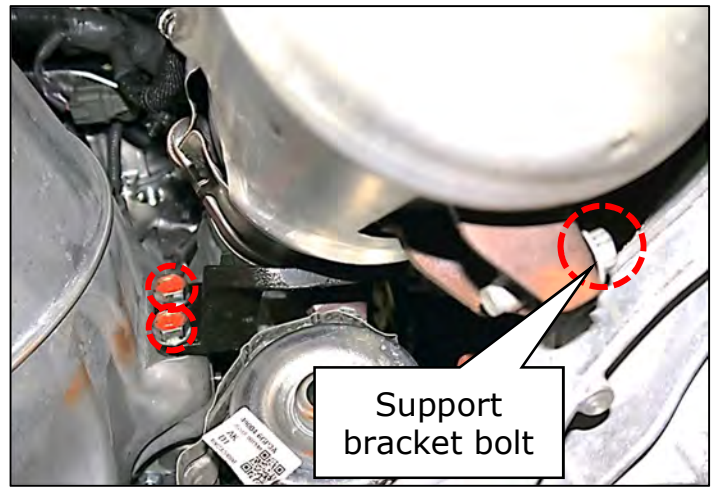

Figure 77

80. Reinstall the (4) engine side transmission bolts shown in Figure 78.

- Torque bolts to 46.6 N•m(4.8 kg-m, **34 ft-lbs**)
- Reinstall the rear plate cover

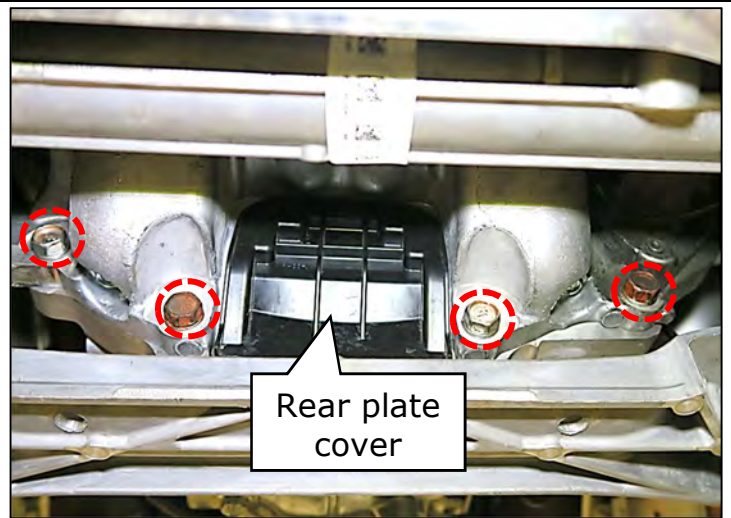

Figure 78

81. Move the wiring harness previously placed over the catalytic converter. (Figure 79)

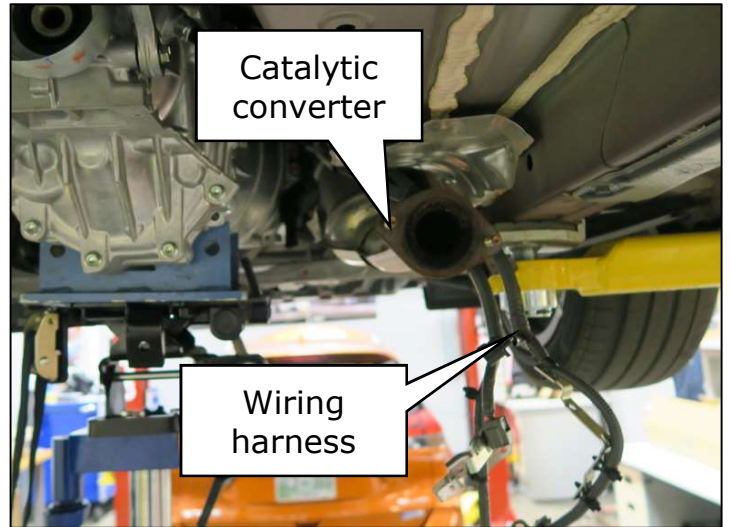

Figure 79

82. Remove the harness brackets

- Using a pair of pliers, depress the harness retainer tabs and remove the brackets shown in Figure 80.
- The new transmission will be equipped with these harness retainer brackets and bolts
- These harness retainer brackets are not needed and can be disposed



Figure 80

83. Route the rear section of the wiring harness as shown Figure 81.

- Connect the harness connector on the LH side
- Insert the harness retainers into the wiring harness retainer brackets shown in Figure 82

NOTE:

An audible click will be heard once the connector is fully seated.

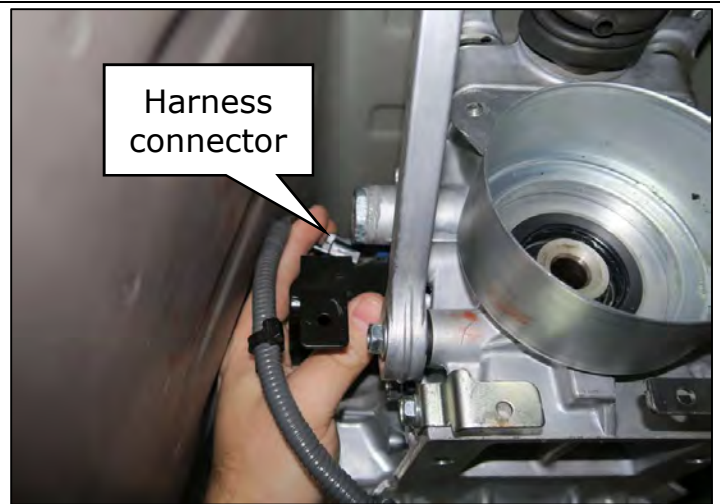

Figure 81

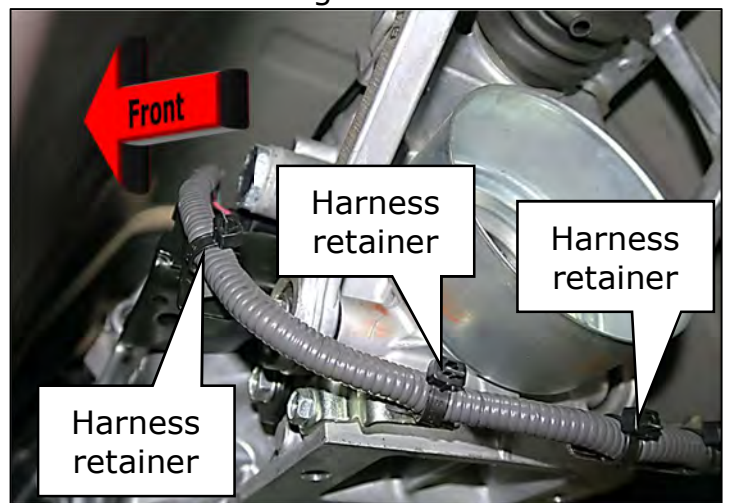

Figure 82

84. Connect the wire harness connector(s) and harness retainers on the RH side of the transmission shown in Figure 83.

NOTE:

An audible click will be heard once the connector is fully seated.

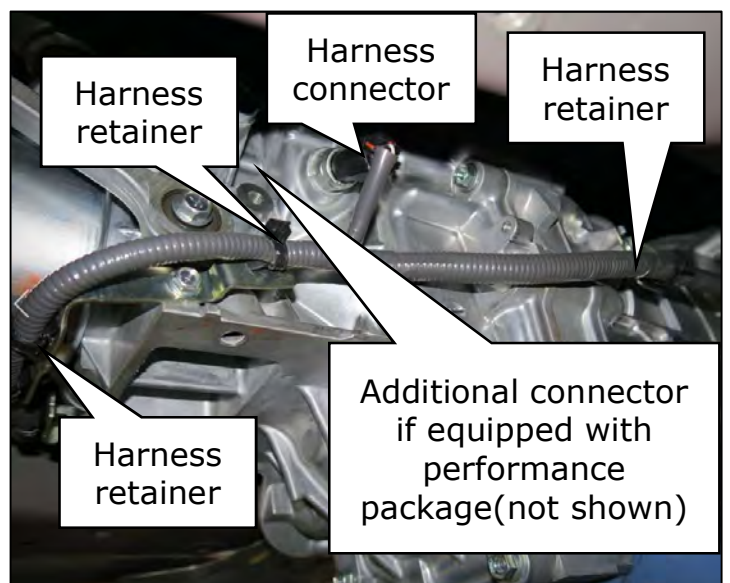

Figure 83

85. Install the (2) bolts on the harness retainer bracket that secures the harness to the transmission on the RH side of the transmission. (Figure 84)

- Torque the bolts to 7 N•m(0.71 kg-m, **62 in-lbs**)

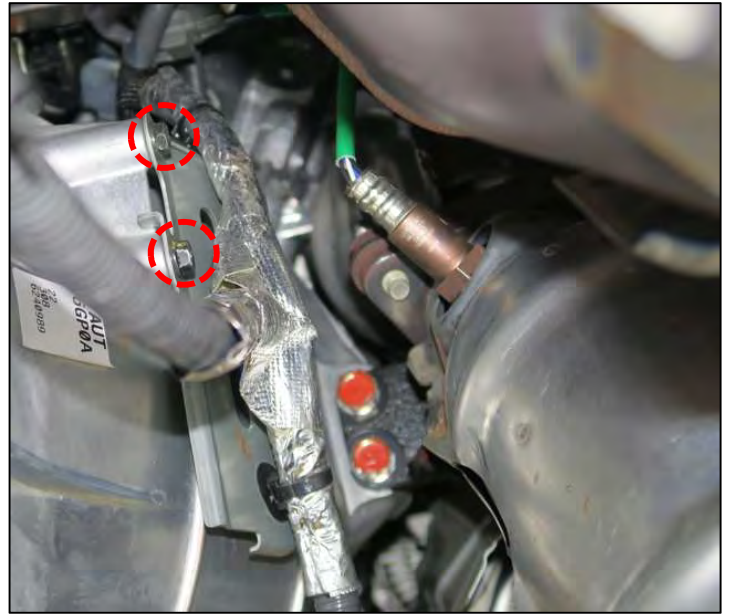

Figure 84

86. Reinstall the rear engine mount (transmission mount) to the transmission. (Figure 85)

- Torque the (2) bolts to 49 N•m(5.0 kg-m, **36 ft-lbs**)

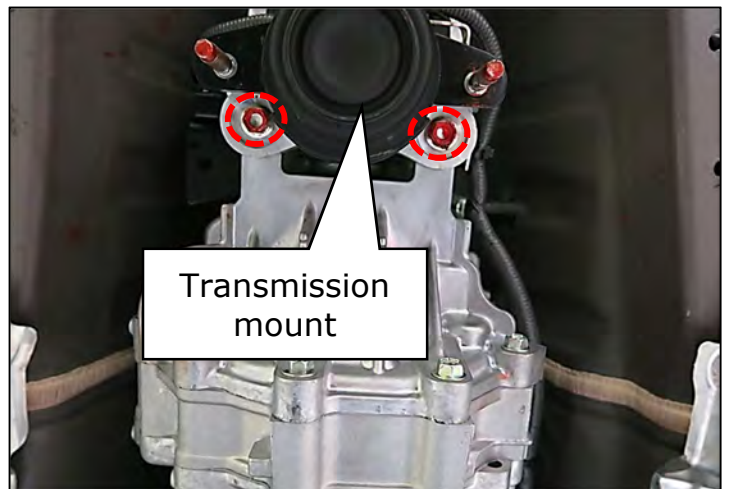

Figure 85

NOTE:

The transmission mount has an arrow that indicates the front of the vehicle to assist with positioning the part. (Figure 86)



Figure 86

87. Install the transmission crossmember to the transmission mount and start the (2) nuts by hand. (Figure 87)

- Using the transmission jack, raise the transmission up until the crossmember makes contact with the vehicle chassis
- Start the (4) crossmember to chassis bolts by hand, then torque the (4) bolts and the (2) nuts to 49 N•m(5.0 kg-m, **36 ft-lbs**)

NOTE:

The transmission cross member has an arrow that indicates the front of the vehicle to assist with positioning the part. (Figure 88)

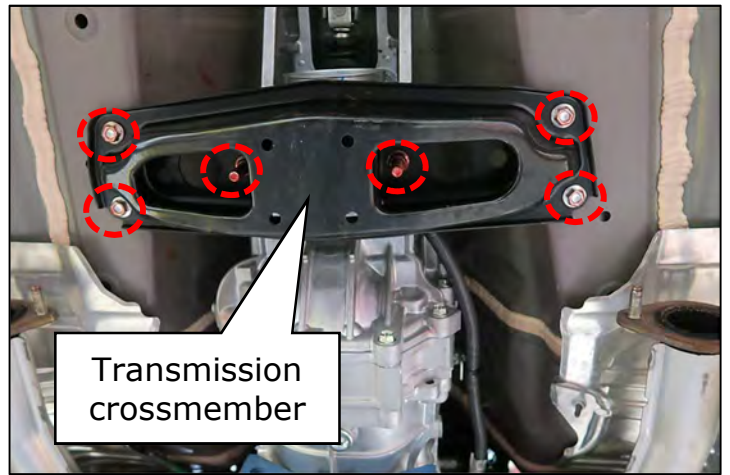

Figure 87



Figure 88

88. Remove the strap securing the transmsision to the transmission jack and lower the jack.

89. Move the wire harness into position shown in Figure 89.

- Start the bolts for the (2) lower wire harness retainer brackets by hand
- Torque the (2) bolts to 28 N•m(2.9 kg-m, **21 ft-lbs**)

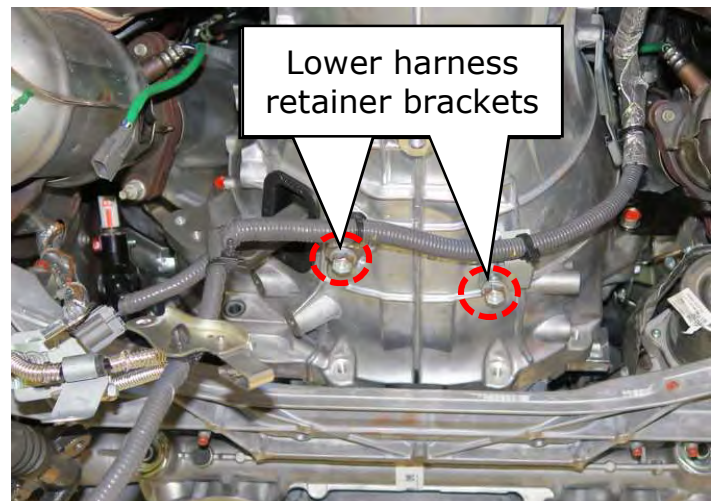

Figure 89

90. Move the starter motor into position in the transmission housing, making sure to align the starter motor dowls with the bolt holes in the transmission case. (Figure 90)

- Install the upper starter motor bolt through the starter harness retainer
- Start the lower starter motor bolt by hand
- Torque the (2) starter motor bolts to 48 N•m(4.9 kg-m, **35 ft-lbs**)

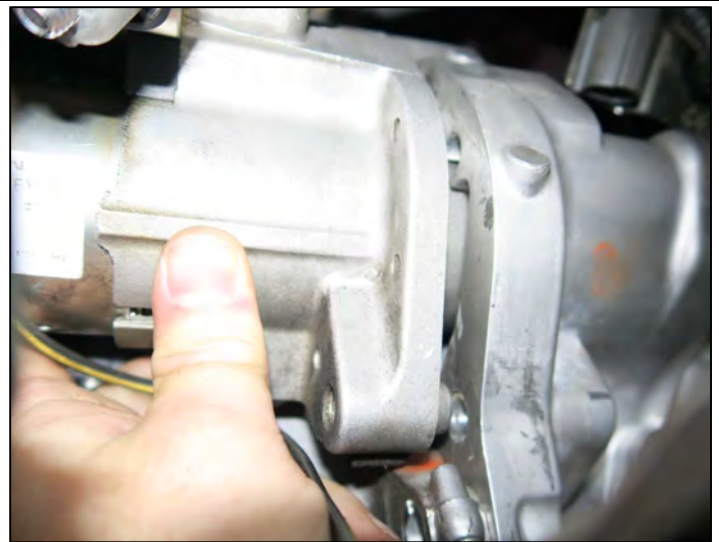

Figure 90

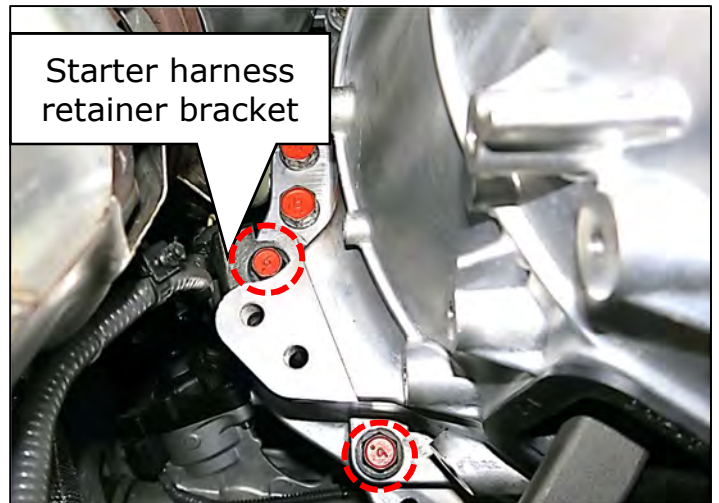

Figure 91

91. Connect the starter harness connector. (Figure 92)

NOTE:

An audible click will be heard once the connector is fully seated.

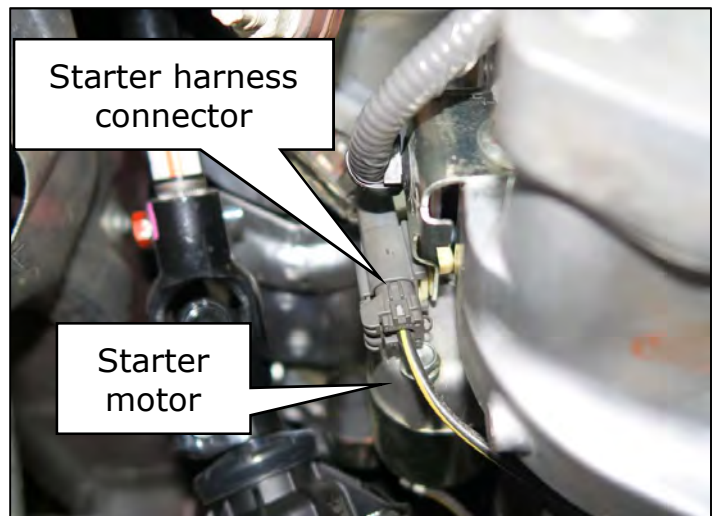

Figure 92

92. Route the wiring harness as shown in Figure 93.

- Start the bolts for the 2 harness retainer brackets shown in Figure 93
- Insert the 2 harness retainers into the transmission case holes
- Torque the 2 harness retainer bolts to 7 N•m(0.71 kg-m, **62 in-lbs**)

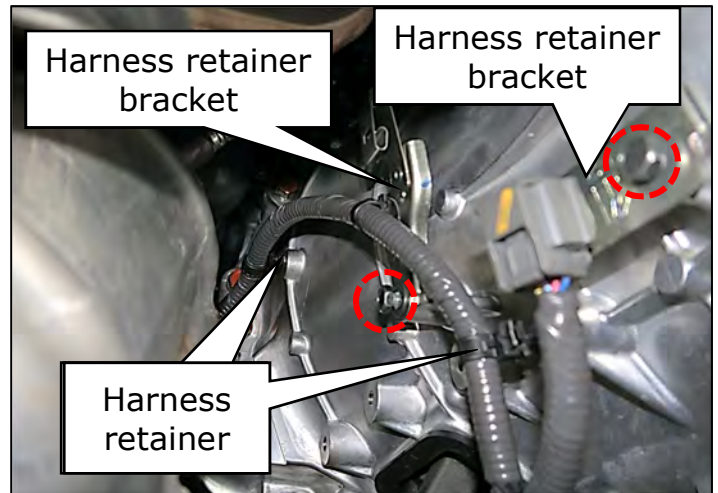

Figure 93

93. Connect the LH rear O2 sensor connector. (Figure 94)

- Route the rear O2 sensor harness into the retainer bracket

NOTE:

An audible click will be heard once the connector is fully seated.

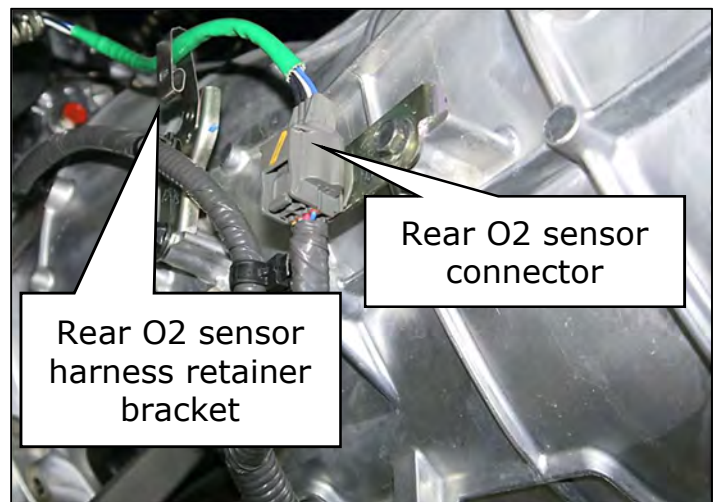

Figure 94

94. Install the LH catalytic converter support bracket. (Figure 95)

- Install and torque the 3 bolts to 47.8 N•m(4.9 kg-m, **35 ft-lbs**)

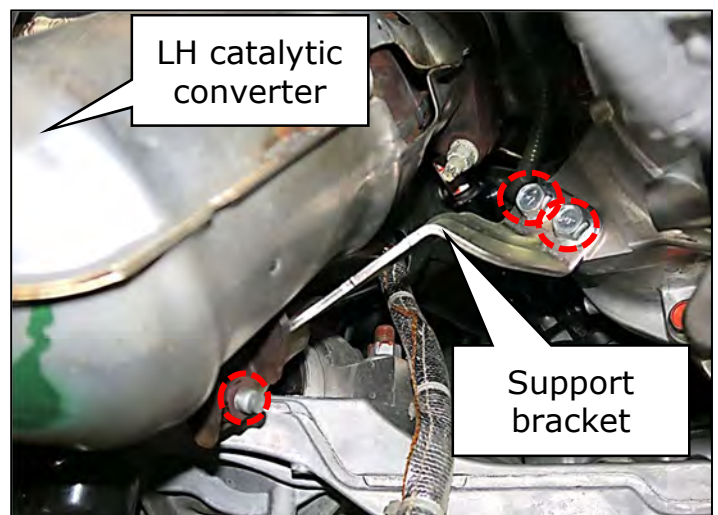

Figure 95

95. Install the clutch release cylinder. (Figure 96)

- Align the clutch operating cylinder rod with the clutch release fork
- Carefully push the rod toward the rear of the vehicle until the holes in the release cylinder align with the transmission case holes
- Install the bolts by hand and torque to 23.4 N•m(2.4 kg-m, **17 ft-lbs**)

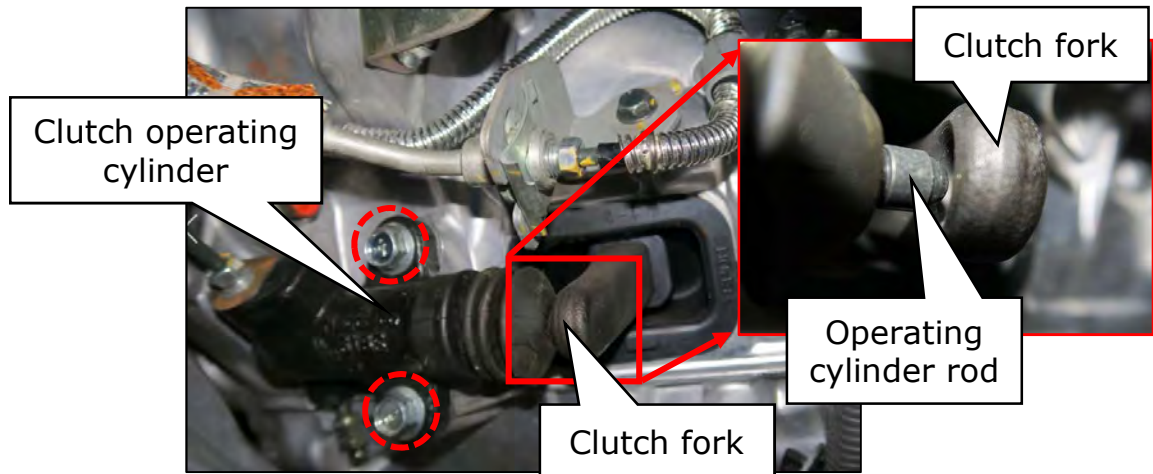

Figure 96

96. Install the (2) hydraulic clutch line bracket bolts. (Figure 97)

- Torque bolts to 7 N•m(0.71 kg-m, **62 in-lbs**)

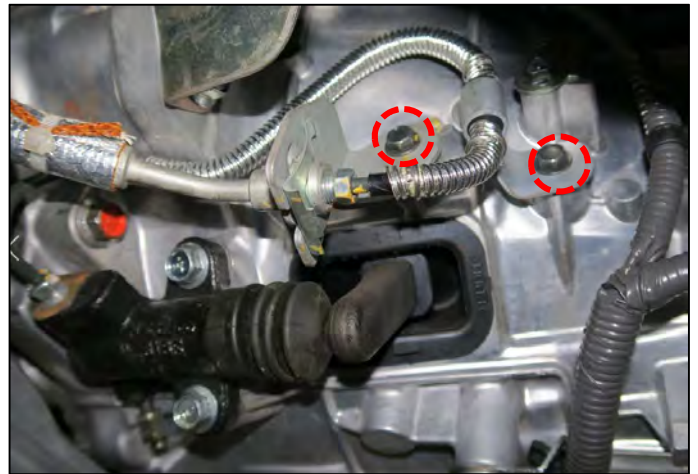

Figure 97

97. Reinstall the front suspension member stay.

- Install the (6) nuts and washers and the (2) bolts. (Figure 98)
- Torque the bolts and nuts to 40 N•m(4.1 kg-m, **30 ft-lbs**)

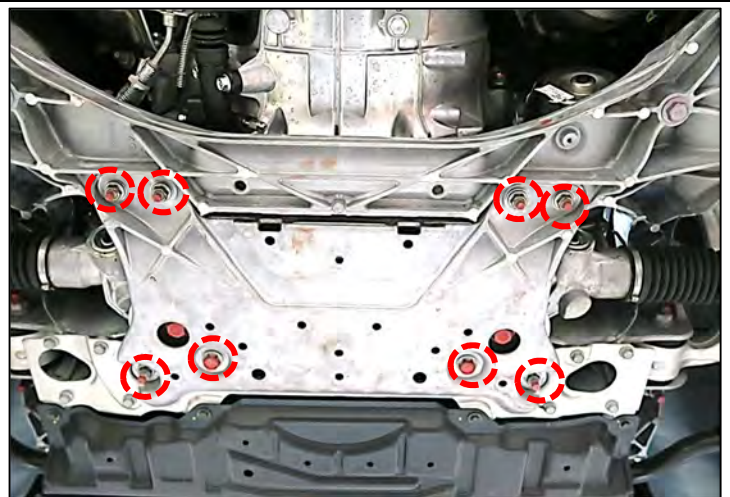

Figure 98

98. Lower the vehicle down.

99. Install the shifter assembly.

- Insert the shifter spring into the transmission bracket
- Align the shifter as shown in Figure 99 with the lower bushing hole facing the vehicle doors
- Align the locating tab on white plastic collar with the slot on the transmission (Figure 100)
- Push the shifter down until the shifter guide plate is flush with the transmission bracket (Figure 101)
- Start the (3) bolts by hand
- Torque the bolts the bolts to 9.6 N•m(0.98 kg-m, **85 in-lbs**)

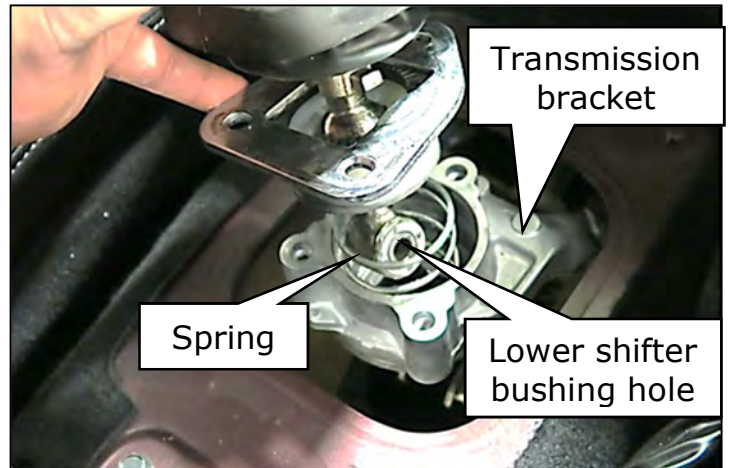

Figure 99

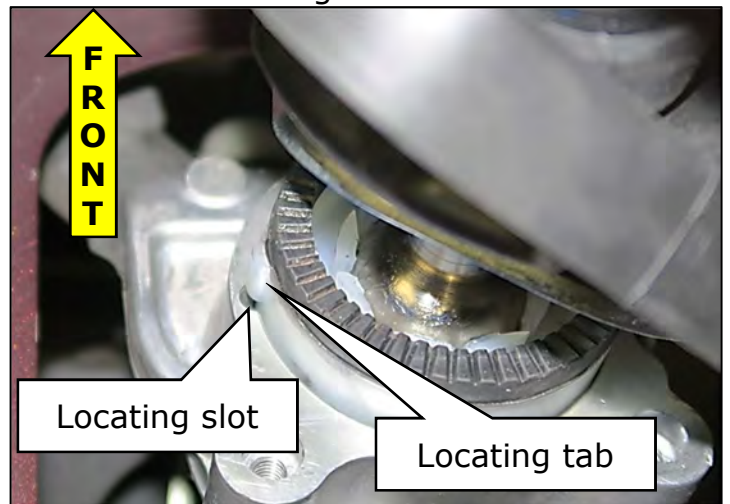

Figure 100

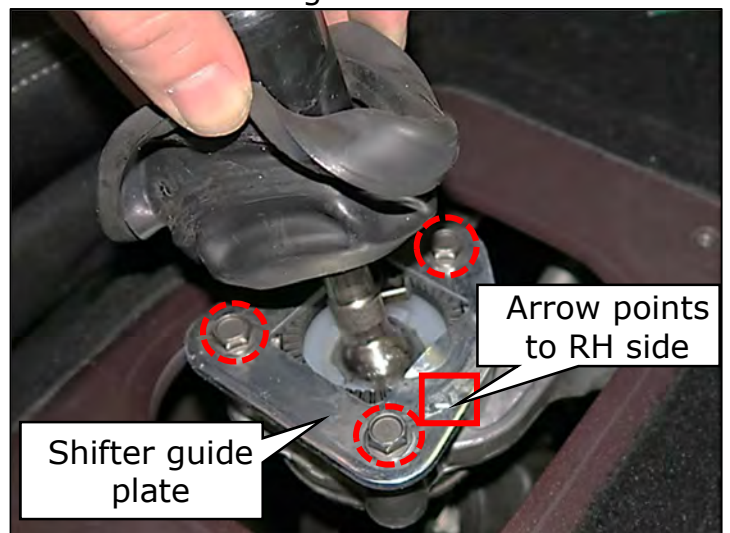

Figure 101

100. Install the guide plate boot over the shifter guide plate. (Figure 102)

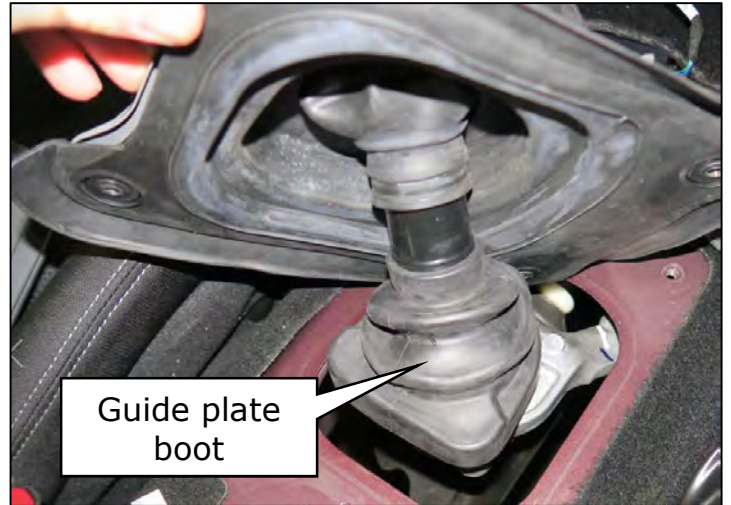

Figure 102

101. Reinstall the hole cover.

- Tuck the edges of the rubber boot under the carpet on the top and both sides (Figure 103)
- Install the (4) bolts and start by hand
- Torque the bolts to 5.5 N•m(0.56 kg-m, **49 in-lbs**)

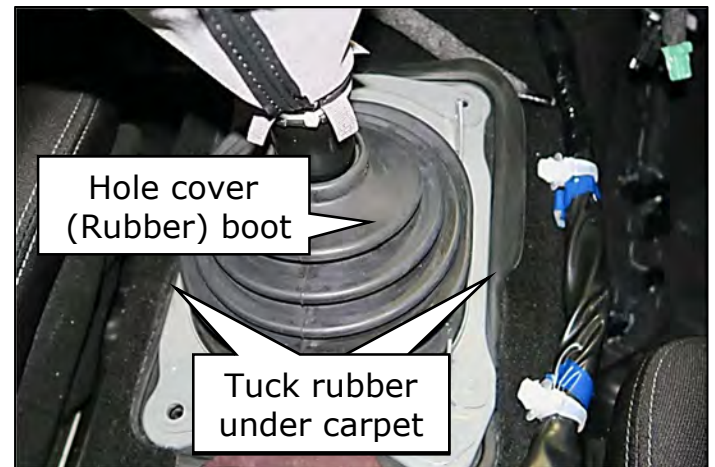

Figure 103

102. Install the harness retainers to the hole cover. (Figure 104)

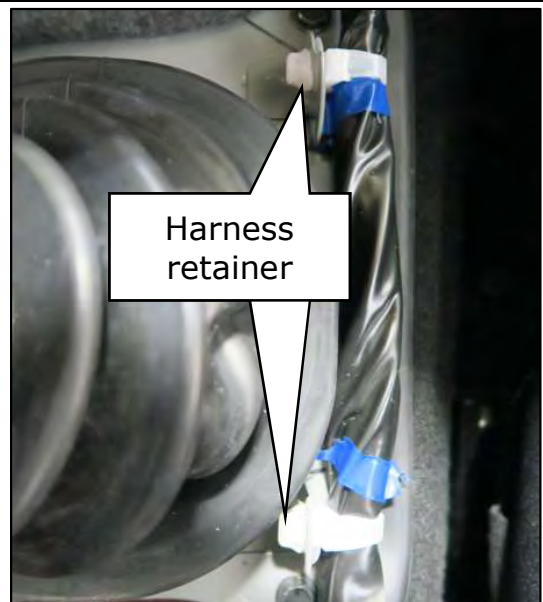

Figure 104

103. Orient the shifter so that the text on the shifter knob can be read as shown in Figure 105.



Figure 105

104. Carefully install the center console assembly.

- Route the console rear first through the RH door and toward the rear of the vehicle (Figure 106)
- Align the front of the center console with the instrument panel
- Align the parking brake handle with the slot in the center console



Figure 106

NOTICE: Be careful to not scratch the interior components during reinstallation.

105. Position the center console side alignment tabs with the instrument panel side trim on the LH and RH sides of the center console. (Figure 107)

- Slide the center console forward
- Align the console alignment tabs with the console alignment holes (just below mounting screw holes) (Figure 108)
- Install the (2) front console screws (Figure 108)
- Lower the front of the console down

NOTICE: Be careful to not scratch the interior components during reinstallation.

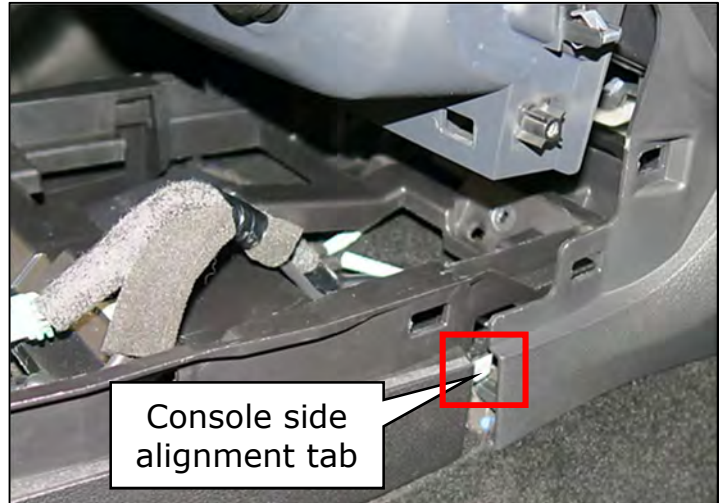

Figure 107

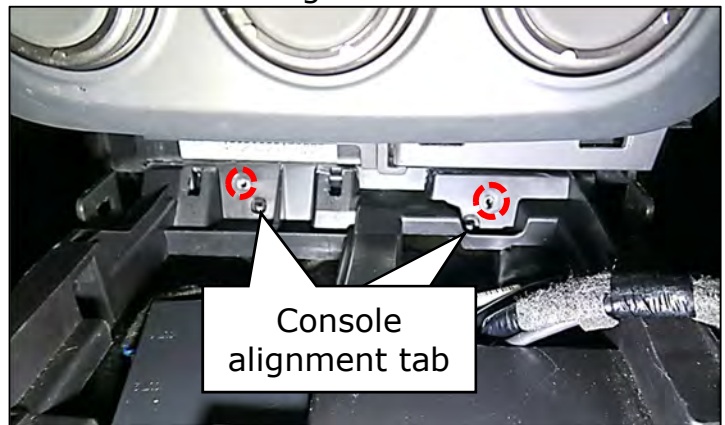

Figure 108

106. Move the wiring harness connectors upward through the openings in the center console as shown in Figure 109 and Figure 110.

- Lower the console all the way down.

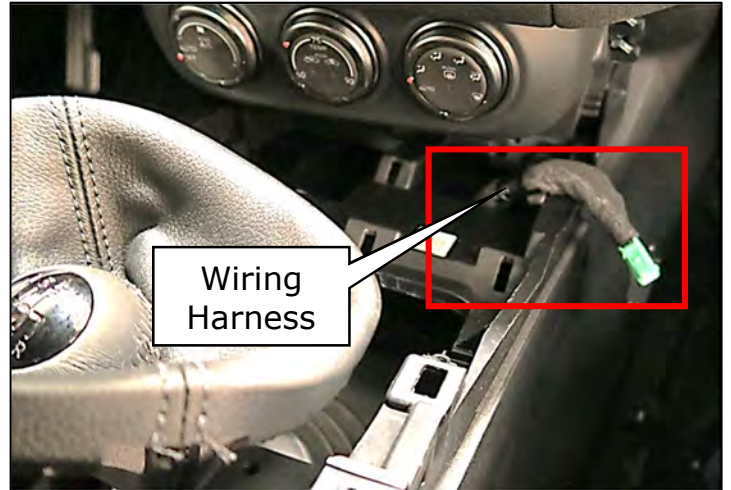

Figure 109

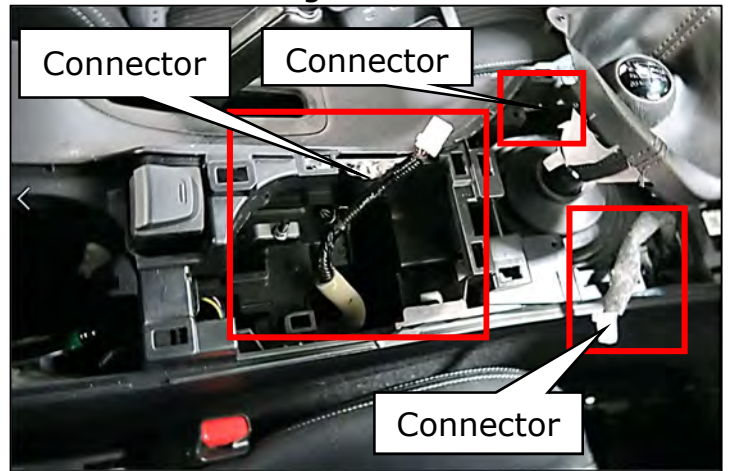

Figure 110

107. Install the USB port finisher.

- Connect the (2) harness connectors to the USB ports
- Place the USB finisher in the position shown in Figure 111, but do **NOT** seat the retaining clips at this time

NOTE:

An audible click will be heard once the connector is fully seated.



Figure 111

108. Install the Console tray finisher.

- Carefully install the tray finisher under the USB finisher (Figure 112)
- Starting with the rear of the console tray finisher, seat the retainer clips by pushing downward (Figure 113)
- Align the the USB finisher assembly retaining clips and push toward the front of the vehicle to seat the retainer clips

NOTICE: Be careful to not scratch the interior components during reinstallation.



Figure 112



Figure 113

109. Install the USB finisher screw.
(Figure 114)

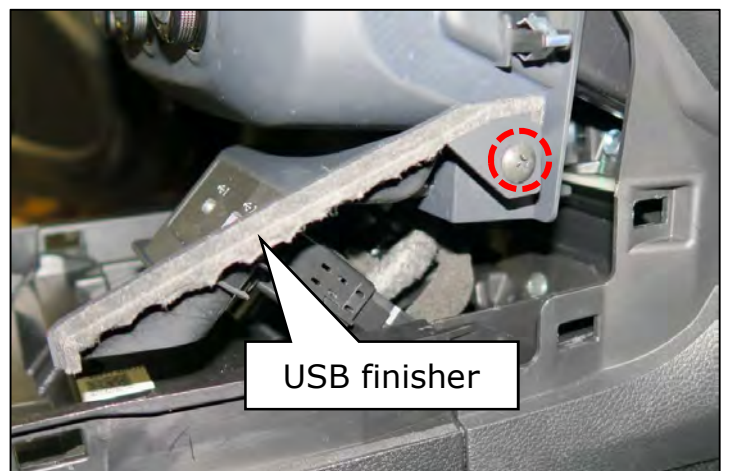

Figure 114

110. Install both LH and RH console side finishers. (Figure 115)



Figure 115

111. Install the (2) screws that secure the console side finishers. (Figure 116)



Figure 116

112. Place the shifter finisher over the shifter assembly as shown in Figure 117.



Figure 117

113. Place the shifter trim ring over the shifter assembly. (Figure 118)

- Locate the front of the trim ring by placing it into the shifter finisher and checking fitment
- If the trim ring does not fit, rotate the trim ring 180° and verify trim ring fitment

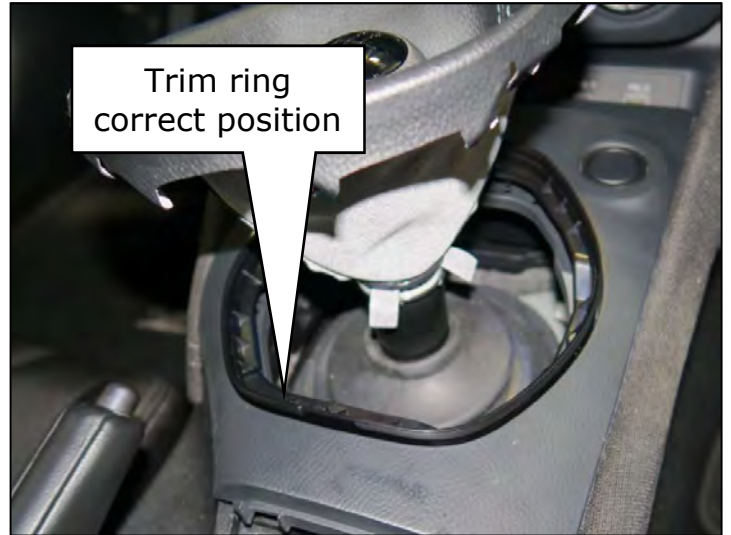

Figure 118

114. Lift the trim ring up and align the front center of the shift boot stitching with the front center of the trim ring. (Figure 119)

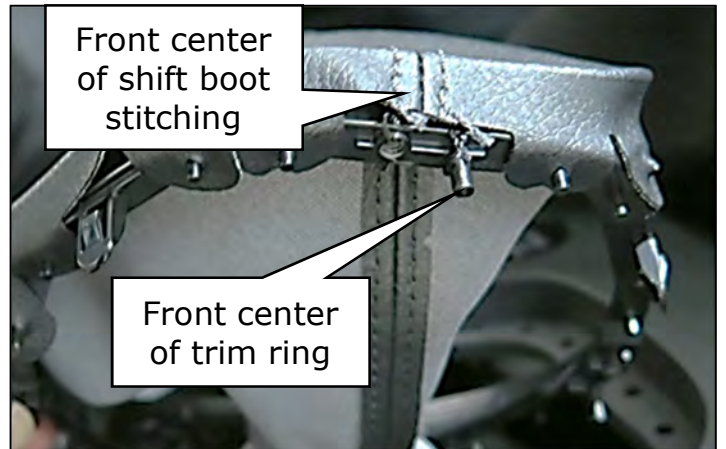

Figure 119

115. Carefully install the shift boot over the trim ring. (Figure 120)

- Align the shift boot holes with the trim ring pins as shown in Figure 120

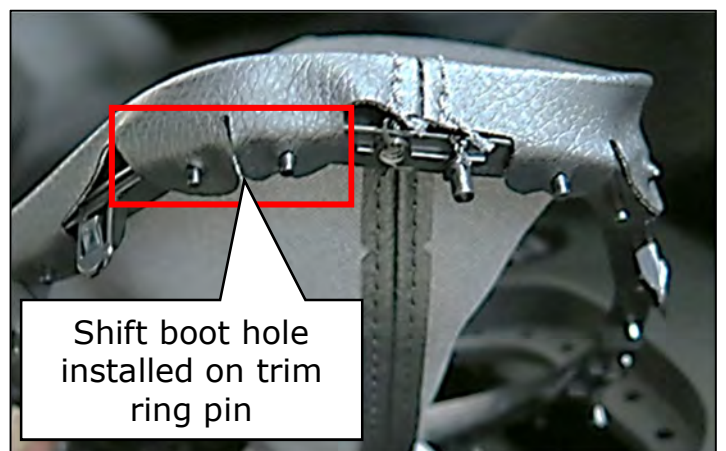

Figure 120

116. Carefully install the trim ring and shift boot into the shifter finisher.
- Position the trim ring/shifter boot over the shifter finisher (Figure 121)
 - Carefully push the trim ring/shifter boot into the shifter finisher
 - Verify the shifter boot is aligned with the stitching centered on the front and the rear of the shifter finisher (Figure 121)

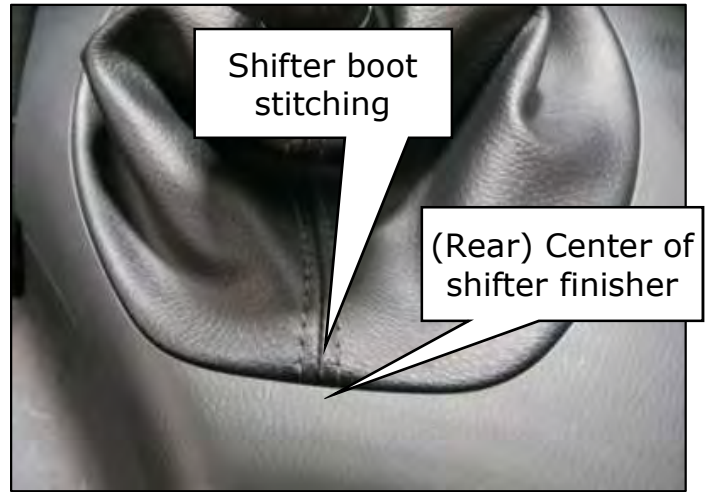

Figure 121

117. Install the (4) screws securing the the trim ring to the shifter finisher.
- Lift the shifter finisher upward and install the (4) screws shown in Figure 122

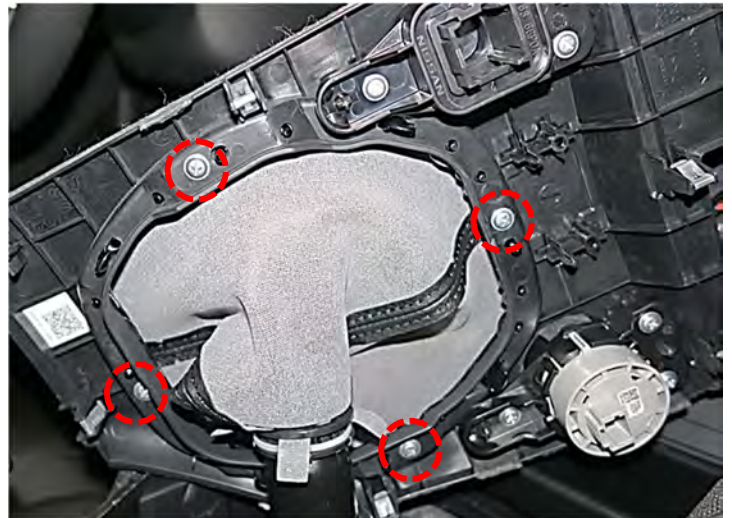

Figure 122

118. Reconnect the ignition button and the drive mode button (if equipped). (Figure 123)

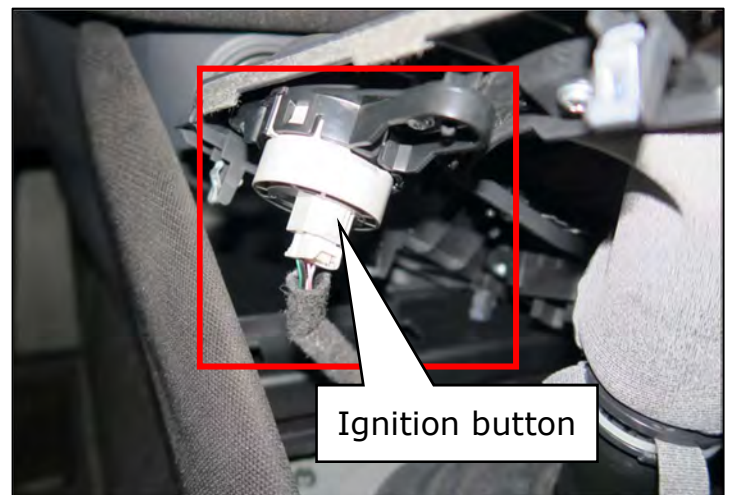

Figure 123

119. Install the shifter finisher.
(Figure 124)

- Align the shifter finisher retaining clips with the center console holes
- Push the shifter finisher downward to seat the finisher
- Reinstall the console tray finisher mat



Figure 124

120. Raise the vehicle on the lift.

121. Connect the transmission control rod to the shifter assembly.
(Figure 125)

- Install the bolt and torque to 14.2 N•m(1.4 kg-m, 10 ft-lb)

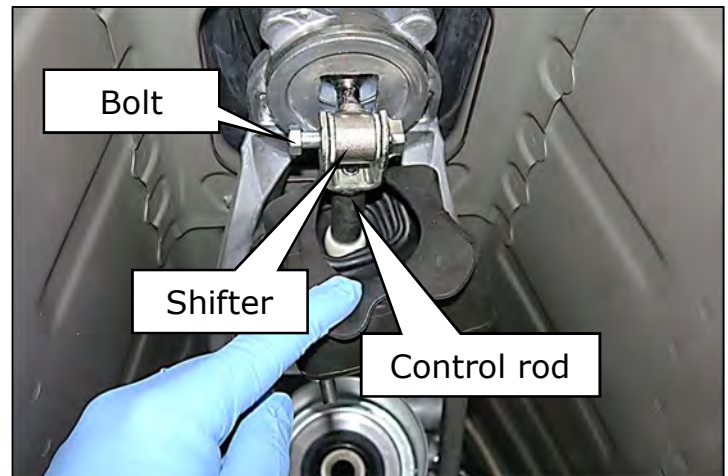

Figure 125

122. Install the transmission control rod boot onto the rear transmission bracket. (Figure 126)

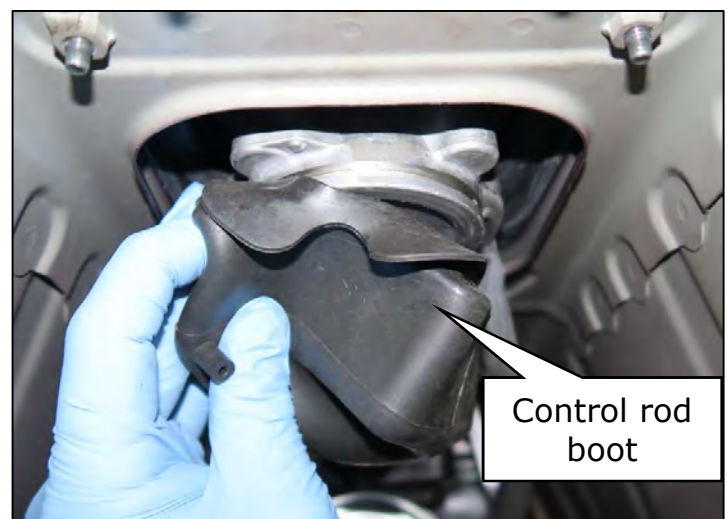

Figure 126

123. Install the rear propeller shaft.
(Figure 127)

- Carefully position the rear propeller shaft in the vehicle
- Align the propeller shaft yoke splines with the splines on the transmission output shaft and slide into the transmission
- Place the propeller shaft onto the rear differential flange and align the marks made in Step 13
- Install the (4) NEW bolts and (4) NEW nuts connecting the propeller shaft to the rear differential
- Torque the fasteners to 74 N•m(7.5 kg-m, **55 ft-lbs**)

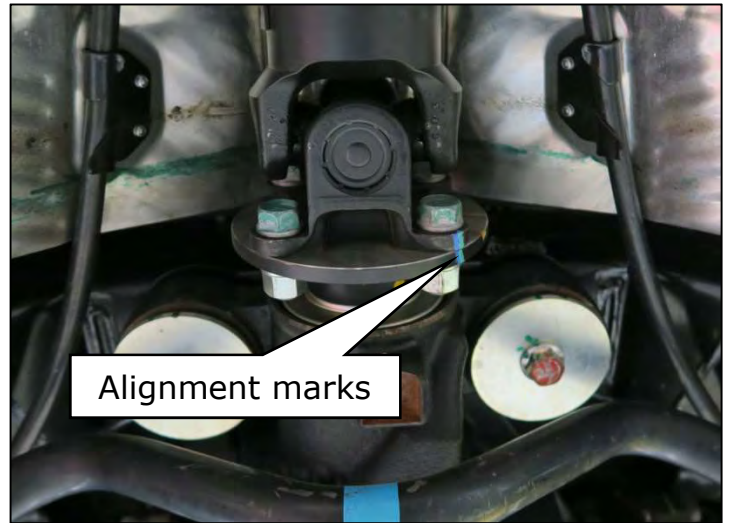

Figure 127

124. Reinstall the exhaust heat shield.

- Pull downward on the rear suspension member and slide the heat shield into position as shown in Figure 128

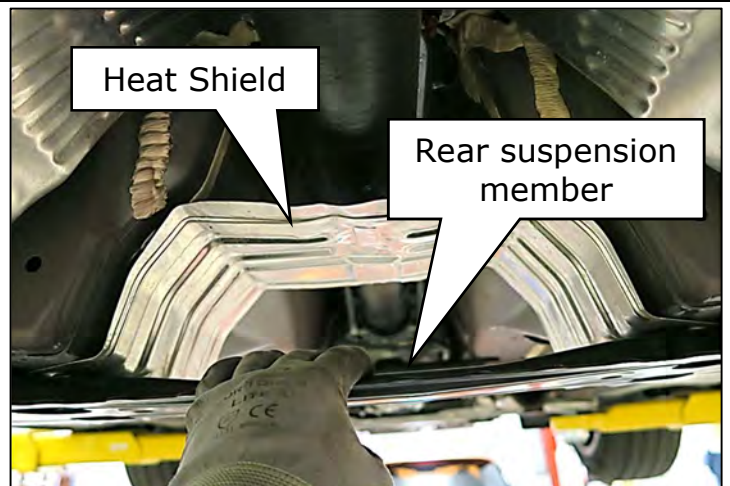

Figure 128

125. Reinstall the (4) rear suspension member bolts and the (2) heat shield bolts. (Figure 129)

- Torque the rear suspension member bolts to 32 N•m(3.3 kg-m, **24 ft-lbs**)
- Torque the heat shield bolts to 7 N•m(0.71 kg-m, **62 in-lbs**)

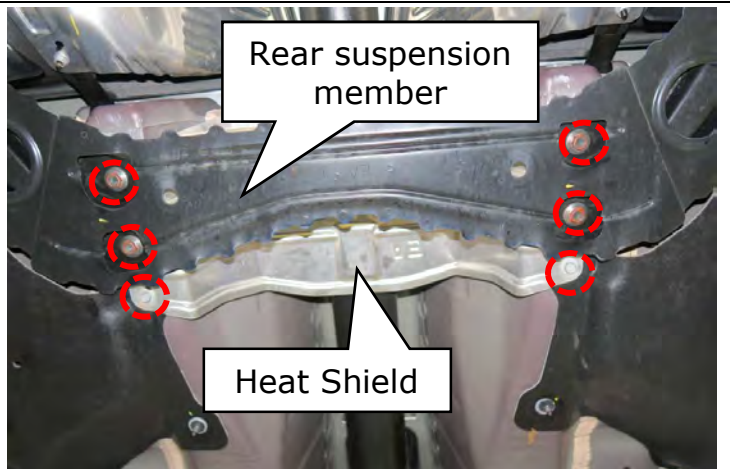

Figure 129

126. Install (2) NEW gaskets onto the catalytic converters and install the front exhaust tube assembly. (Figure 130)

- Start the (4) front exhaust tube to catalytic converter nuts by hand using **NEW** nuts (Figure 131)
- Do not torque the nuts yet



Figure 130

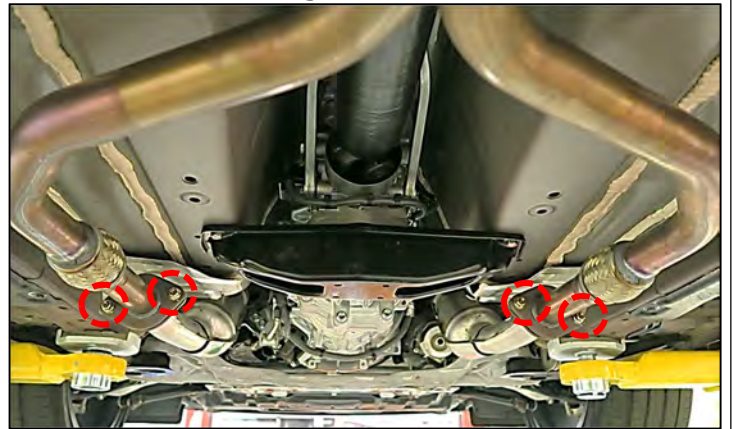

Figure 131

127. Install (2) NEW gaskets onto the rear of the rear exhaust tube. (Figure 132)

- Install (1) NEW gasket on the rear of the Front exhaust tube (Figure 133)

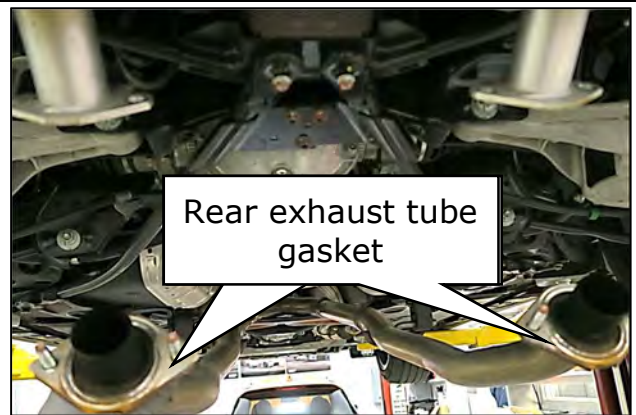

Figure 132



Figure 133

128. Install the rear exhaust tube into the vehicle and connect it to the front exhaust tube and the muffler assembly. (Figure 134)

- Start the nuts by hand.

NOTE:

The original nuts will be reused for:

- Front exhaust tube to rear exhaust tube connections
- Rear exhaust tube to muffler connections

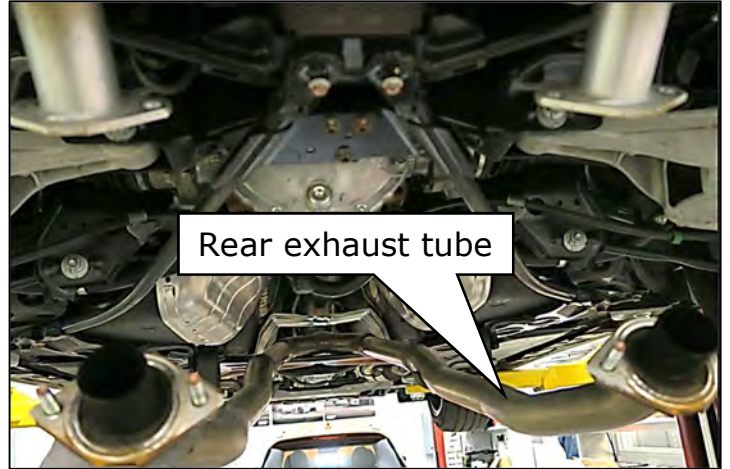

Figure 134

129. Reinstall the rear exhaust tube mounting brackets and hand start the (2) nuts. (Figure 135)

- Torque the nuts to 14.2 N•m (1.4 kg-m, **10 ft-lbs**)



Figure 135

130. Torque the front exhaust tube bolts to 52.5 N•m (5.4 kg-m, **39 ft-lbs**). (Figure 136)

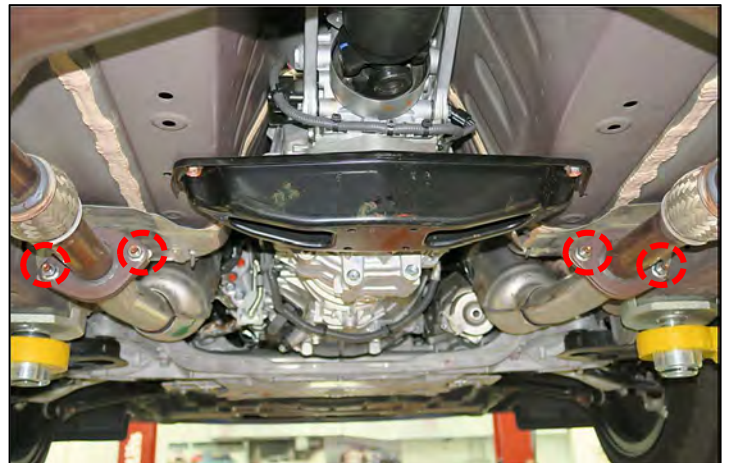

Figure 136

131. Torque the front to rear exhaust tube nuts to 58 N•m(5.9 kg-m, **43 ft-lbs**). (Figure 137)

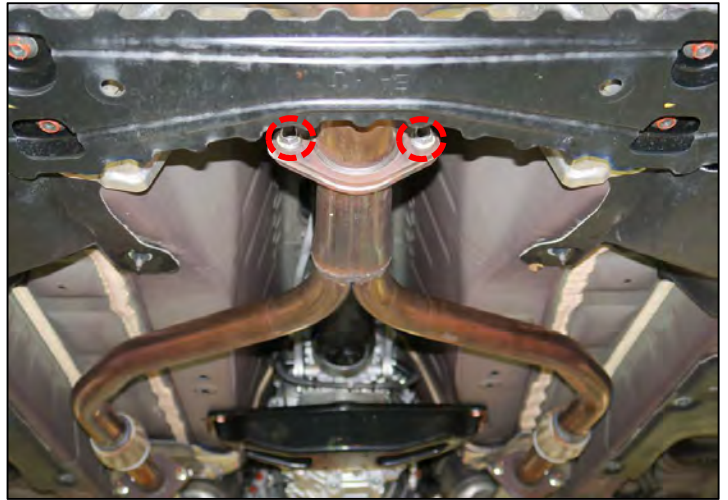

Figure 137

132. Torque the muffler nuts to 58 N•m(5.9 kg-m, **43 ft-lbs**). (Figure 138)



Figure 138

133. Lower the vehicle down until the wheels are 4-6" off the ground.

134. Enter the vehicle and verify the transmission is in the Neutral position.

IMPORTANT: This process should be performed with the rear wheels off the ground.

135. Adjust the parking brake lever.

- a) Lower the parking brake lever half way down
- b) Tighten the parking brake lever adjustment nut several turns Figure 139
- c) Completely lower the parking brake lever
- d) Verify the rear wheels turn freely
 - If the rear wheels are difficult to turn or do not turn, loosen the parking brake lever adjustment nut 1-2 turns while rechecking the rear wheel movement with each adjustment
- e) Slowly pull upward on the parking brake lever while counting the number of notches (clicks)
- f) The total number of clicks with moderate effort should be 6-7 clicks
 - Tighten the parking brake adjustment nut to reduce the number of clicks
 - Loosen the parking brake adjustment nut to raise the number of clicks
- g) Completely lower the parking brake lever and check to make sure the rear wheel spin freely

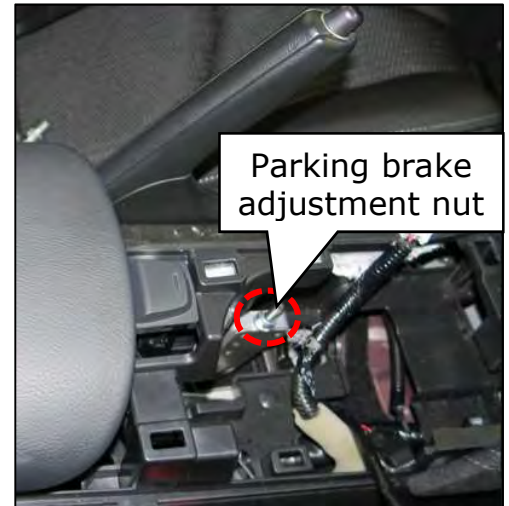

Figure 139

136. Open the center console lid.
(Figure 140)

- Press the console release button and lift the console lid to the open position

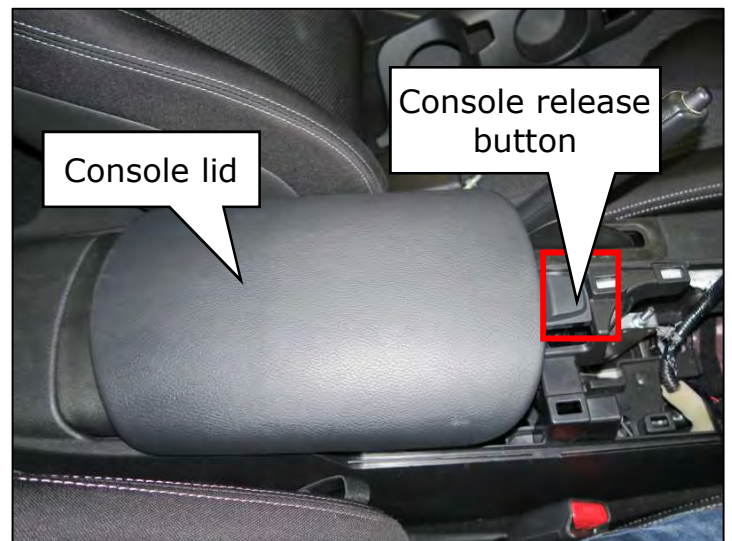

Figure 140

137. Reconnect the center console harness connector. (Figure 141)

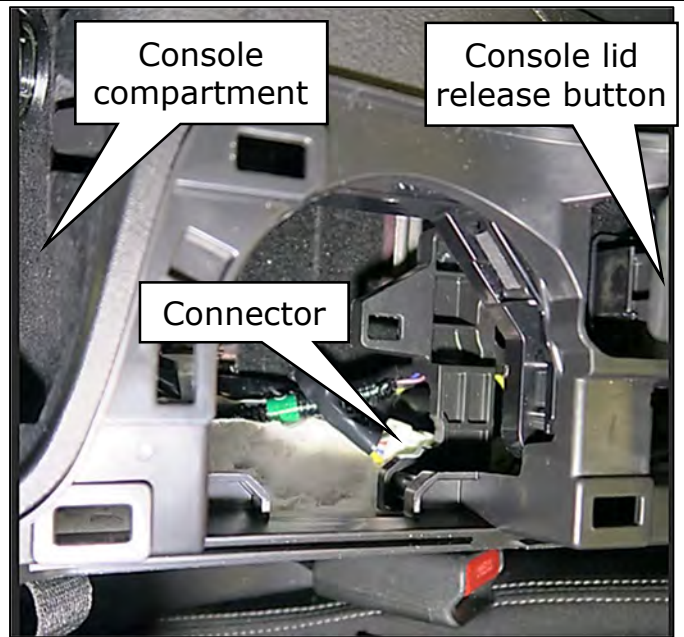

Figure 141

138. Install the cup holder assembly.
- Connect the harness connector(s) for the trunk release and heated seat (if equipped) switches. (Figure 142)
 - Insert the harness retainer into the mounting point located on the cup holder
 - Position the cupholder assembly into the center console
 - Push the cupholder downward to seat the retainers into the center console (Figure 143)

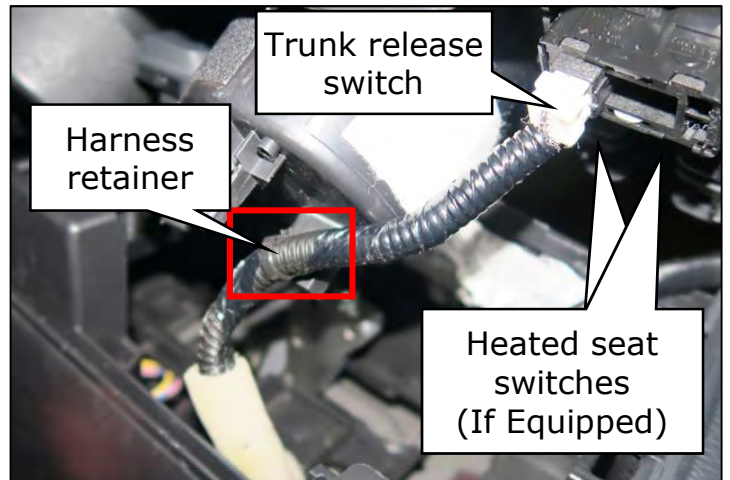

Figure 142



Figure 143

139. Lower the vehicle down.

140. Reconnect the battery and torque the battery terminals to 5.4 N•m(0.55 kg-m, 48 in-lb).

141. Move both seatbacks and seat bottoms fully forward. (Figure 144)



Figure 144

142. Install the (2) rear center console screws. (Figure 145)

- Move both seatbacks to the original position



Figure 145

- For Performance models continue to **Step 143**.
 - Vehicles equipped with the Performance package will have the "S" Mode switch to the right of the shifter assembly.
- For Sport models continue to **Step 159** for Quality checks.

143. Connect CONSULT 3+ (C3+) VI to the data link connector.

- Without depressing the clutch pedal, press the ignition button 2 times to turn the ignition to the ON position

144. Double the click the C3+ icon to open the C3+ program.

145. Enter login credentials and select enter.



Figure 146

146. Select **Diagnosis (All Systems)**.

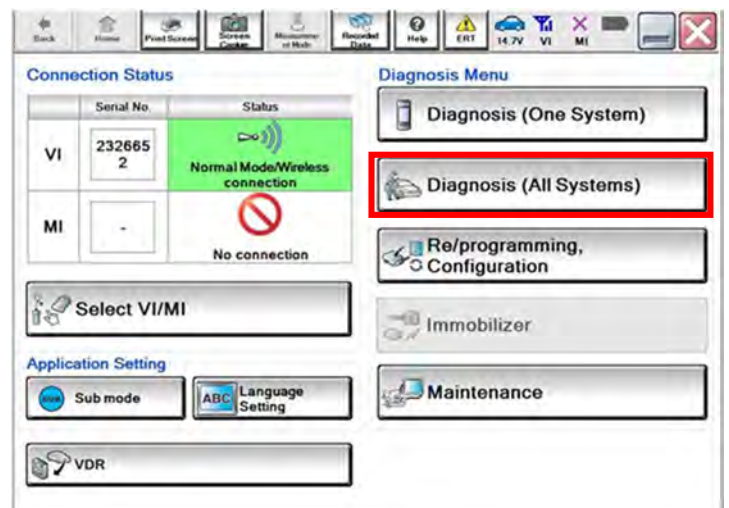

Figure 147

147. Select **Automatic Selection(VIN)**.

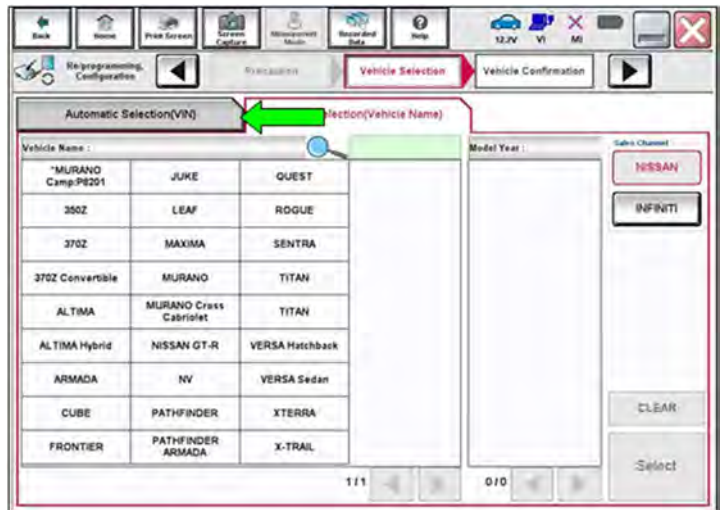

Figure 148

148. Allow C-III plus to perform automatic VIN selection.

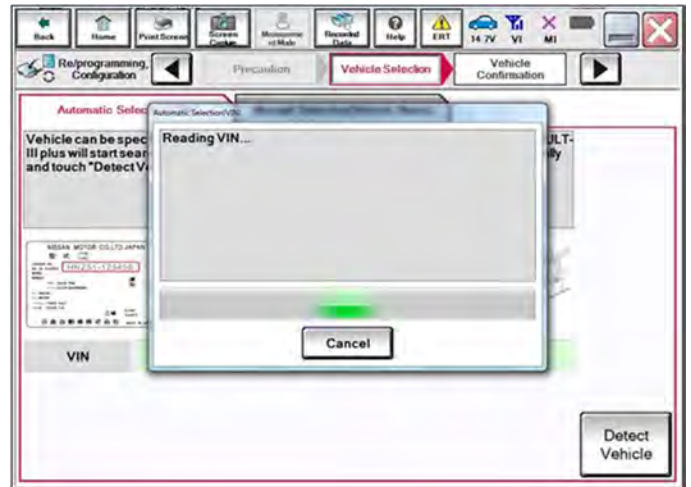

Figure 149

149. Confirm the **VIN or Chassis #** is correct, and then select **Confirm**.

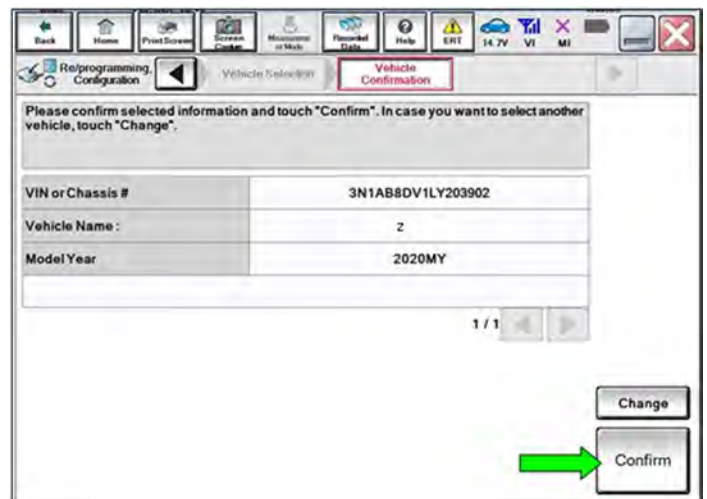

Figure 150

150. Allow the System call to be performed.

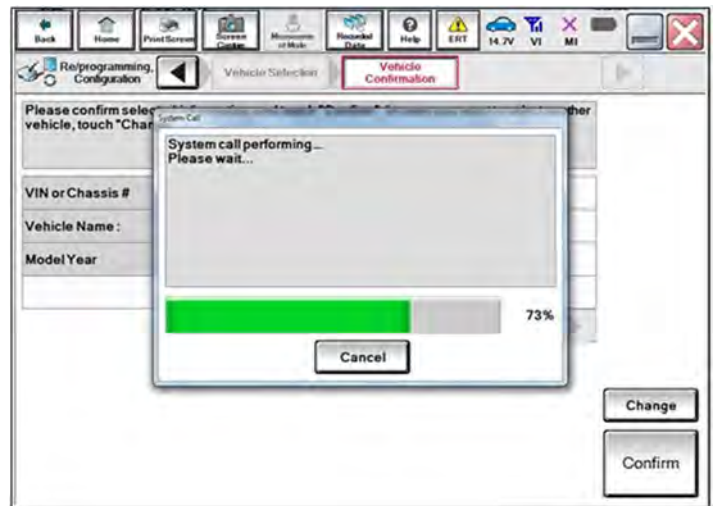

Figure 151

151. Select **ENGINE**. (Figure 152)

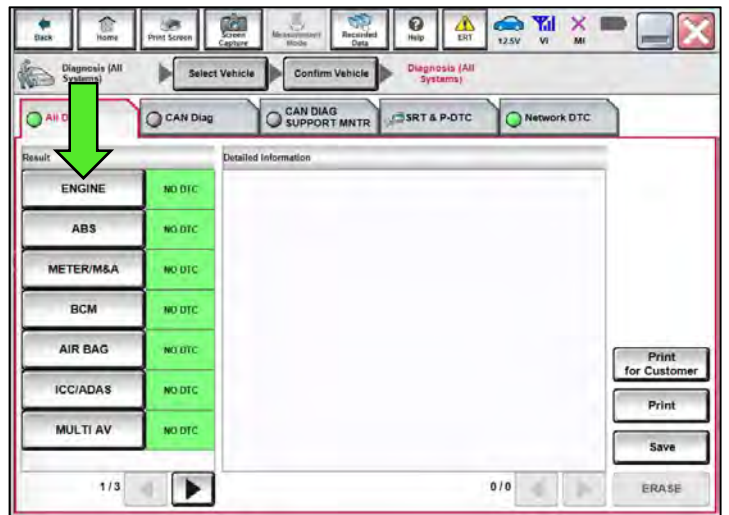

Figure 152

152. Select **Work Support**.

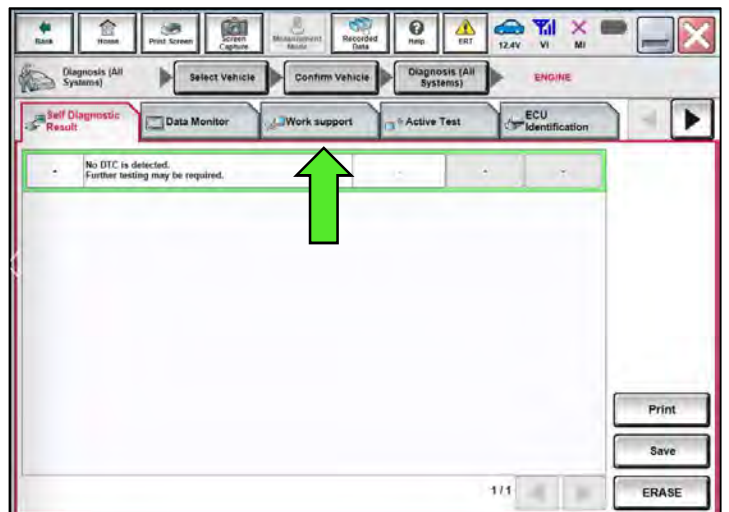

Figure 153

153. Select the forward arrow to move to Page 2.

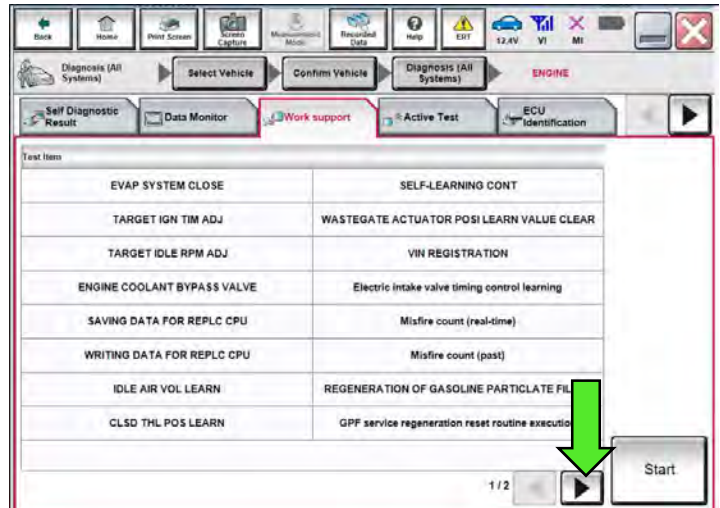

Figure 154

154. Select **M/T NEUTRAL POS LEARN**.

- Select **Start**

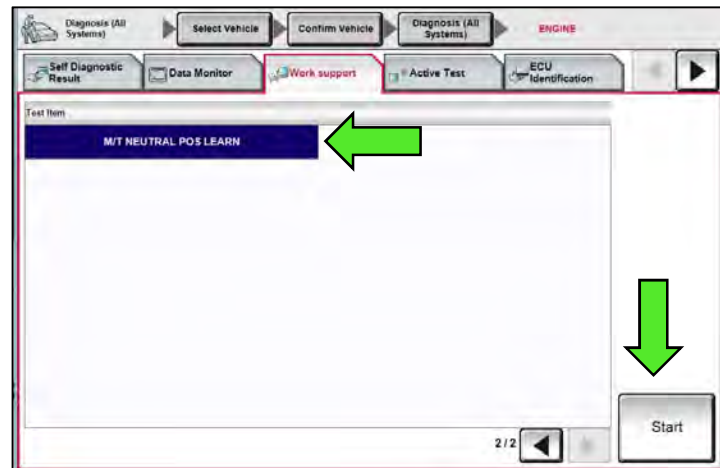

Figure 155

155. Place the vehicle into the below conditions and select **Start**.

- Ignition ON
- Engine OFF
- Transmission in Neutral

NOTE:

Never touch shift lever during learning. Otherwise, learning may not complete normally.

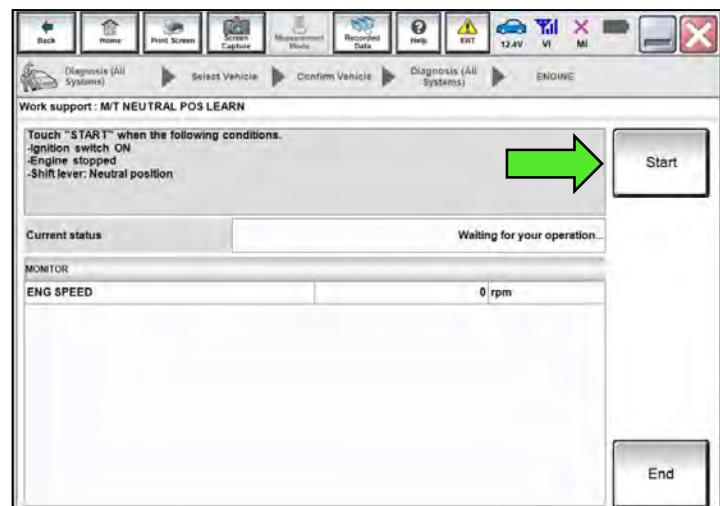

Figure 156

156. Make sure the **COMPLETE** is displayed on CONSULT screen.

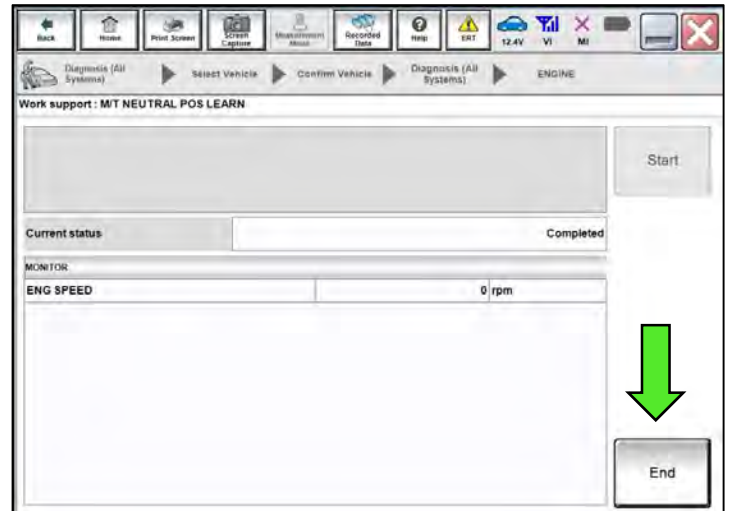

Figure 157

157. Select Diagnosis (All Systems) screen. (Figure 158)

- Verify no DTC's are stored

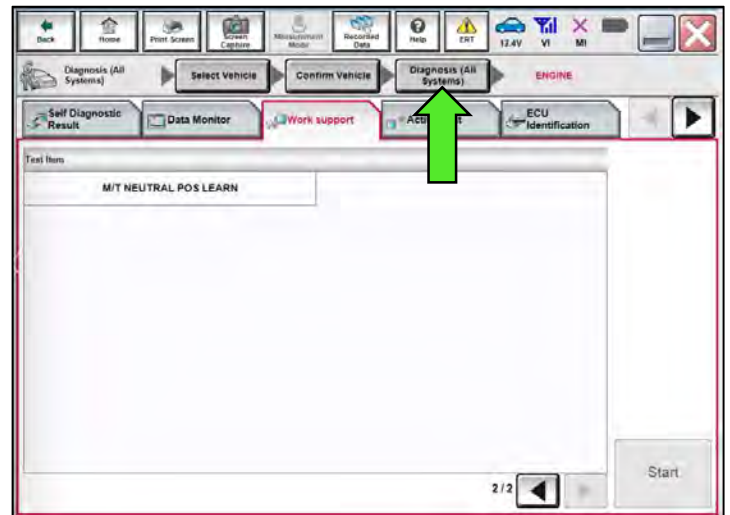

Figure 158

158. Close the C3+ program.

- Turn the ignition off
- Disconnect VI2 from the DLC

159. Perform the below quality checks for the shift control.

- Verify there is no binding or abnormal noise when shifting transmission into each of the gear positions.
- Verify the shift boot is not damaged, twisted, or dislocated.
- Verify the shift knob is straight.

PARTS INFORMATION

Part Number	Description	Qty
320B0-	MANUAL TRANSMISSION	(1)
320B0-	MANUAL TRANSMISSION	(1)
37120-AL60A	BOLT - FIX, PROPELLER SHAFT	4
37171-AL60A	NUT - FIX, PROPELLER SHAFT	4
20692-8H30A	GASKET - EXHAUST	1
20692-JK00B	GASKET - EXHAUST	4
20602-41G0A	NUT - FIX, EXHAUST TUBE	4

(1) Use VIN and EPC to determine correct transmission part number.

CLAIMS INFORMATION

Submit claim using the following claims coding:

Work Order Line Type: "CM" Campaign

CAMPAIGN ("CM") ID	DESCRIPTION	OP CODE	FRT
P2A19	Replace manual transmission with Performance package	P2A190	3.3 hr
	Replace manual transmission	P2A191	3.1 hr