



# Service Bulletin

Bulletin No.: 19-NA-037

Date: February, 2023

## TECHNICAL

**Subject: No Start, Hard Start with Belt Squeal, Belt Break, Loss of Power Steering and/or Power Brake Assist**

Brand:	Model:	Model Year:		VIN:		Engine:	Transmission:
		from	to	from	to		
Chevrolet	Express	2018	2023			4.3L — LV1	All
GMC	Savana	2018	2023			6.6L — L8T	

<b>Involved Region or Country</b>	North America, Middle East and Israel.
<b>Condition</b>	<p>Some customers may comment on one or more of the following:</p> <ul style="list-style-type: none"> <li>• Vehicle will not start.</li> <li>• Vehicle hard to start, with a squeal noise originating from the engine compartment.</li> <li>• Vehicles fan belt broken.</li> <li>• Loss of power steering</li> <li>• Loss of vehicles power brake assist.</li> </ul>
<b>Cause</b>	The cause of the condition may be water leaking from the cowl area into the generator vents. Under certain weather conditions, this water can freeze inside and prevent the generator from turning.
<b>Correction</b>	<ul style="list-style-type: none"> <li>• Replace generator, belt, and any other pulleys that have been contaminated with rubber build up from the belt heating up. Refer to the appropriate repair procedure in SI.</li> </ul> 

5246048

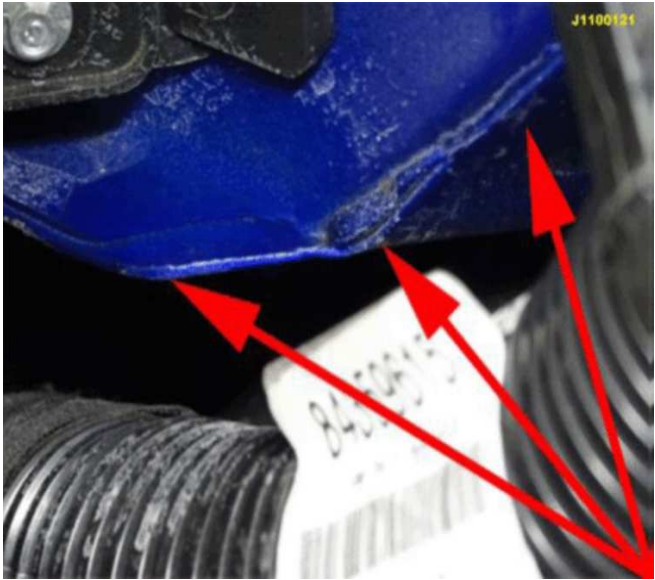
	 <p style="text-align: right; margin-right: 10px;">J1100124</p> <p style="text-align: right; margin-right: 10px;">5246049</p> <p><b>Note:</b> The common location of the water leak path is shown in the graphics above.</p> <ul style="list-style-type: none"> <li>Seal water leak at cowl with Kent Automotive High-Tech™ Clear Seam Sealer, following the steps in the Service Procedure below.</li> </ul>
--	---

**Service Procedure**

**Important:** Service agents must comply with all International, Federal, State, Provincial, and/or Local laws applicable to the activities it performs under this bulletin, including but not limited to handling, deploying, preparing, classifying, packaging, marking, labeling, and shipping dangerous goods. In the event of a conflict between the procedures set forth in this bulletin and the laws that apply to your dealership, you must follow those applicable laws.

1. Remove the air inlet grille panels and the windshield wiper system module (1). Refer to *Windshield Wiper System Module Replacement*, in SI.

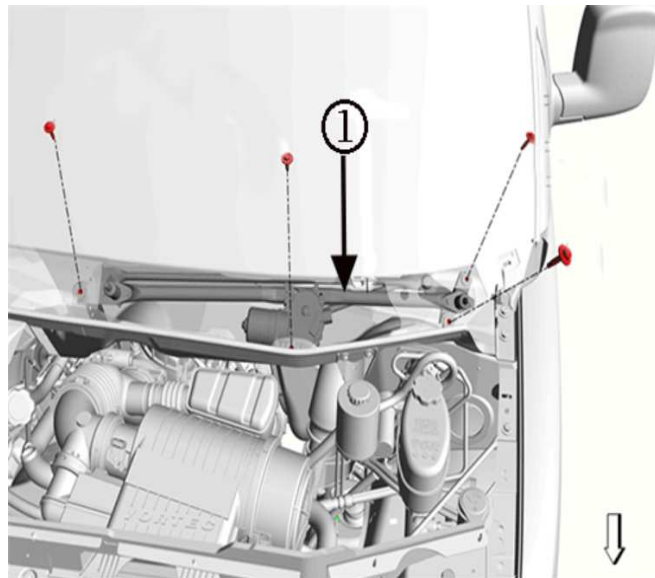

5246053



5246055

2. Note the location of the inner lower right side seam circled in the graphic above.



5246057

**Important:** Be sure to apply the sealer to the entire inner lower right side seam.

3. Apply Kent Automotive High-Tech™ Clear Seam Sealer, # P10200, to the seam.
4. Reinstall the windshield wiper system module (1) and the air inlet grille panels. Refer to *Windshield Wiper System Module Replacement*, in SI.

**Parts Information**

For replacement of generator, belt or pulleys, use the vehicle identification number (VIN), and the GM Electronic Parts Catalogue to determine the proper part to order.

To obtain the High-Tech™ Clear Seam Sealer, contact Kent Automotive at 1-888-YES-KENT (1-888-937-5368).

Causal Part	Description	Part Number	Qty
N/A*	Kent Automotive High-Tech™ Clear Seam Sealer*	P10200 (5 oz)	As needed
* For warranty transactions, DO NOT mark this/these parts as the Causal Part. Enter the word "Bulletin" in the Causal Part Description free-flow text field			

**Warranty Information**

For vehicles repaired under the Bumper-to-Bumper coverage (Canada Base Warranty coverage), use the following labor operation. Reference the Applicable Warranties section of Investigate Vehicle History (IVH) for coverage information.

Labor Operation	Description	Labor Time
1481178*	Wiper System Module R & R and Cowl Reseal	0.8 hr
* This is a unique Labor Operation for Bulletin use only. For consequential damage, use the labor operation associated with this bulletin. All parts and labor associated should be claimed on the same transaction, using OLH as necessary to cover the labor for repair/replacement of the subsequently damaged part(s). Refer to bulletin 18-NA-146 for additional information.		

<b>Version</b>	4
<b>Modified</b>	Released February 26, 2019 Revised January 27, 2020 – Added 2020 Model Year. Revised January 26, 2021 — Added 2021 Model Year and Plant Information. Revised January 26, 2023 — Added the 2022 and 2023 Model Years, removed some part #'s and updated Labor Op#.

