

Service Update

N222388520 Starter Bolts Not Properly Torqued



Release Date: January 2023

Revision: 00

Attention: This service update includes vehicles in dealer inventory and customer vehicles that return to the dealership for any reason. This bulletin will expire at the end of the involved vehicle's New Vehicle Limited Warranty period.

Make	Model	Model Year		RPO	Description
		From	To		
Chevrolet	Express	2022	2023	LV1	ENGINE-GAS, 6 CYL, 4.3L, GEN 5, SIDI, V6, VVT, OHV, ALUM
GMC	Savana			L8T	ENGINE-GAS, 8 CYL, 6.6L, SIDI, VVT, CAST IRON

Involved vehicles are marked "Open" on the Investigate Vehicle History screen in GM Global Warranty Management system. This site should always be checked to confirm vehicle involvement prior to beginning any required inspections and/or repairs.

Condition	Certain 2022-2023 Chevrolet Express and GMC Savana vehicles may have a condition where the starter inner bolt may not be fully torqued.
Correction	Dealers will inspect and retighten the bolts.

Parts

No parts are required for this repair.

Warranty Information

Labor Operation	Description	Labor Time	Trans. Type	Net Item
9106599	Retorque Starter Bolts	0.3	ZFAT	N/A

Service Procedure

1. Lift the vehicle. Refer to *Lifting and Jacking the Vehicle* in SI.

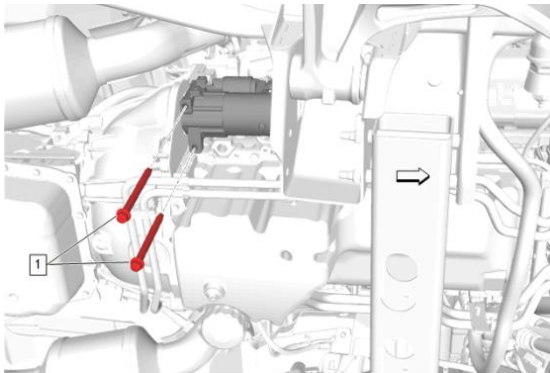

5661979

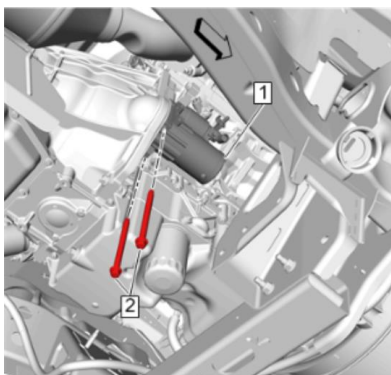

4843873

Service Update

N222388520 Starter Bolts Not Properly Torqued



2. Locate the starter bolts (Noted as (1) above in the L8T graphic, and (2) in the LV3 graphic) and torque them to 50 N-m (37 lb ft).
3. Lower the vehicle. Refer to *Lifting and Jacking the Vehicle* in SI.

Dealer Responsibility

Whenever a vehicle subject to this service update enters your vehicle inventory or is in your facility for service in the future, and the vehicle is still covered under the New Vehicle Limited Warranty, you must take the steps necessary to be sure the service update correction has been made before selling or releasing the vehicle.

All new, used, GM Certified Used, courtesy transportation vehicles, dealer shuttle vehicles, etc. in dealers' possession and subject to this bulletin must be held and inspected/repaired per the service procedure of this bulletin before customers take possession of these vehicles. Involved vehicles must be held and not delivered to customers, dealer-traded, released to auction, used for demonstration, or any other purpose.

All GM Certified Used vehicles currently in the dealers' inventory within the Certified Pre-Owned Inventory System (CPOIS) will be de-certified and must be held and remedied per the service procedure in this bulletin. Upon submitting an accepted/paid warranty transaction in the Global Warranty Management (GWM) system, the vehicle can be re-certified for sale within the CPOIS system, or once again be used in the CTP program.

Dealer Reports – For USA & Export

The Inventory tab of the Open Vehicle Report will contain Service Update Bulletin VINs that apply to this field action. This information is intended to assist dealers with the **PROMPT COMPLETION** of these vehicles. The Customer In-Service tab will not contain Service Update Bulletin VIN data because the intent of a Service Update Bulletin is to not inconvenience a customer with a special trip for service. Service Update Bulletins are to be completed when the customer is in for a regularly scheduled visit.

GM bulletins are intended for use by professional technicians, NOT a "do-it-yourselfer". They are written to inform these technicians of conditions that may occur on some vehicles, or to provide information that could assist in the proper service of a vehicle. Properly trained technicians have the tools, equipment, safety instructions, and know-how to do a job properly and safely. If a condition is described, **DO NOT** assume that the bulletin applies to your vehicle, or that your vehicle will have that condition. See your dealer for information on whether your vehicle may benefit from the information.



**We Support
Voluntary Technician
Certification**

GLOBAL SAFETY FIELD INVESTIGATIONS
DCS6423
URGENT - DISTRIBUTE IMMEDIATELY

Date: January 26, 2023

Subject: N222388520 - Service Update
Starter Bolts Not Properly Torqued

Models: 2022-2023 Chevrolet Express
2022-2023 GMC Savana
Equipped with 4.3L or 6.6L Gas Engine (RPO LV1, L8T)

To: All General Motors Dealers

General Motors is releasing Service Update N222388520 today. The total number of U.S. vehicles involved is approximately 553. Please see the attached bulletin for details.

Global Warranty Management (GWM)

The Required Field Action section on the Investigate Vehicle History (IVH) screen will be updated January 26, 2023. A list of vehicles in dealer inventory is attached to this message. Please hold all warranty transactions until IVH has been updated.

END OF MESSAGE

GLOBAL SAFETY FIELD INVESTIGATIONS