

**January 6, 2023**

Version 1

## Warranty Extension: Engine Does Not Auto Restart After Entering Auto Idle Stop

### AFFECTED VEHICLES

Year	Model	Trim	VIN Range
2021–22	Passport (with 9AT)	ALL (with Idle Stop)	Check the iN VIN status for eligibility.
2021–22	Pilot (with 9AT)	ALL (with Idle Stop)	Check the iN VIN status for eligibility.
2021–23	Ridgeline (with 9AT)	ALL (with Idle Stop)	Check the iN VIN status for eligibility.

### BACKGROUND

Under certain circumstances, after coming to a stop and engaging idle stop, the vehicle may not restart automatically due to excessive cylinder pressure and/or low cranking torque. Typically, the customer can immediately restart the vehicle by selecting Park and pressing the ENGINE START/STOP button.

NOTE: If 23-008 Product Update: PGM-FI Idle Stop Software Update is applicable to the VIN, the PGM-FI software must be updated first before the warranty extension applies.

Honda is extending the warranty coverage for valve adjustment to 10 years from the original date of purchase with no mileage limitation.

### CUSTOMER NOTIFICATION

Owners of affected vehicles will be sent a notification of this campaign.

Do an iN VIN status inquiry to verify eligibility.

### CORRECTIVE ACTION

Adjust the valves.

**CUSTOMER INFORMATION:** The information in this bulletin is intended for use only by skilled technicians who have the proper tools, equipment, and training to correctly and safely maintain your vehicle. These procedures should not be attempted by "do-it-yourselfers," and you should not assume this bulletin applies to your vehicle, or that your vehicle has the condition described. To determine whether this information applies, contact an authorized Honda automobile dealer.

## PARTS INFORMATION

Part Name	Part Number	Quantity
Intake Manifold Gasket	17101-RLV-A01	6
Throttle Body Gasket	17102-RLV-A01	1
EGR Seal	17103-RLV-A01	2
EGR Pipe Gasket A	18716-RB0-G01	1

## REQUIRED MATERIALS

Part Name	Part Number	Quantity
Hondabond (one tube repairs 4 vehicles)	08718-0004	1

## WARRANTY CLAIM INFORMATION

### Passport:

Operation Number	Description	Flat Rate Time	Defect Code	Symptom Code	Template ID	Failed Part Number
1103A8	Adjust the valves.	2.4 hr	6T600	NCX00	A23010A	31200-5J2-A53

### Pilot:

Operation Number	Description	Flat Rate Time	Defect Code	Symptom Code	Template ID	Failed Part Number
1103A8	Adjust the valves.	2.2 hr	6T600	NCX00	A23010B	31200-5J2-A53

### Ridgeline:

Operation Number	Description	Flat Rate Time	Defect Code	Symptom Code	Template ID	Failed Part Number
1103A8	Adjust the valves.	2.3 hr	6T600	NCX00	A23010C	31200-5J2-A53

## INSPECTION PROCEDURE

Does 23-008 Product Update: PGM-FI Idle Stop Software Update apply to the VIN?

Yes – Confirm 23-008 Product Update: PGM-FI Idle Stop Software Update is closed by checking VIN inquiry.

- If closed, verify the symptom, if present, proceed to the repair procedure.
- If open, do 23-008 Product Update: PGM-FI Idle Stop Software Update. Repair is complete.

No – Verify the symptom, if present, proceed to the repair procedure.

## REPAIR PROCEDURE

1. Disconnect the front HO2S connector.

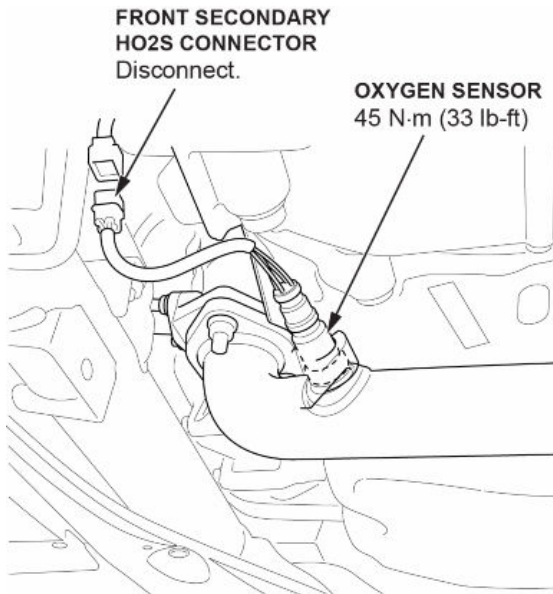

2. Remove the front bulkhead cover.

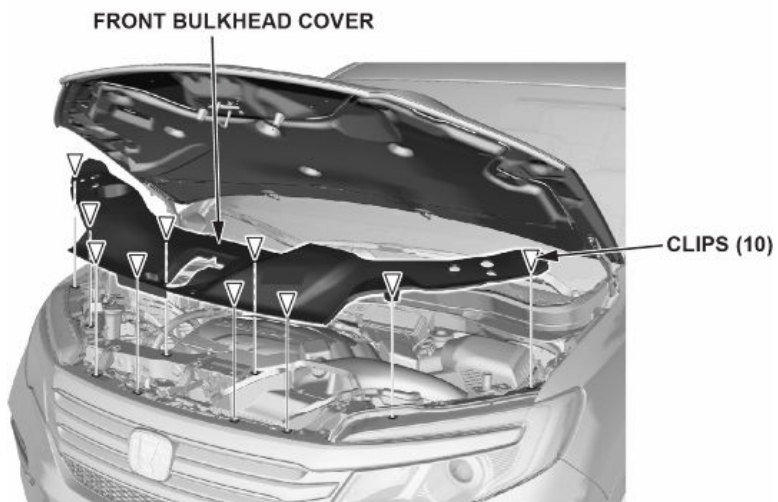

3. Remove the engine cover.

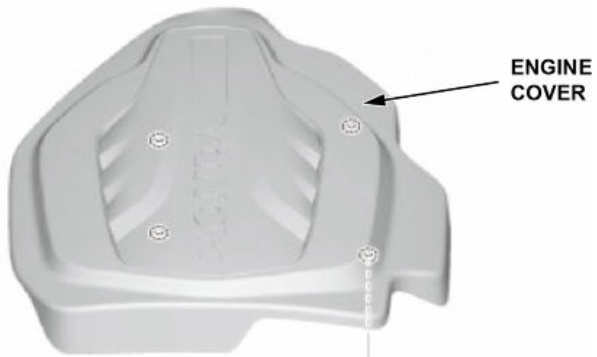

4. Remove the air intake tube.

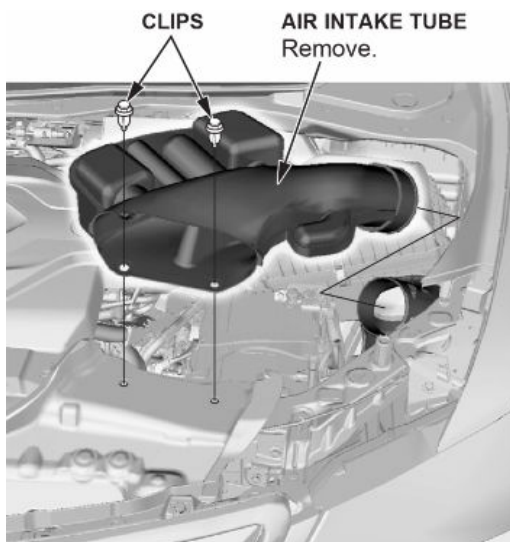

5. Remove Intake air duct, disconnect the connectors, and harness clip.

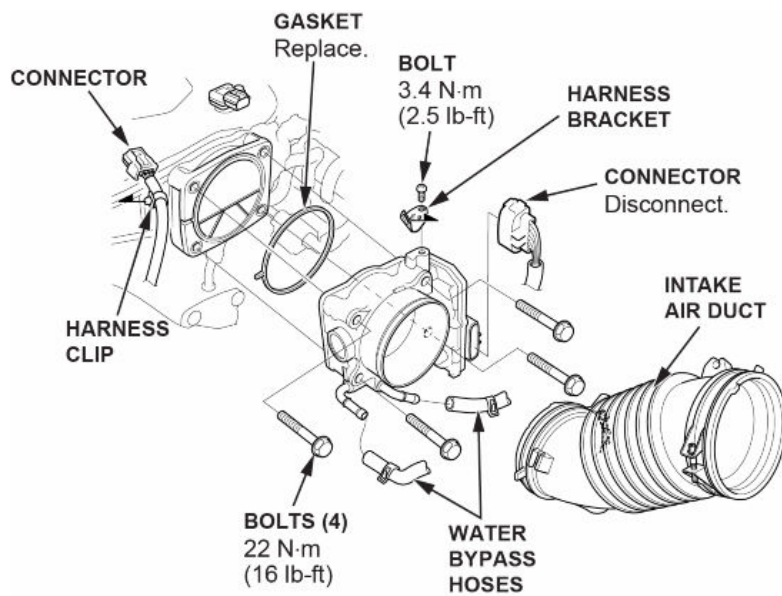

6. Disconnect the connectors and EVAP purge hose. Move the throttle body with the water bypass hoses connected.  
NOTE: The throttle body gasket is a must replace item.

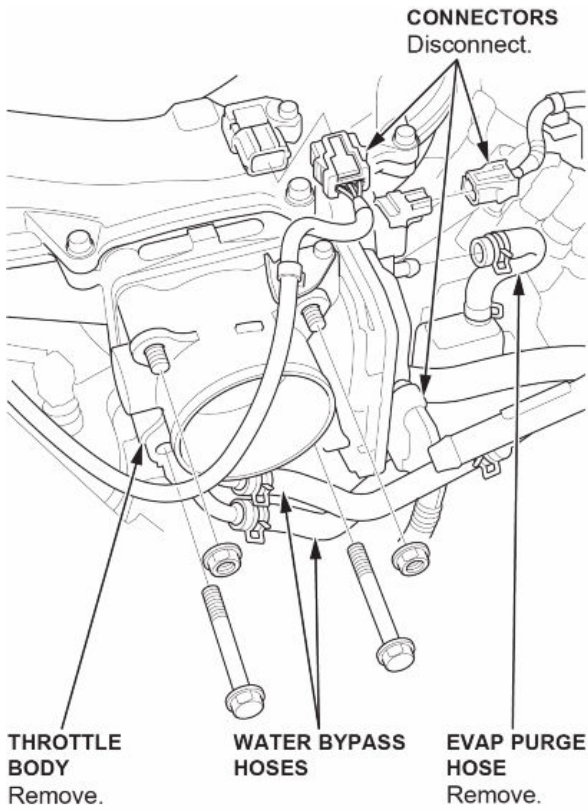

7. Disconnect the PCV hose and the brake booster vacuum hose.

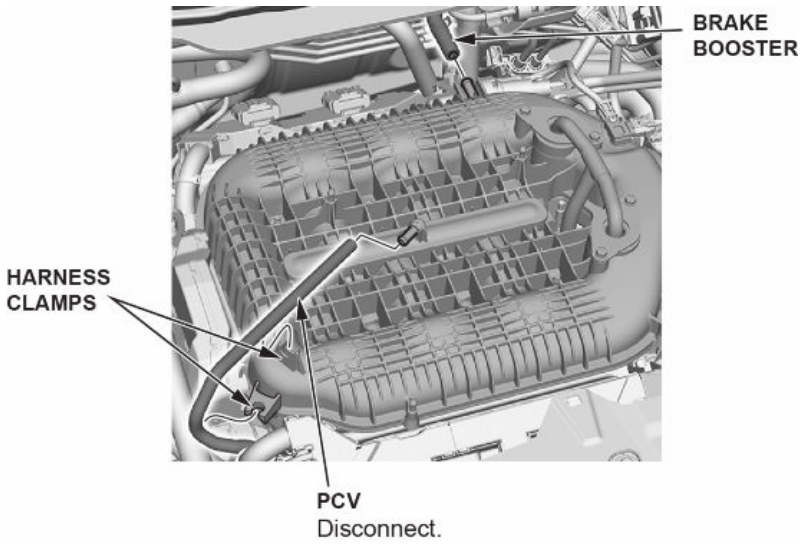

8. Remove the EGR pipe B.

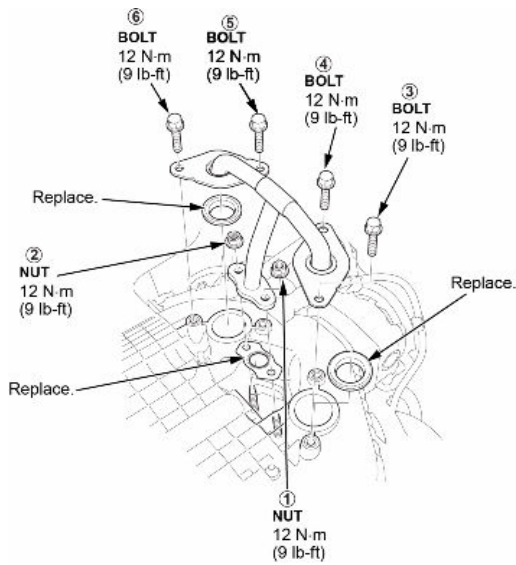

9. Remove the upper cover mounting bolts and nuts sequentially in three steps. Remove the intake manifold.

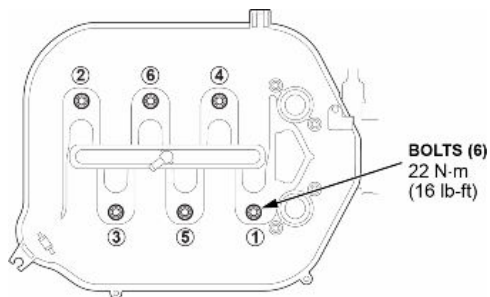

10. Remove the ignition coils, connectors, and the positive alternator cable.

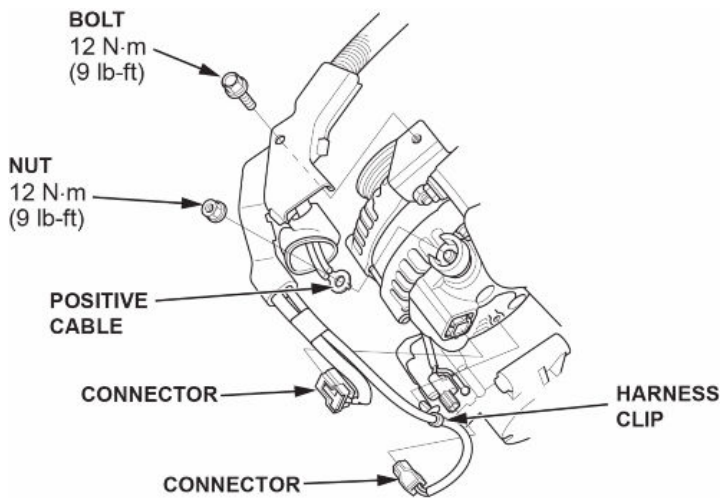

11. Disconnect the rocker arm oil pressure sensor.

12. Remove the harness holders on both cylinder heads.

13. Remove cylinder head covers.

NOTE: Connect the HDS to the DLC and monitor ECT SENSOR 1. When the engine has cooled down and the coolant temperature is less than 100°F (38°C), adjust the valve clearance.

14. Set the No. 1 piston at top dead center (TDC). Align the pointer on the front upper cover with the No. 1 piston TDC mark on the front camshaft pulley.

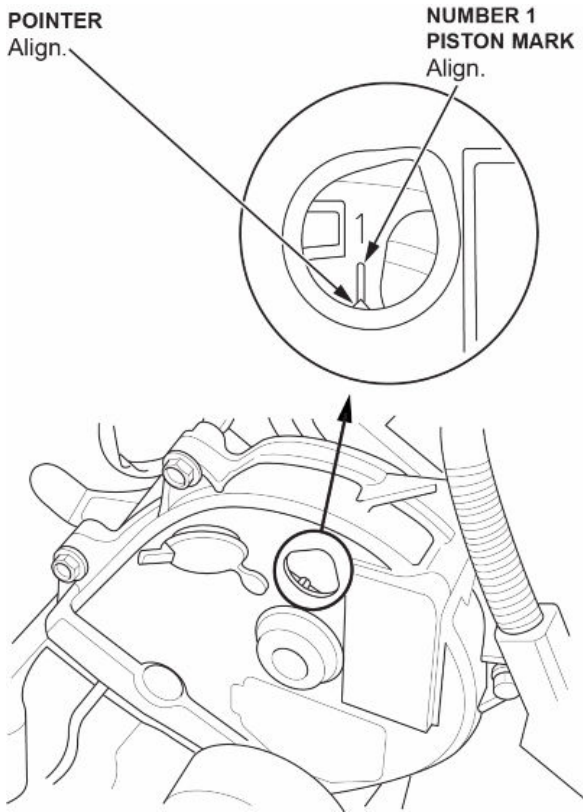



15. Select the correct feeler gauge for the valve clearance you are going to check.

Valve Clearance Spec:

- **Intake: 0.20-0.24 mm (0.008-0.009 in)**
- **Exhaust: 0.28-0.32 mm (0.011-0.012 in)**

For this repair, you'll set the valve clearance to these specs:

- **Intake .22 mm**
- **Exhaust .30 mm**

**REAR**

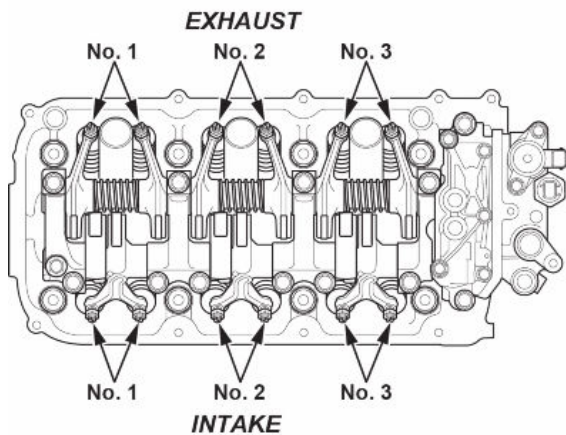

**FRONT**

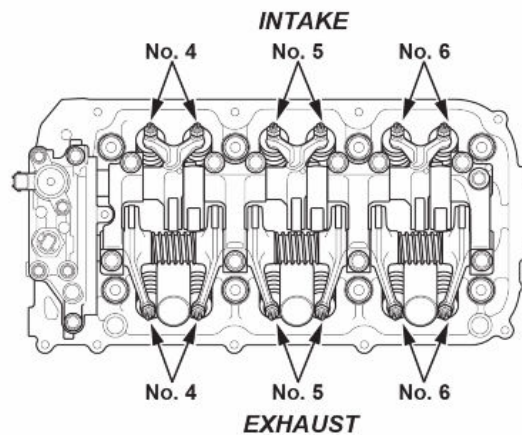

16. Insert the feeler gauge between the adjusting screw and the end of the valve stem on the No. 1 cylinder and slide it back and forth; you should feel a slight amount of drag.

**INTAKE**

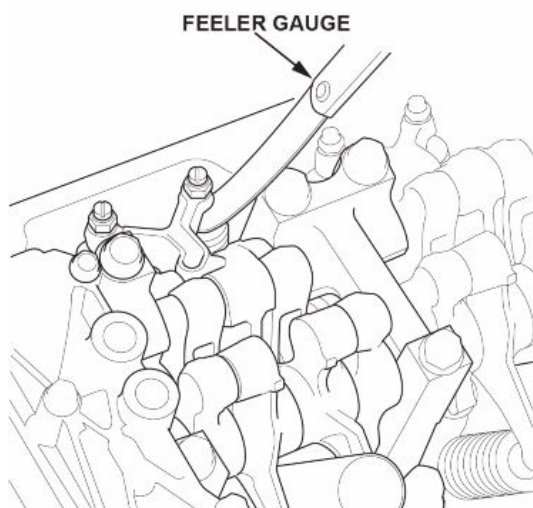

**EXHAUST**

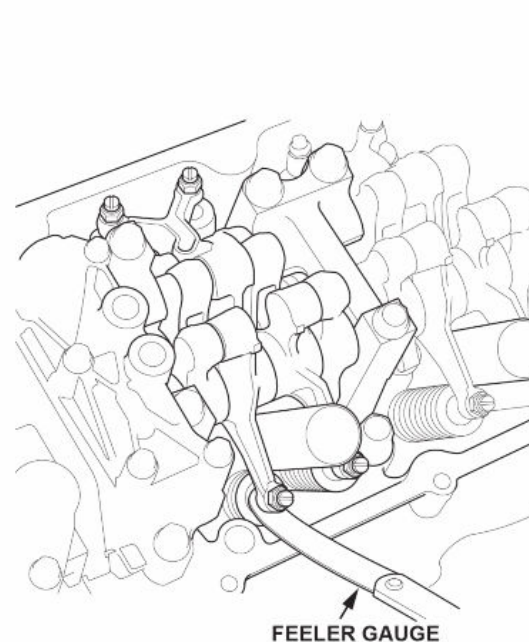

17. If you feel too much or too little drag, loosen the locknut, then turn the adjusting screw until the drag on the feeler gauge is correct.



18. While holding the adjusting screw with the screwdriver, tighten the locknut, then recheck the clearance. Repeat the adjustment, if necessary.

Specified Torque:

**Intake: 20 N·m (15 lb-ft)**

**Exhaust: 20 N·m (15 lb-ft)**

Apply new engine oil to the nut threads.

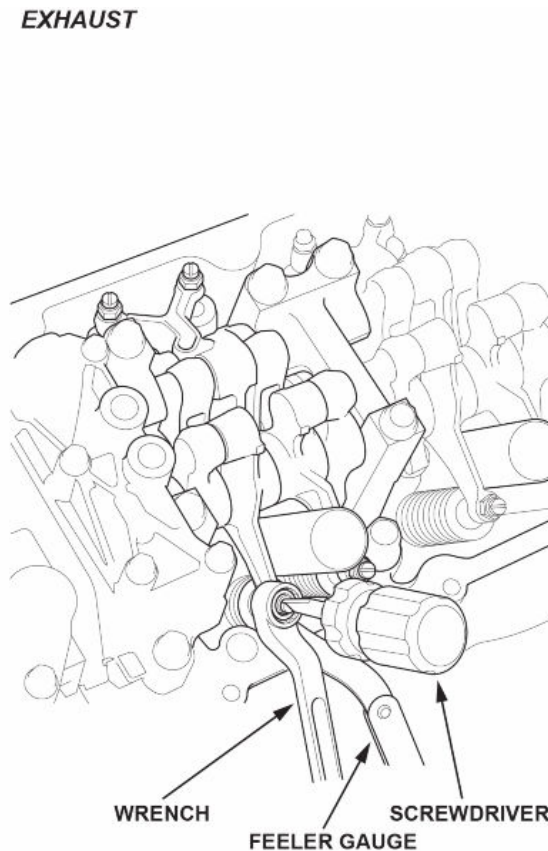
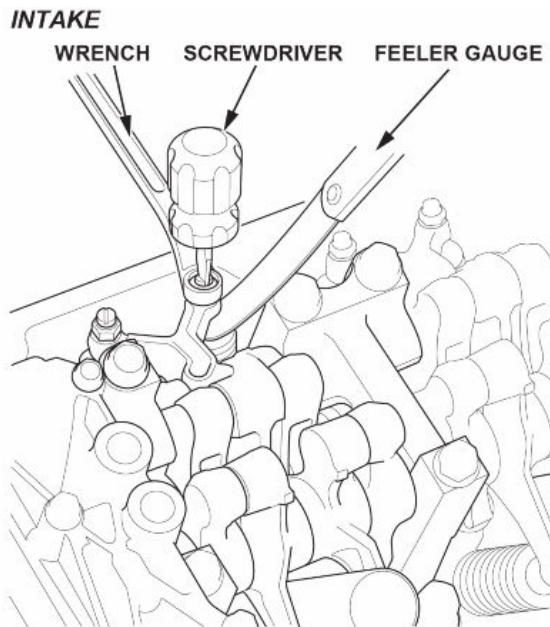

19. Rotate the crankshaft clockwise. Align the pointer on the front upper cover with the No. 4 piston TDC mark on the front camshaft pulley.

20. Check, and if necessary, adjust the valve clearance on the No. 4 cylinder.

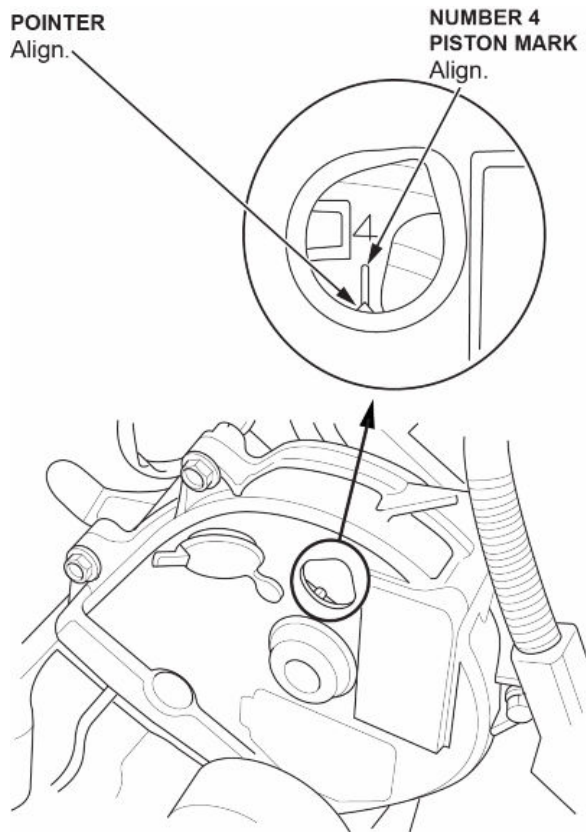

21. Rotate the crankshaft clockwise. Align the pointer on the front upper cover with the No. 2 piston TDC mark on the front camshaft pulley.

22. Check, and if necessary, adjust the valve clearance on the No. 2 cylinder.

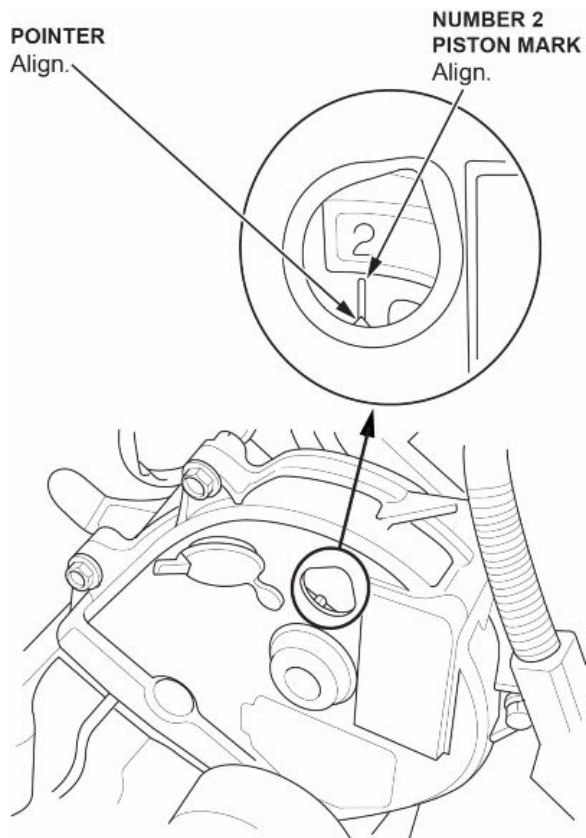

23. Rotate the crankshaft clockwise. Align the pointer on the front upper cover with the No. 5 piston TDC mark on the front camshaft pulley.

24. Check, and if necessary, adjust the valve clearance on the No. 5 cylinder.

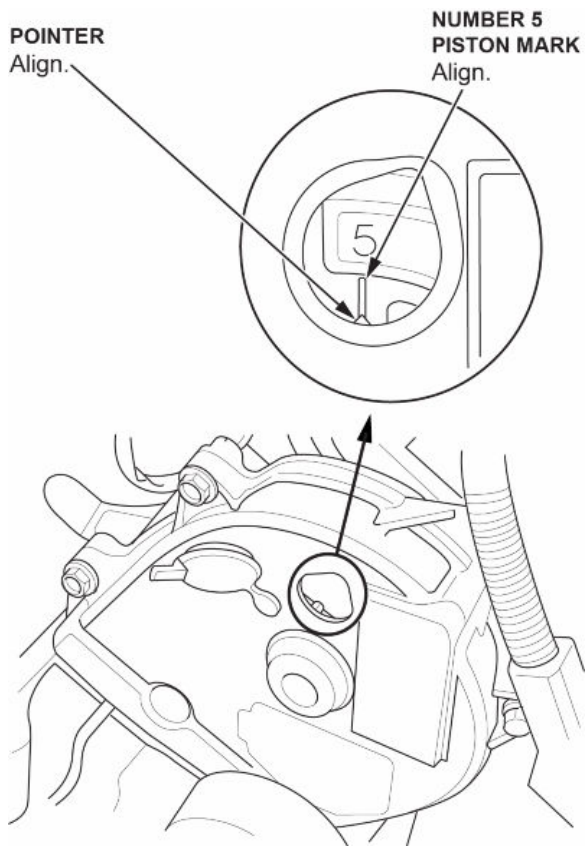

25. Rotate the crankshaft clockwise. Align the pointer on the front upper cover with the No. 3 piston TDC mark on the front camshaft pulley.

26. Check, and if necessary, adjust the valve clearance on the No. 3 cylinder.

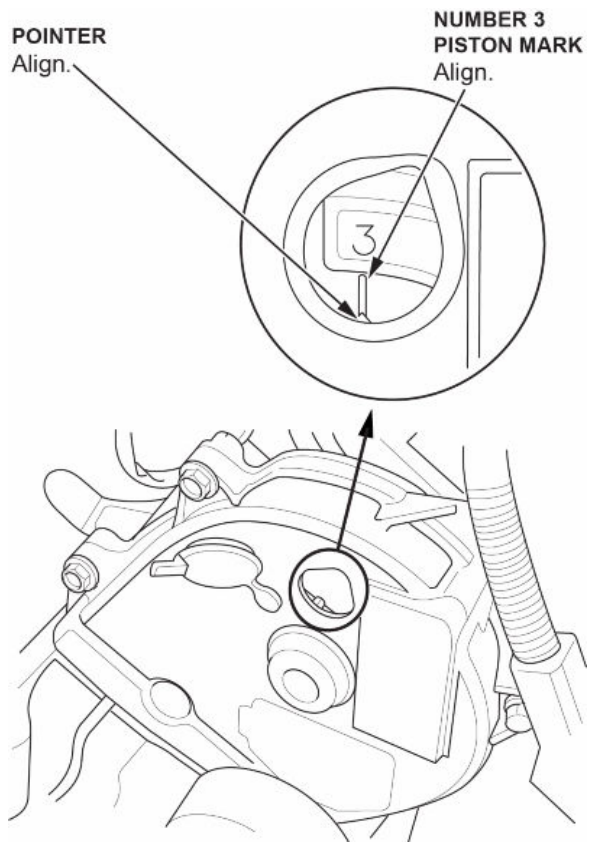

27. Rotate the crankshaft clockwise. Align the pointer on the front upper cover with the No. 6 piston TDC mark on the front camshaft pulley.

28. Check, and if necessary, adjust the valve clearance on the No. 6 cylinder.

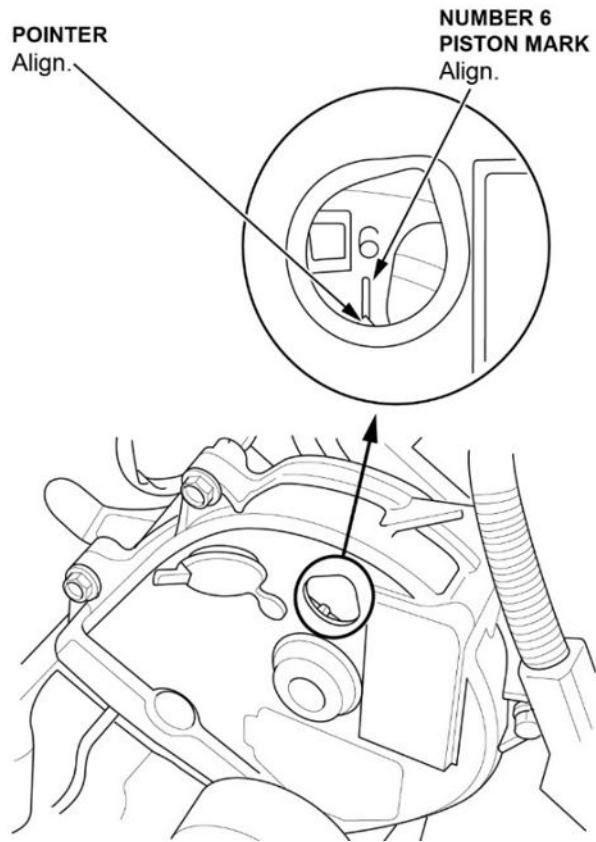

29. Check the spark plug seals for damage. If any seals are damaged, replace it.

30. Thoroughly clean the head cover gasket and the groove of the cylinder head cover.

NOTE: Check and if necessary, replace the head cover gasket.

31. Install the head cover gasket in the groove of the cylinder head cover. Make sure the head cover gasket is seated securely.

32. Remove all of the old liquid gasket from the front and rear rocker arm oil control valve mating surfaces then apply new liquid gasket.

FRONT ROCKER ARM OIL CONTROL VALVE

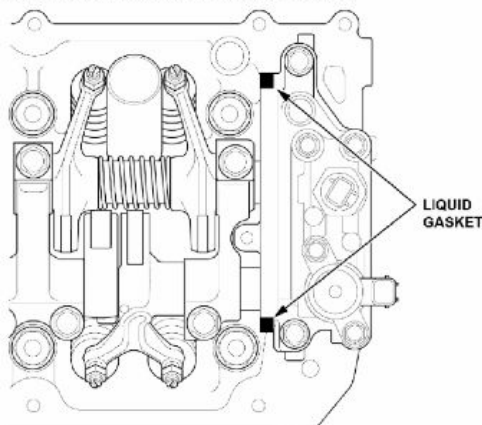

REAR ROCKER ARM OIL CONTROL VALVE

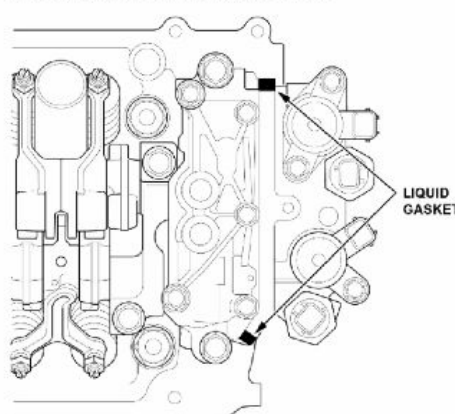

33. Set the spark plug seals on the spark plug tubes and install the front and rear cylinder head cover.

34. Inspect the spark plug seals for damage.



35. Reinstall the remaining parts in the reverse order of removal.

- When installing the intake manifold, make sure to tighten the bolts/nuts in three steps.
- When installing the throttle body, tighten in a cross pattern in three steps.
- When installing the intake air duct do not over-tighten the hose band screw.

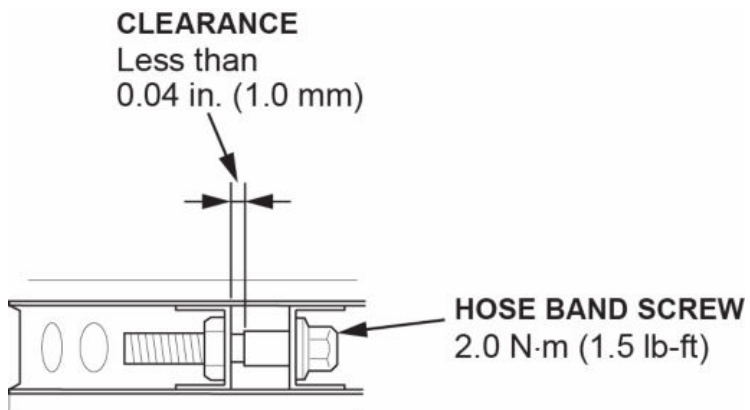

END