



STAR ONLINE PUBLICATION



Case Number: S2219000007

Release Date: December 2022

Symptom/Vehicle Issue: Service Electric Power Steering (EPS) Message Displayed on Cluster Upon Start Up

Customer Complaint/Technician Observation: Owner complains of a cluster message to service the EPS system shortly after starting the vehicle. Technician observed the Diagnostic Trouble Codes (DTCs) C2217-00 EPS Module Internal, and C1592-00 EPS Motor Circuit were set at the same time, within the same ignition cycle.

Discussion: When the above DTCs are setting as described above, it is best to check the battery charge level (charge as needed) and then check the EPS redundant B+ feeds and grounds (G905a G906A) for any voltage drop prior to any further repairs, Fig 1 and 2.

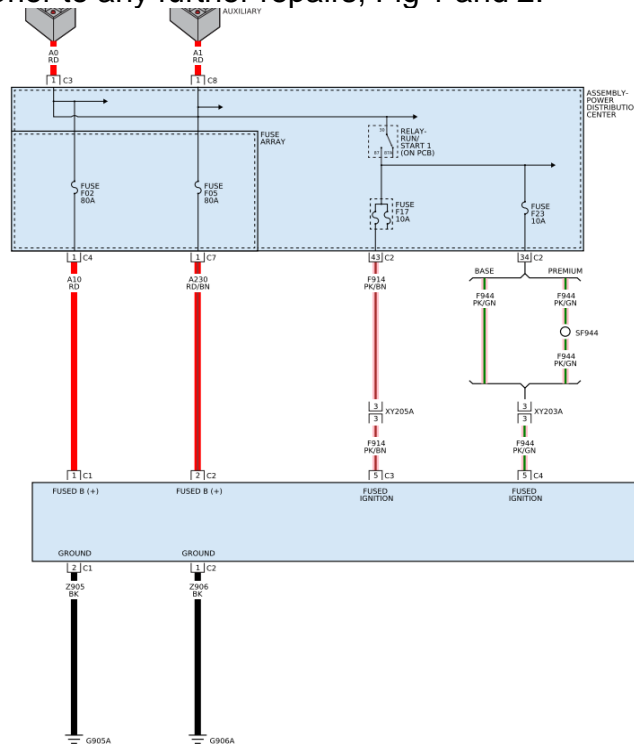

Fig 1

This document does not authorize warranty repairs. This communication documents a record of past experiences. STAR Online does not provide any conclusions about what is wrong with the vehicle. Rather, it captures all previous cases known that appear to be similar or related to the vehicle symptom / condition. You are the expert, and you are responsible for deciding on the appropriate course of action.

Contact STAR Center, or your Technical Assistance Center Via TechCONNECT or eCONTACT ticket if no solution is found



STAR ONLINE PUBLICATION

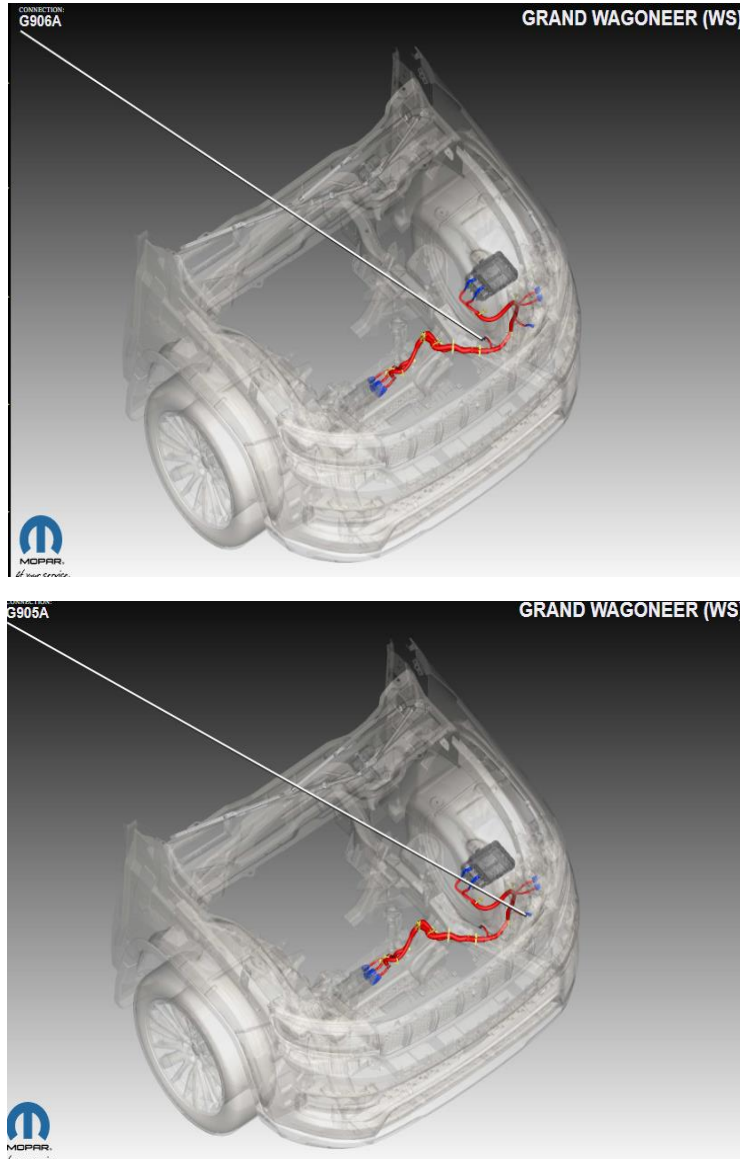

Fig 2

This document does not authorize warranty repairs. This communication documents a record of past experiences. STAR Online does not provide any conclusions about what is wrong with the vehicle. Rather, it captures all previous cases known that appear to be similar or related to the vehicle symptom / condition. You are the expert, and you are responsible for deciding on the appropriate course of action.

Contact STAR Center, or your Technical Assistance Center Via TechCONNECT or eCONTACT ticket if no solution is found