

December 2022  
SF660A

## Subject: Drag Link Tapered Joint

**Models Affected: Specific model years 2019-2021 Freightliner 108SD, 114SD, 122SD, Business Class M2, Cascadia, Columbia, and Coronado vehicles manufactured April 2, 2018, through June 25, 2020.**

### General Information

Daimler Truck North America LLC (DTNA), on behalf of its Freightliner Trucks Division, is initiating Field Service Campaign SF660 to modify the vehicles mentioned above.

On certain vehicles, the drag link tapered joint, at the steering arm, may not have been tightened to manufacturer specification and may come loose. A loose drag link tapered joint at the steering arm may result in separation of the joint leading to a complete loss of steering, which could lead to a crash.

The drag link will be inspected and torqued to specification. Repairs will be performed by Daimler Trucks North America authorized service facilities.

There are approximately 59,039 vehicles involved in this campaign.

**NOTE:** Only approximately 2% replacement is expected. Please do not overstock replacement parts.

#### Additional Repairs

Dealers must complete all outstanding Recall and Field Service campaigns prior to the sale or delivery of a vehicle. A Dealer will be liable for any progressive damage that results from its failure to complete campaigns before sale or delivery of a vehicle.

Owners may be liable for any progressive damage that results from failure to complete campaigns within a reasonable time after receiving notification.

Please contact Warranty Campaigns for consideration of additional charges prior to performing the repair.

### Work Instructions

Please refer to the attached work instructions. Prior to performing the campaign, check the vehicle for a completion sticker (Form WAR261).

### Replacement Parts

Replacement parts are now available and can be obtained by ordering the kit and/or part number(s) listed below from your facing Parts Distribution Center.

If our records show your dealership has ordered any vehicle(s) involved in campaign number SF660, a list of the customers and vehicle identification numbers will be available on DTNAConnect. Please refer to this list when ordering parts for this campaign.

**Table 1** - Replacement Parts for SF660

**NOTE: Only approximately 2% replacement is expected. Please do not overstock replacement parts.**

Campaign Number	Procedure	Part Description	Part Number	Qty.
SF660A	Inspect castle nut and torque	PIN-COTTER, 1 3/4 X 1/8	23-00800-407	1 ea
		BLANK COMPLETION STICKER	WAR261	1 ea

December 2022  
SF660A

Campaign Number	Procedure	Part Description	Part Number	Qty.
SF660A Replacement Procedure Only 2% will fall into this category	Replace drag link and steering arm Choose appropriate drag link, PLUS Completion Sticker	LINK-STEERING,DRAGLINK-, T65,1.04,31.47	14-17273-000	1 ea
		DRAGLINK-STRG, THP60,M2,10	14-17288-000	1 ea
		LINK-STEERING,DRAGLINK-,M2, THP60,100BBC	14-17289-000	1 ea
		LINK-STEERING,DRAGLINK-, TAS85,M2,106,131	14-17290-000	1 ea
		LINK-STEERING,DRAGLINK-, TAS85,M2,106,131	14-17291-000	1 ea
		LINK-STEERING,DRAGLINK-, TAS85,M2,106,162	14-17293-000	1 ea
		ARM-DRAGLINK, STEERING,D2, 1400, DUAL,RHS	14-17294-000	1 ea
		ARM-DRAGLINK, STEERING,D2, 1400,DUAL,LHS	14-17295-000	1 ea
		ARM-DRAGLINK,STEERING, RCH45,SFA,1200	14-17296-000	1 ea
		ARM-DRAGLINK,STEERING,D2, FA,1200,THP60	14-17297-000	1 ea
		LINK-STEERING,DRAGLINK-COMMON, SFA,THP60	14-17298-000	1 ea
		ARM-DRAGLINK,STEERING, COMMON,SB,TAS85,FG	14-17299-000	1 ea
		ARM-DRAGLINK,COMMON, SFA,TAS85,FL,1200	14-17300-000	1 ea
		ARM-DRAGLINK,STEERING, COMMON,SB,TAS85,FL	14-17301-000	1 ea
		ARM-DRAGLINK,STEERING, COMMON,SB,THP60,DB	14-17302-000	1 ea
		ARM-DRAGLINK,COMMON, SFA,T60,LWB	14-17303-000	1 ea
		ARM-DRAGLINK,STG,LC,111,1400,THP60	14-17310-000	1 ea
		ARM-DRAGLINK,STEERING, M2,106,THP60,20K	14-17311-000	1 ea
LINK-STEERING,DRAGLINK-, COMMON,SBA,T60,2	14-17317-000	1 ea		
LINK-STEERING,DRAGLINK-, COMMON,SBA,RCH45	14-17318-000	1 ea		
SF660A Replacement Procedure Only 2% will fall into this category	Replace drag link and steering arm Vehicles with Hendrickson steering arms, choose appropriate steering arm, PLUS hardware	STEERING ARM AY-LH	HDR60903 435	1 ea
		STEERING ARM AY-LH	HDR60903 436	1 ea
		STEERING ARM AY-LH	HDR60903 438	1 ea
		STEERING ARM AY	HDR60903 439	1 ea
		STEERING ARM ASSEMBLY LH	HDR60903 473	1 ea
		5/8-11 SOCKET CAP	HDR 60236 001	2 ea
		PIN-COTTER,1 3/4 X 1/8	23-00800-407	2 ea

December 2022  
SF660A

Campaign Number	Procedure	Part Description	Part Number	Qty.
SF660A Replacement Procedure Only 2% will fall into this category	<b>Replace drag link and steering arm</b> Vehicles with Detroit steering arms, choose appropriate steering arm and capscrew, PLUS cotter pin	STEERING ARM	MBA 6803382101	1 ea
		STEERING ARM	MBA 6803380201	1 ea
		ARM-STEERING	MBA 6803382501	1 ea
		STEERING ARM	MBA 6803380401	1 ea
		STEERING ARM	MBA 6803380901	1 ea
		STEERING ARM	MBA 6803381601	1 ea
		STEERING ARM (14.7K GAWR)	MBA 6803384401	1 ea
		ARM, L. H. STEERING	MBA 6803382203	1 ea
		ARM, L. H. STEERING	MBA 6803382603	1 ea
		STEERING ARM LH LARGE TAPER UP IN KM	MBA 6803382303	1 ea
		STEERING ARM,LH	MBA 6803382403	1 ea
		ARM, R. H. STEERING	MBA 6803383203	1 ea
		ARM, R. H. STEERING	MBA 6803383603	1 ea
		R.H. STEERING ARM	MBA 6803381402	1 ea
		STRG ARM,RH	MBA 6803383403	1 ea
		STEERING ARM, M2	MBA 6813380001	1 ea
		STEERING ARM, M2	MBA 6803381801	1 ea
		STEERING ARM, M2	MBA 6813380201	1 ea
		STEERING ARM, M2	MBA 6803382001	1 ea
		ARM, STEERING M3	MBA 6803382301	1 ea
		STEERING ARM, M3	MBA 6813380901	1 ea
		STEERING ARM, M3	MBA 6803382701	1 ea
		STEERING ARM, 14.7K	MBA 6803382901	1 ea
		STEERING ARM RH	MBA 6803380502	1 ea
		STEERING ARM LH	MBA 6803384503	1 ea
		STEERING ARM LH	MBA 6803384403	1 ea
		STEERING ARM RH	MBA 6803380402	1 ea
		STEERING ARM	MBA 6813381001	1 ea
STEERING ARM 430 RH NGC	MBA 6803385603	1 ea		
STEERING ARM 390 RH	MBA 6813381101	1 ea		
SCREW,M20X1.5X80-10.9	MBA 308676020025	2 ea		
SCREW M24X2X90	MBA 308676024001	2 ea		
PIN-COTTER,1 3/4 X 1/8	23-00800-407	2 ea		

December 2022  
SF660A

Campaign Number	Procedure	Part Description	Part Number	Qty.
SF660A Replacement Procedure Only 2% will fall into this category	Replace drag link and steering arm Vehicles with Meritor steering arms, choose appropriate steering arm, PLUS hardware	ARM & KEYS	TDA3133Z7696K	1 ea
		ARM AND KEYS	TDA3133N7736K	1 ea
		ARM-TIE ROD ARM-STEERING	TDA3133S8963	1 ea
		ARM-STRG	TDA3133S8963F	1 ea
		ARM-STEERING	TDA3133W8967	1 ea
		ARM-STEERING	TDA3133E8403	1 ea
		ARM-STRG	TDA3133S8417F	1 ea
		STRG ARM LH	TDA3133E8403F	1 ea
		ARM-STEERING,LH	TDA3133E7779	1 ea
		ARM-STEERING LH	TDA3133B8582	1 ea
		ARM-STEERING,RH	TDA3133C8609	1 ea
		ARM-STEERING	TDA3133E8611	1 ea
		ARM-STEERING	TDA3133G8743	1 ea
		ARM-STEERING,LH	TDA3133L8618	1 ea
		STEERING ARM	TDA3133U8679	1 ea
		ARM STEERING ASSEMBLY, RIGHT HAND	TDA3133V8680	1 ea
		ARM STEERING LH	TDA3133E8455F	1 ea
		ARM-STEERING	TDA3133G8457F	1 ea
		ARM STEERING LH	TDA3133D8454F	1 ea
		ARM-STEERING,FRONT AXLE,RH	TDA3133E9287	1 ea
		ARM-STEERING,FRONT AXLE,LH	TDA3133F9288	1 ea
		ARM-STEERING,LH	TDA3133D9286	1 ea
		ARM-STEERING,LH	TDA3133C9285	1 ea
ARM-STEERING, LH	TDA3133F9470	1 ea		
ARM-STEERING, LH	TDA3133H9472	1 ea		
ARM-STEERING, LH	TDA3133Q9403	1 ea		
PIN-COTTER	TDA K2618	1 ea		
NUT-STEERING ARM	TDA 1227Y1715	1 ea		
PIN-COTTER,1 3/4 X 1/8	23-00800-407	2 ea		

## Removed Parts

U.S. and Canadian Dealers, please follow Warranty Failed Parts Tracking shipping instructions for the disposition of all removed parts. Export distributors, please destroy removed parts unless otherwise advised.

## Labor Allowance

Table 2 - Labor Allowance

Campaign Number	Procedure	Time Allowed (hours)	SRT Code	Corrective Action
SF660A	Inspect drag link and torque	0.4	996-F134A	06-Inspect
SF660A	Inspect drag link and torque; replace drag link and steering arm	2.1	996-F134B	12-Repair Recall/Campaign

**IMPORTANT:** When the campaign has been completed, locate the base completion label in the appropriate location on the vehicle, and attach the gray completion sticker provided in the field service kit (Form WAR261). If the vehicle does not have a base completion label, clean a spot on the appropriate location of the vehicle and first attach the base completion label (Form WAR259). If a field service kit is not required or there is no completion sticker in the kit, write the campaign number on a blank sticker and attach it to the base completion label.

December 2022  
SF660A

## Claims for Credit

You will be reimbursed for your parts, labor, and handling (landed cost for Export Distributors) by submitting your claim through the Warranty system within 30 days of completing this campaign. Please reference the following information in OWL:

- Claim type is **Field Service Campaign**.
- In the Campaign field, enter the campaign number and appropriate condition code (**SF660-A**).
- In the Primary Failed Part field, enter **25-SF660-000**.
- In the Parts section, enter the appropriate kit or part number(s) as shown in the Replacement Parts Table.
- In the Labor section, enter the appropriate SRT from the Labor Allowance Table. Administrative time will be included automatically as SRT 939-6010A for 0.3 hours.
- The VMRS Component Code is **F99-999-005** and the Cause Code is **A1 - Campaign**.
- This Field Service Campaign will **terminate on December 31, 2023**. Dealers will be notified of any changes to the termination date via Important Campaign Information Letter posted on DTNAConnect.com.

**IMPORTANT:** OWL must be viewed prior to beginning work to ensure the vehicle is involved and the campaign has not previously been completed. Also, check for a completion sticker before beginning work.

All claims must be submitted within 30 days of the repair and within 30 days of the termination date of the campaign. U.S. and Canadian Dealers: All excess inventory to be returned to the PDC following the conclusion of the campaign must be returned in resaleable condition to the Memphis PDC within 90 days from the termination date. Please submit a PAR to request return to the Memphis PDC. (Canadian dealers should return the kits to their facing PDC.) Export Distributors: Excess inventory may be returned as noted for U.S. and Canadian dealers. Export locations will pay freight to return kits. Export Distributors: Excess inventory is not returnable.

For questions, U.S. and Canadian dealers, contact the Warranty Campaigns Department via Web inquiry at DTNAConnect.com/WSC, or the Customer Assistance Center at (800) 385-4357, if you have any questions or need additional information. Export distributors submit a Web inquiry or contact your International Service Manager.

December 2022  
SF660A

## Copy of Notice to Owners

### Subject: Drag Link Tapered Joint

Daimler Trucks North America LLC (DTNA), on behalf of its Freightliner Trucks Division, is initiating Field Service Campaign SF660 to modify specific model years 2019-2021 Freightliner 108SD, 114SD, 122SD, Business Class M2, Cascadia, Columbia, and Coronado vehicles manufactured April 2, 2018, through June 25, 2020.

On certain vehicles, the drag link tapered joint, at the steering arm, may not have been tightened to manufacturer specification and may come loose. A loose drag link tapered joint at the steering arm may result in separation of the joint leading to a complete loss of steering, which could lead to a crash.

The drag link will be inspected and torqued to specification. Repairs will be performed by Daimler Trucks North America authorized service facilities.

Please contact an authorized DTNA dealer to arrange to have the campaign performed and to ensure that parts are available at the dealership. The campaign will take approximately two hours and will be performed at no charge to you. To locate an authorized dealer, search online at [NorthAmerica.DaimlerTruck.com/contact-us/](http://NorthAmerica.DaimlerTruck.com/contact-us/). Scroll down to "Locate a Dealer," and select the appropriate brand.

This Field Service Campaign will **terminate on December 31, 2023**. Please make sure the campaign is completed prior to this date. Work completed after this date will be done at the customer's expense.

As stated in the terms of your express limited warranty, DTNA will not pay for any damage caused by failure to properly maintain your vehicle. DTNA considers the work necessary under this campaign to be proper maintenance and will, therefore, not pay for any damage to your vehicle caused by your failure to have the repairs that are the subject of this campaign performed in a reasonable time.

Contact the Warranty Campaigns Department at (800) 547-0712, from 7 a.m. to 4 p.m. Pacific Time, Monday through Friday, e-mail address [DTNA.Warranty.Campaigns@Daimlertruck.com](mailto:DTNA.Warranty.Campaigns@Daimlertruck.com), or the Customer Assistance Center at (800) 385-4357, if you have any questions or need additional information.

WARRANTY CAMPAIGNS DEPARTMENT

Enclosure

December 2022  
SF660A

## Work Instructions

### Subject: Drag Link Tapered Joint

**Models Affected:** Specific model years 2019-2021 Freightliner 108SD, 114SD, 122SD, Business Class M2, Cascadia, Columbia, and Coronado vehicles manufactured April 2, 2018, through June 25, 2020.

### Castle Nut Inspection and Tightening

NOTE: This procedure will require two people—one in the cab to turn the steering wheel, and one to observe the drag link steering arm joint as the steering wheel is turned.

1. Check the base label (Form WAR259) for a completion sticker for SF660 (Form WAR261) indicating this work has been done. The base label is usually located on the passenger door about 12 inches (30 cm) below the door latch. If a sticker is present, no work is needed. If there is no sticker, proceed with the next step.
2. Park the vehicle on a level surface, shut down the engine, and set the parking brake. Chock the rear tires.
3. Open the hood.
4. Observe the behavior of the drag link steering arm joint. See [Fig. 1](#).

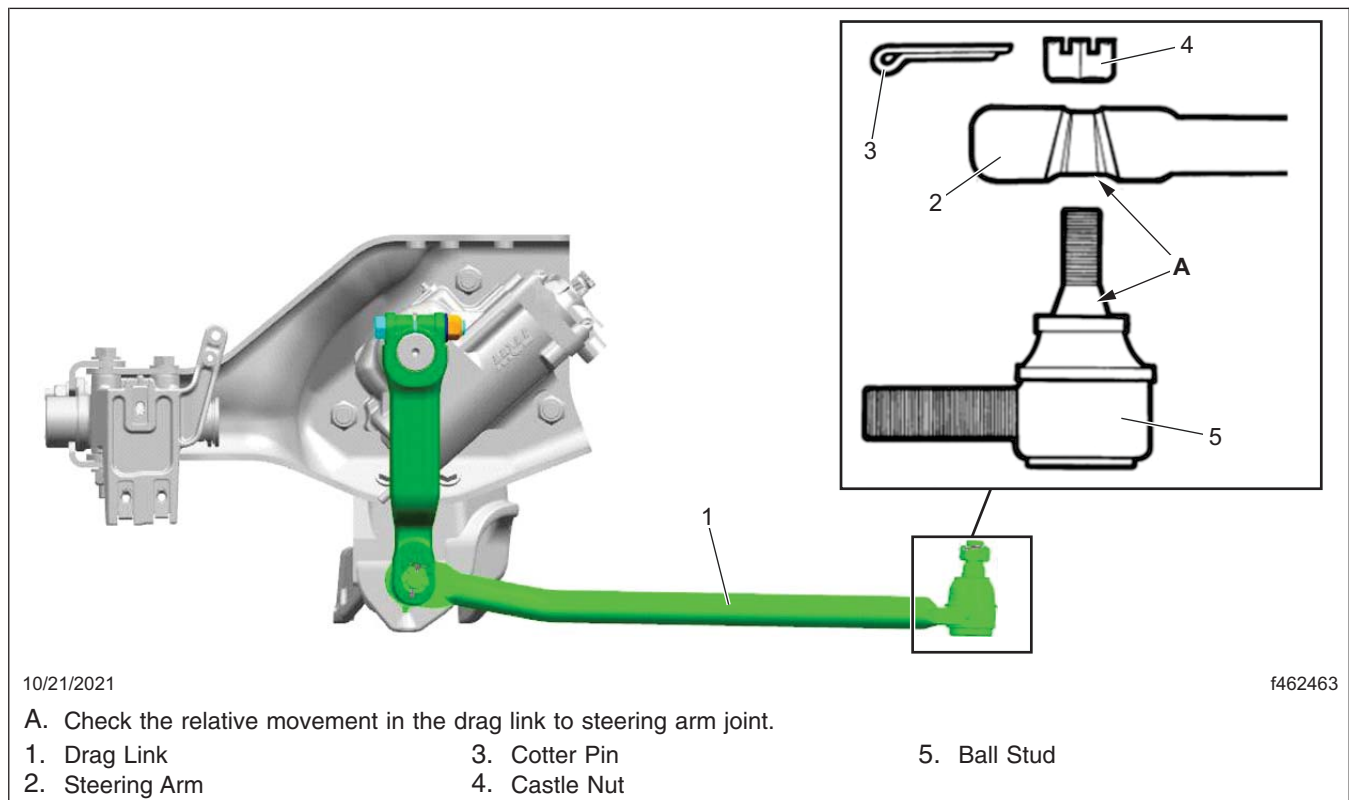

Fig. 1, Drag Link to Steering Arm Joint

December 2022  
SF660A

- 4.1 With the engine running at idle, and the parking brake still engaged, have an assistant turn the steering wheel in small increments from left-to-right and back several times.

 **WARNING**

**Maintain a safe distance from the front tire and the moving steering linkage while observing.**

**Failure to maintain a safe distance could result in severe personal injury or death.**

- 4.2 While the steering wheel is being turned, check the behavior of the drag link to steering arm joint.
5. Are any of the following conditions observed?
- The castle nut appears to be loose.
  - The cotter pin is not in place.
  - There is relative movement in the drag link to steering arm joint when the steering wheel is moved back and forth.

**YES** → Go to the **Drag Link and Steering Arm Replacement** procedure.

**NO** → Go to the next step.

December 2022  
SF660A

**IMPORTANT:** Do not back off the castle nut to align its slots to the cotter pin hole on the ball stud. Further turn the castle nut a maximum of one-sixth of a turn to align it.

- Remove and discard the cotter pin from the castle nut at the drag link to steering arm joint, then tighten the castle nut to the torque value shown in **Table 1**. See **Fig. 2**.

Castle Nut Torque Values	
Size	Torque: lbf-ft (N·m)
3/4-16	117-143 (159-194)
7/8-14	207-253 (281-343)

**Table 1, Castle Nut Torque Values**

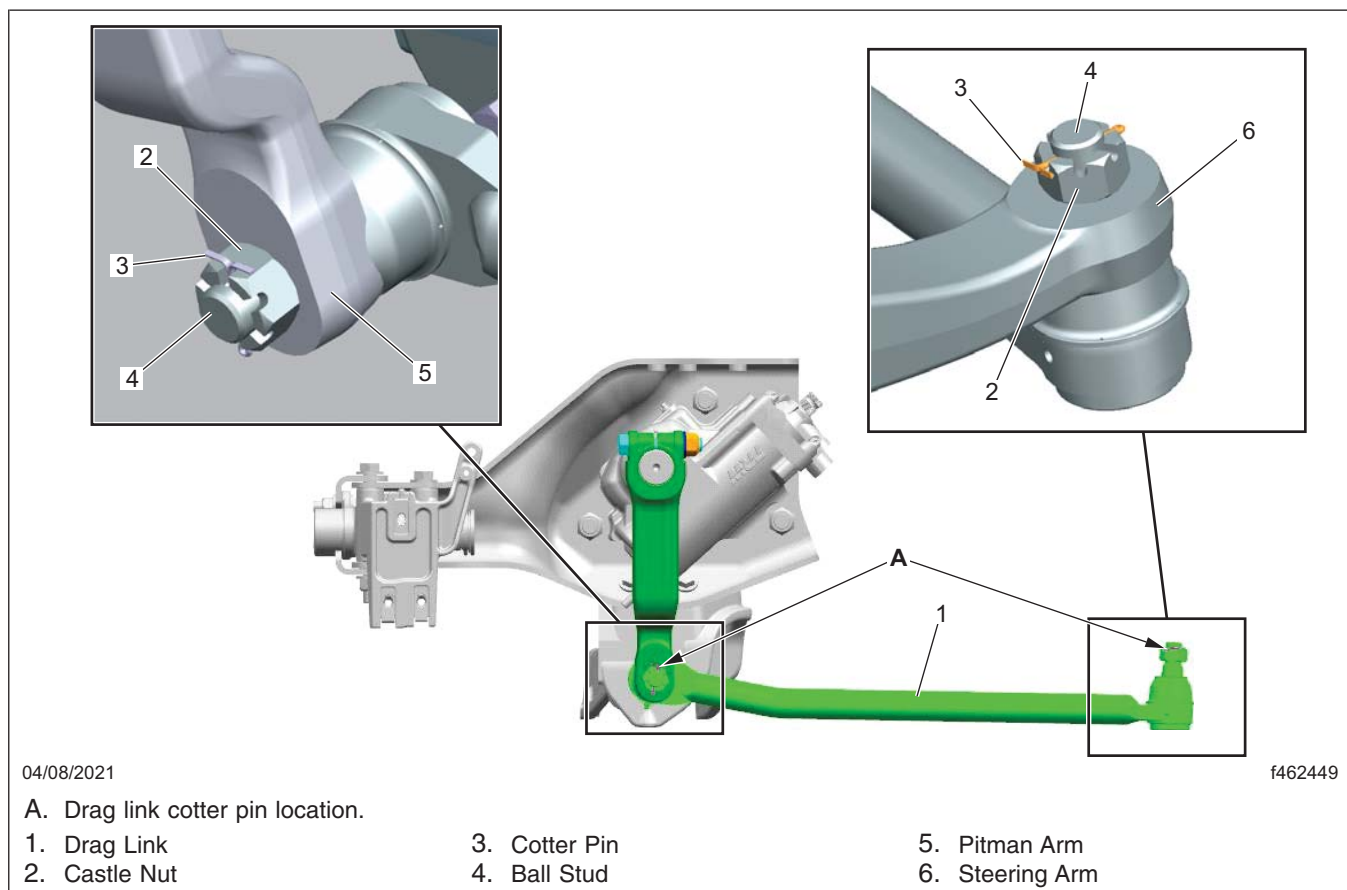

**Fig. 2, Drag Link Cotter Pin Location**

- Install and lock a new cotter pin on the drag link to steering arm joint.
- Clean a spot on the base label (Form WAR259), write the campaign number, SF660, on a blank red completion sticker (Form WAR260), and attach it to the base label, indicating this work has been completed.

December 2022  
SF660A

## Drag Link and Steering Arm Replacement

1. At both ends of the drag link, remove the cotter pins, then remove the castle nuts. See [Fig. 2](#). Discard the cotter pins and castle nuts.
2. Using a ball stud removal tool, remove the ball studs from the pitman arm and the steering arm.
3. Remove the drag link from the vehicle, and discard it.

4. **For Detroit® steering arm:**

- 4.1 Remove the capscrews that attach the steering arm to the knuckle, then remove the steering arm from the vehicle. Discard the steering arm and capscrews.
- 4.2 Position a new steering arm on the knuckle. Apply Loctite® 277 on the threads of the new steering arm capscrews, then install the capscrews.
  - If M20 capscrews are used, tighten them 425 lbf·ft (576 N·m).
  - If M24 capscrews are used, tighten them 664 lbf·ft (900 N·m).

5. **For Meritor steering arm:**

- 5.1 For non-drive front axles, remove the cotter pin and castle nut that attach the steering arm to the knuckle, then remove the steering arm from the vehicle. Discard the steering arm, castle nut and cotter pin.
- 5.2 Press the key into the slot in the arm, then install the new steering arm on the knuckle.

**IMPORTANT:** Do not back off the castle nut to align its slots to the cotter pin hole on the ball stud. Further turn the castle nut a maximum of one-sixth of a turn to align it.

- 5.3 Install a new castle nut TDA 1227Y1715. Tighten the nut 775 to 1450 lbf·ft (1051 to 1966 N·m). Install and lock a new cotter pin TDA K2618 on the castle nut.
- 5.4 For front drive axles, see Meritor MX-120/MX-120EVO Service Manual.
- 5.5 Remove the capscrews that attach the steering arm to the knuckle, then remove the steering arm from the vehicle. Discard the steering arm and capscrews.
- 5.6 Position a new steering arm on the knuckle, then install the new capscrews. Tighten the capscrews 500 to 650 lbf·ft (678 to 881 N·m).

6. **For Hendrickson steering arm:**

- 6.1 Remove the capscrews that attach the steering arm to the knuckle, then remove the steering arm from the vehicle. Discard the steering arm and capscrews.
- 6.2 Position a new steering arm on the knuckle, then install the new capscrews HDR 60236-001. Tighten the capscrews 176 to 200 lbf·ft (239 to 271 N·m).

7. Insert the steering arm ball stud of the new drag link assembly through the bottom of the steering arm, then install a new castle nut, and hand-tighten it.
8. Turn the steering wheel as needed to align the hole in the lower end of the pitman arm with the forward ball stud. Insert the ball stud in the pitman arm from the inboard side. Install a new castle nut, and hand-tighten it.

**IMPORTANT:** Do not back off the castle nut to align its slots to the cotter pin hole on the ball stud. Further turn the castle nut a maximum of one-sixth of a turn to align it.

9. Tighten the castle nuts to the torque value shown in [Table 1](#).
10. Install and lock a new cotter pin on the castle nuts at both ends of the drag link. See [Fig. 2](#).
11. Clean a spot on the base label (Form WAR259), write the campaign number, SF660, on a blank red completion sticker (Form WAR260), and attach it to the base label, indicating this work has been completed.