

December 2022
SF654A

Subject: Western Star Front Radar Mounting Bracket

Models Affected: Specific model years 2021-2023 Western Star 47X, 48X, and 49X vehicles manufactured October 9, 2020, through May 2, 2022.

General Information

Daimler Truck North America LLC (DTNA), on behalf of its wholly owned subsidiary, Western Star Trucks Sales Inc., is initiating Field Service Campaign SF654 to modify the vehicles mentioned above.

On specific vehicles, the front radar mounting bracket may cause false positive radar readings.

A new radar bracket will be mounted to the front of the bumper.

There are approximately 335 vehicles involved in this campaign.

Additional Repairs

Dealers must complete all outstanding Recall and Field Service campaigns prior to the sale or delivery of a vehicle. A Dealer will be liable for any progressive damage that results from its failure to complete campaigns before sale or delivery of a vehicle.

Owners may be liable for any progressive damage that results from failure to complete campaigns within a reasonable time after receiving notification.

Please contact Warranty Campaigns for consideration of additional charges prior to performing the repair.

Work Instructions

Please refer to the attached work instructions. Prior to performing the campaign, check the vehicle for a completion sticker (Form WAR261).

Replacement Parts

Replacement parts are now available and can be obtained by ordering the part number(s) listed below from your facing Parts Distribution Center.

If our records show your dealership has ordered any vehicle(s) involved in campaign number SF654, a list of the customers and vehicle identification numbers will be available on the DTNA Portal. Please refer to this list when ordering parts for this campaign.

Table 1 - Replacement Parts for SF654

Campaign Number	Part Description	Part Number	Qty.
SF654A	BRKT-RDR,VOC,STANDARD TOW	A15-30128-000	1 ea
	BLANK COMPLETION STICKER	WAR261	1 ea

Table 1

Removed Parts

U.S. and Canadian Dealers, please follow Warranty Failed Parts Tracking shipping instructions for the disposition of all removed parts. Export distributors, please destroy removed parts unless otherwise advised.

December 2022
SF654A

Labor Allowance

Table 2 - Labor Allowance

Campaign Number	Procedure	Time Allowed (hours)	SRT Code	Corrective Action
SF654A	Remove and replace front radar mounting bracket.	0.6	996-F142A	12-Repair Recall/Campaign

Table 2

IMPORTANT: When the campaign has been completed, locate the base completion label in the appropriate location on the vehicle, and attach the gray completion sticker provided in the field service kit (Form WAR261). If the vehicle does not have a base completion label, clean a spot on the appropriate location of the vehicle and first attach the base completion label (Form WAR259). If a field service kit is not required or there is no completion sticker in the kit, write the campaign number on a blank sticker and attach it to the base completion label.

Claims for Credit

You will be reimbursed for your parts, labor, and handling (landed cost for Export Distributors) by submitting your claim through the Warranty system within 30 days of completing this campaign. Please reference the following information in OWL:

- Claim type is **Field Service Campaign**.
- In the Campaign field, enter the campaign number and appropriate condition code (**SF654-A**).
- In the Primary Failed Part field, enter **25-SF654-000**.
- In the Parts section, enter the appropriate part number(s) as shown in the Replacement Parts Table.
- In the Labor section, enter the appropriate SRT from the Labor Allowance Table. Administrative time will be included automatically as SRT 939-6010A 0.3 hours.
- The VMRS Component Code is **F99-999-005** and the Cause Code is **A1 - Campaign**.
- This Field Service Campaign will **terminate on December 31, 2023**. Dealers will be notified of any changes to the termination date via an Important Campaign Information Letter posted on the DTNA Portal.

IMPORTANT: OWL must be viewed prior to beginning work to ensure the vehicle is involved and the campaign has not previously been completed. Also, check for a completion sticker before beginning work.

All claims must be submitted within 30 days of the repair and within 30 days of the termination date of the campaign. U.S. and Canadian Dealers: All excess inventory to be returned to the PDC following the conclusion of the campaign must be returned in resaleable condition to the Memphis PDC within 90 days from the termination date. Please submit a PAR to request return to the Memphis PDC. (Canadian dealers should return the kits to their facing PDC.) Export Distributors: Excess inventory is not returnable.

For questions, U.S. and Canadian dealers, contact the Warranty Campaigns Department via Web inquiry at DTNA Portal/WSC, or the Customer Assistance Center at (800) 385-4357, if you have any questions or need additional information. Export distributors, submit a Web inquiry or contact your International Service Manager.

December 2022
SF654A

Copy of Notice to Owners

Subject: Western Star Front Radar Mounting Bracket

Daimler Truck North America LLC (DTNA), on behalf of its wholly owned subsidiary, Western Star Trucks Sales Inc., is initiating Field Service Campaign SF654A to modify specific model years 2021-2023 Western Star 47X, 48X, and 49X vehicles manufactured October 9, 2020, through May 2, 2022.

On specific vehicles, the front radar mounting bracket may cause false positive radar readings.

A new radar bracket will be mounted to the front of the bumper.

Please contact an authorized DTNA dealer to arrange to have the campaign performed and to ensure that parts are available at the dealership. The campaign will take approximately one hour and will be performed at no charge to you. To locate an authorized dealer, search online at NorthAmerica.DaimlerTruck.com/contact-us/. Scroll down to "Locate a Dealer," and select the appropriate brand.

This Field Service Campaign will **terminate on December 31, 2023**. Please make sure the campaign is completed prior to this date. Work completed after this date will be done at the customer's expense.

As stated in the terms of your express limited warranty, DTNA will not pay for any damage caused by failure to properly maintain your vehicle. DTNA considers the work necessary under this campaign to be proper maintenance and will, therefore, not pay for any damage to your vehicle caused by your failure to have the repairs that are the subject of this campaign performed in a reasonable time.

Contact the Warranty Campaigns Department at (800) 547-0712, from 7 a.m. to 4 p.m. Pacific Time, Monday through Friday, e-mail address DTNA.Warranty.Campaigns@Daimlertruck.com, or the Customer Assistance Center at (800) 385-4357, if you have any questions or need additional information.

WARRANTY CAMPAIGNS DEPARTMENT

Enclosure

December 2022
SF654A

Work Instructions

Subject: Western Star Front Radar Mounting Bracket

Models Affected: Specific model years 2021-2023 Western Star 47X, 48X, and 49X vehicles manufactured October 9, 2020, through May 2, 2022.

Front Radar Mounting Bracket Replacement

1. Check the base label (Form WAR259) for a completion sticker for SF654 (Form WAR261) indicating this work has been done. The base label is usually located on the passenger door about 12 inches (30 cm) below the door latch. If a sticker is present, no work is needed. If there is no sticker, proceed with the next step.
2. Park the vehicle on a level surface, shut down the engine, and set the parking brake. Chock the tires.
3. Remove the front bumper. For instructions, see **Section 31.02, Subject 100** of the Western Star 47X & 49X workshop manual.
4. Disconnect the batteries.
5. **Figure 1** shows the location of the forward radar. Remove the three fasteners from the radar cover, then remove the cover. See **Fig. 2**.

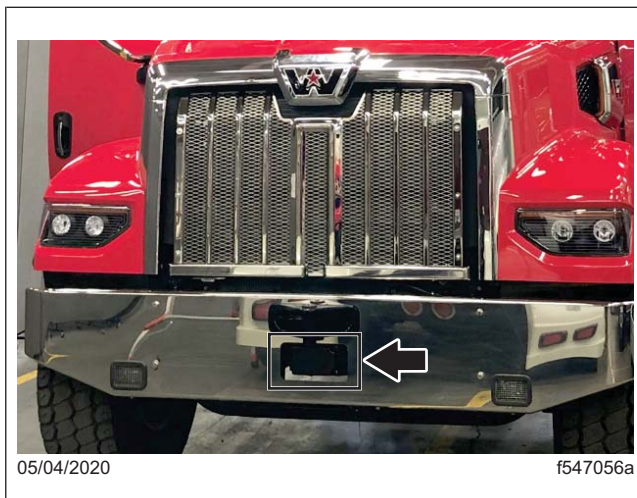

Fig. 1, Forward Radar Location

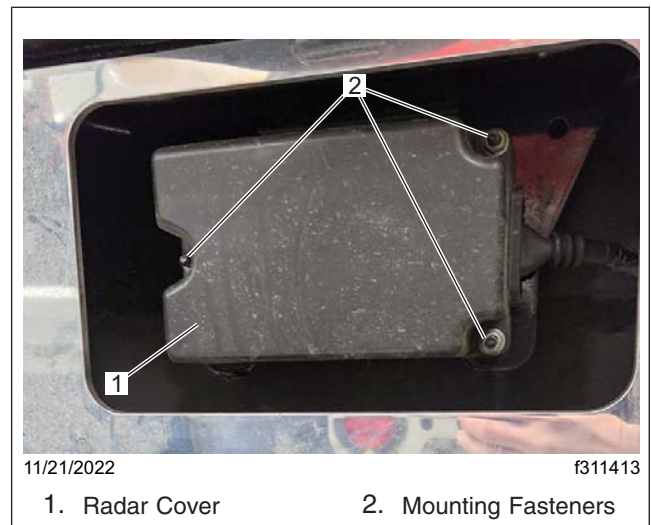

Fig. 2, Radar Cover Removal

December 2022
SF654A

6. Disconnect the electrical connector from the radar unit.
7. While holding each nut on the back side of the bracket with a wrench, remove the three mounting screws that attach the radar to the bracket. See **Fig. 3**.
8. Remove the radar from the vehicle.
9. Remove the two mounting fasteners that attach the radar mounting bracket to the front closing crossmember, then remove the radar mounting bracket. See **Fig. 4**.



Fig. 3, Forward Radar Removal

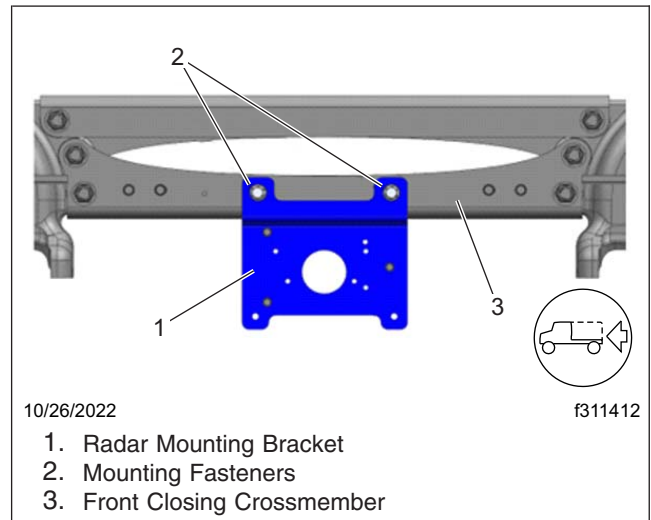

Fig. 4, Radar Mounting Bracket Removal

10. Position the new radar mounting bracket on the front closing crossmember, then install the two mounting fasteners. Tighten the fasteners 35 lbf-ft (47 N-m). See **Fig. 4**.
11. Position the radar unit on the mounting bracket.
12. Install the three radar mounting screws and nuts. Tighten the fasteners 84 lbf-in (949 N-cm).
13. Connect the electrical connector to the radar unit.
14. Position the cover on the radar, and install the fasteners. Tighten the fasteners 48 to 72 lbf-in (542 to 813 N-cm).
15. Connect the batteries.
16. Align the radar. For instructions, see **Section 54.13, Subject 100** of the Western Star 47X & 49X workshop manual.
17. Install the front bumper. For instructions, see **Section 31.02, Subject 100** of the Western Star 47X & 49X workshop manual.
18. Clean a spot on the base label (Form WAR259) and attach a campaign completion sticker for SF654 (Form WAR261), indicating this work has been completed.