

Jumper Harness, Wiper Motor, Install

V-371-004

(December 2022)

Valid for

All Volvo VN/VHD/VAH. INT-Gen2 Trucks 2017 to current

Case description

Certain Volvo VN, VHD, VAH trucks could experience a sporadic wiper motor operation when the wiper switch is in the intermittent position. The wiper motor will operate normally in the low and high mode. To rectify the sporadic operation, a method for installing a jumper harness between the Light Control Module (LCM) and the fuse and relay centre (FRC) has been developed. Follow the instructions below to install the jumper harness.

Parts

| Part Number | Description | Quantity |
|-------------|-------------|----------|
| 24427882 | Harness | 1 |
| 980464 | Tie strap | * |

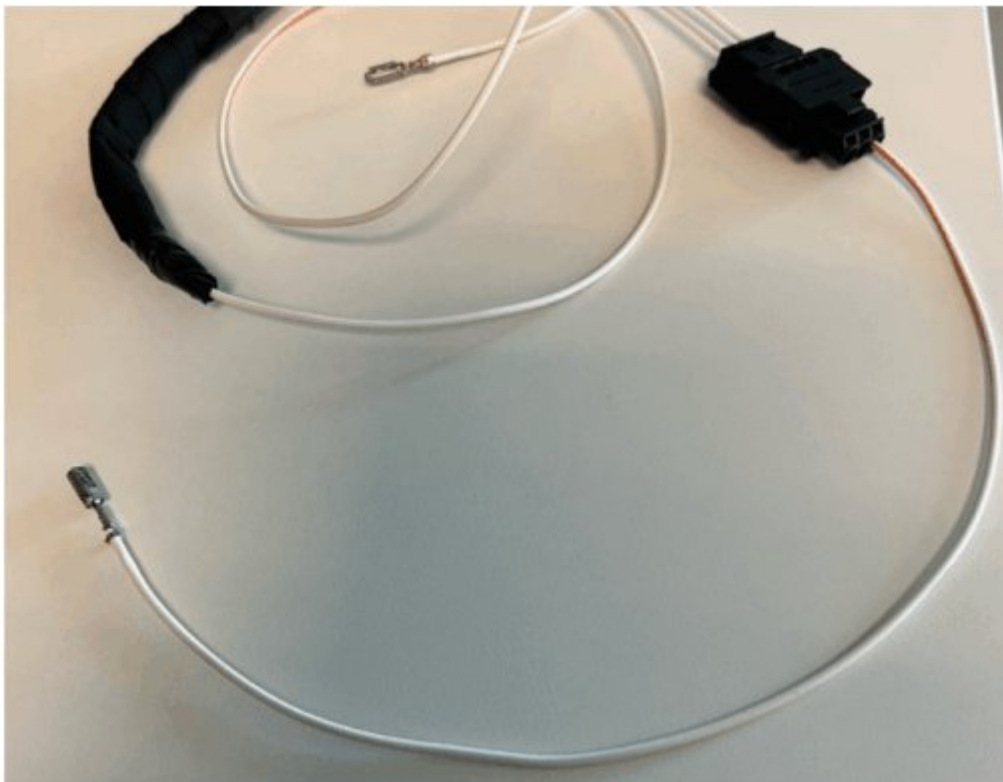

Repair Procedure

1. Park the vehicle on a level surface.
2. Apply the parking brake.
3. Place the gear lever in neutral.
4. Install the wheel chocks.

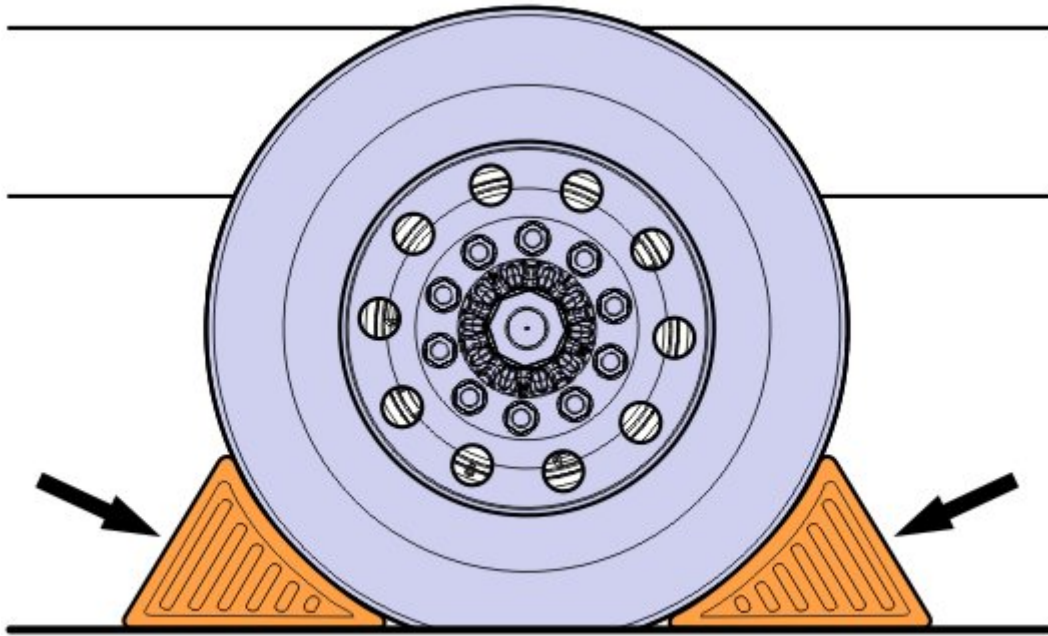

5. Disconnect the cable from the negative battery terminal.

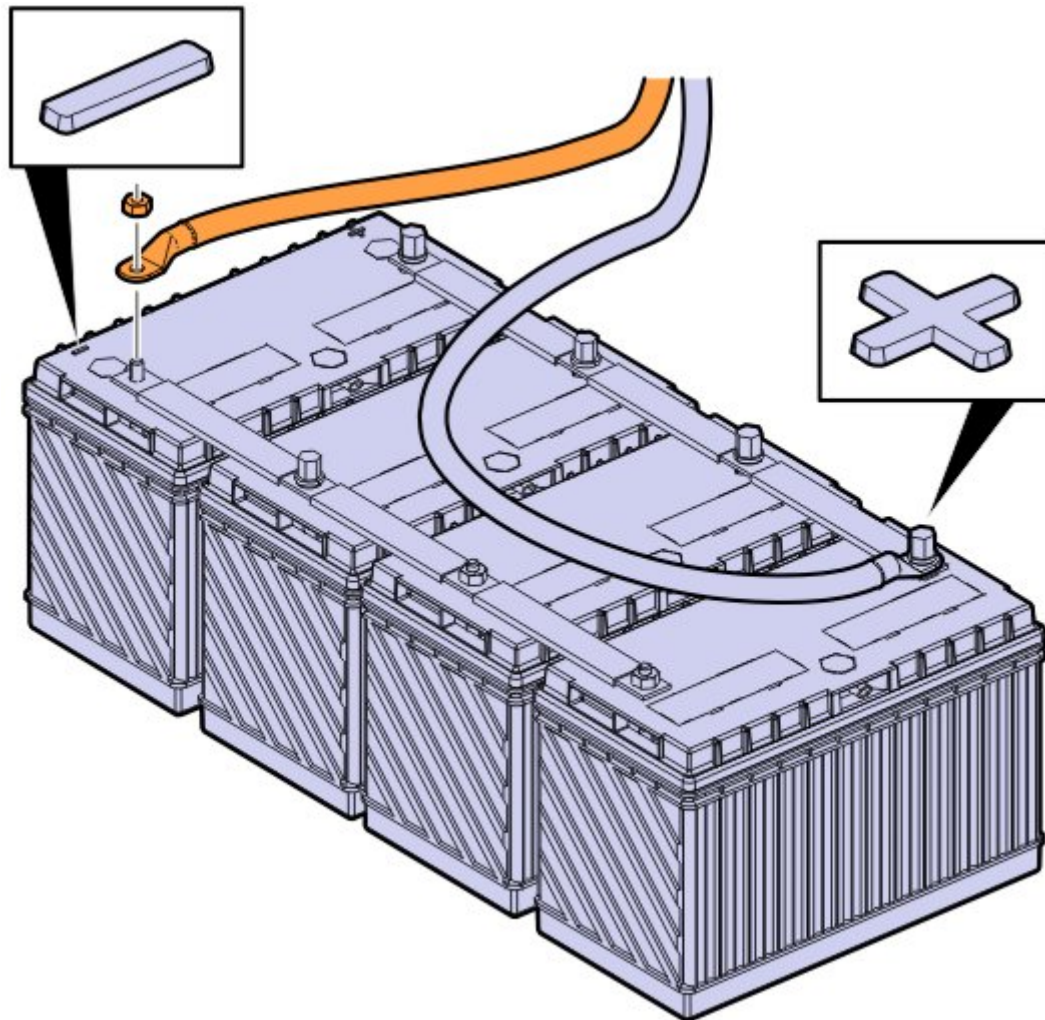

6. Remove the cover panel.

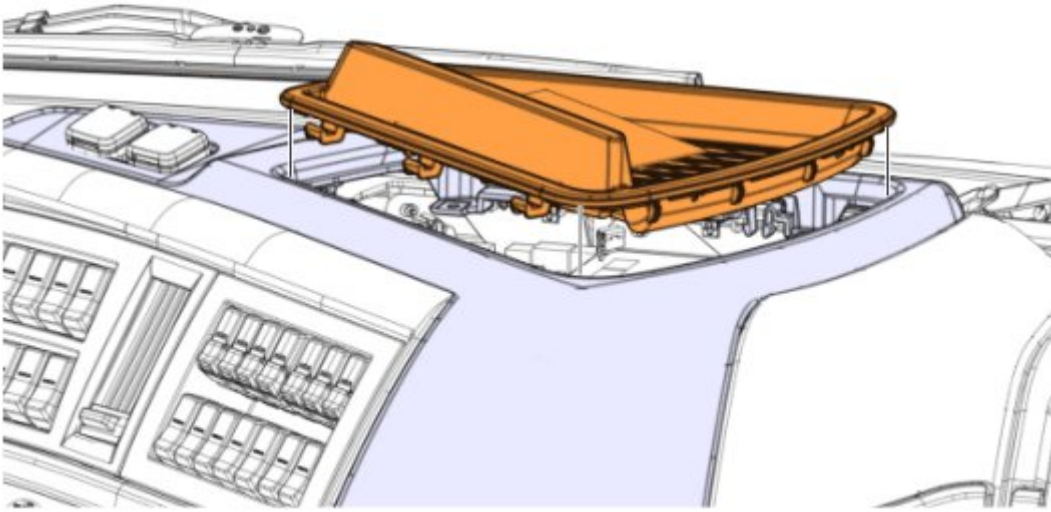

7. Remove the screws.

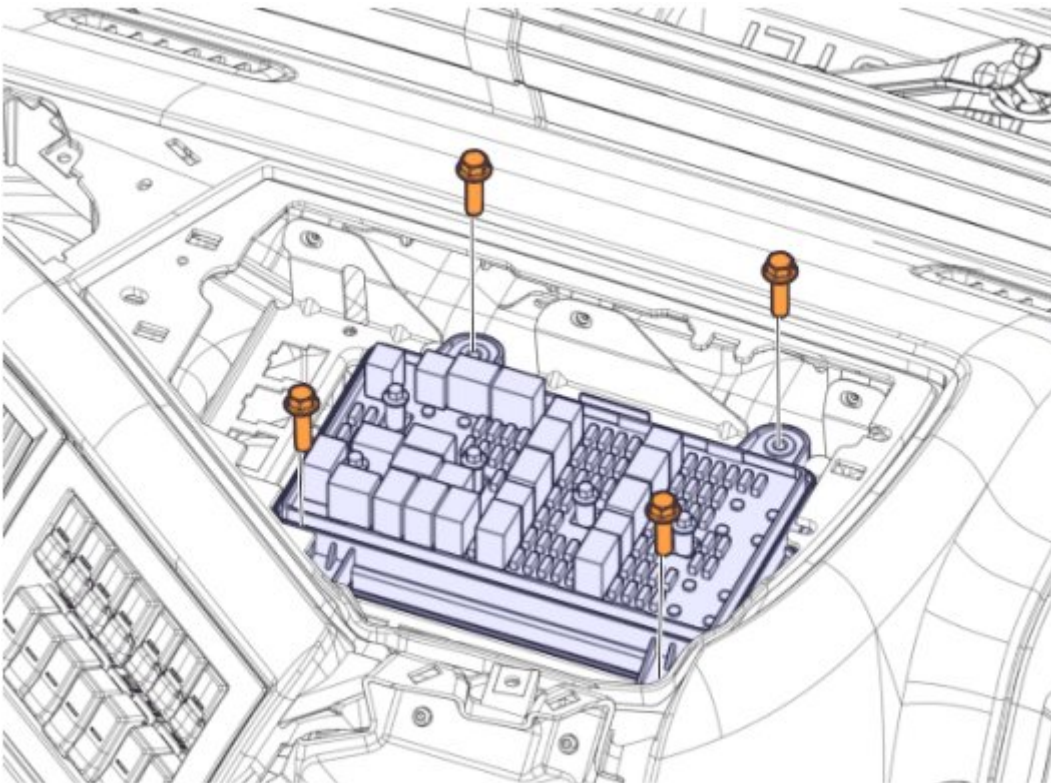

8. Remove the nuts.

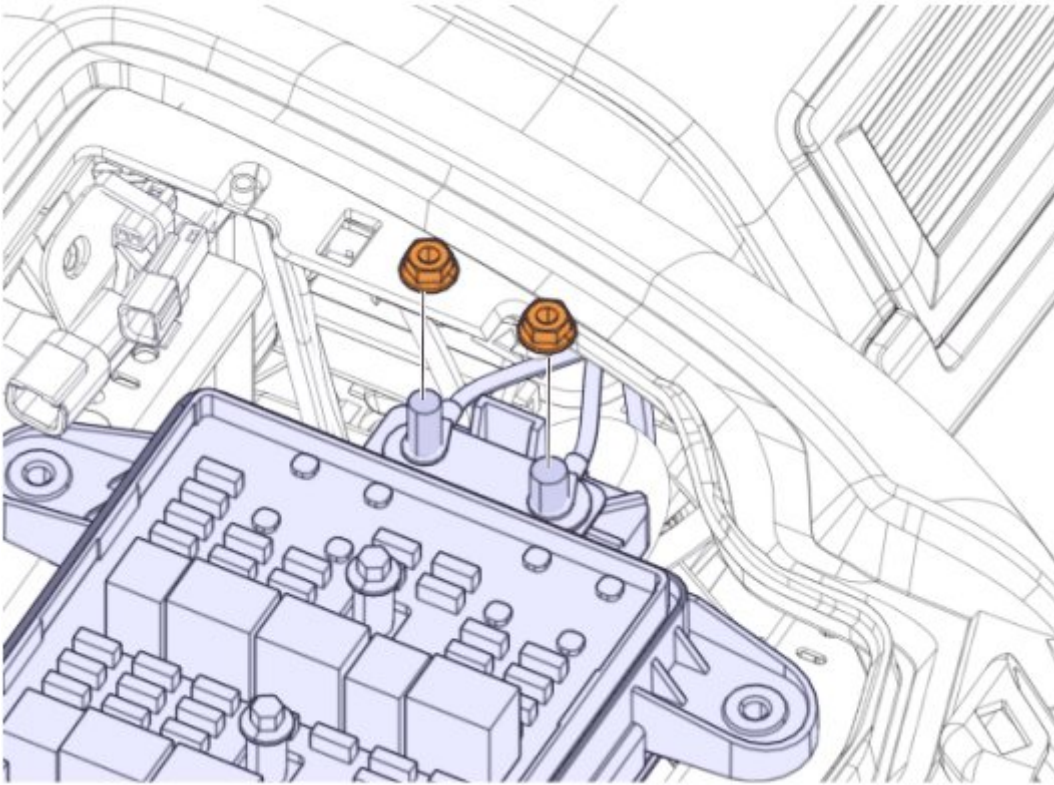

9. Remove the cables.

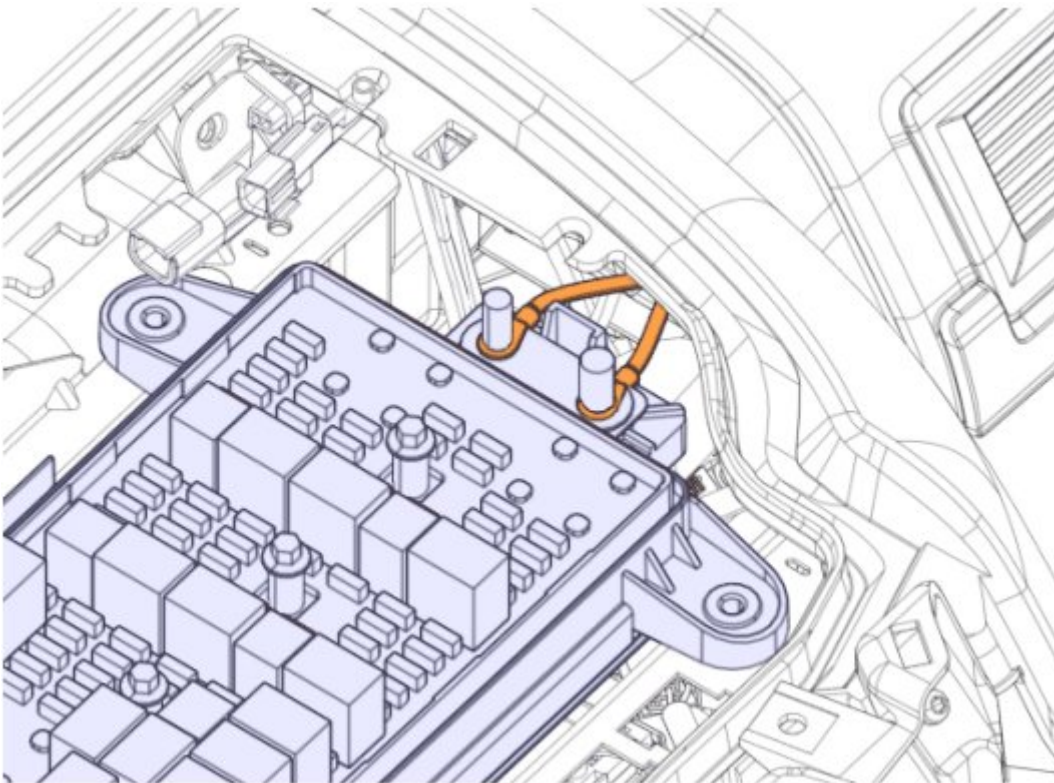

10. Move aside the FRC (fuse and relay centre).

Note: Take care not to damage the panel.

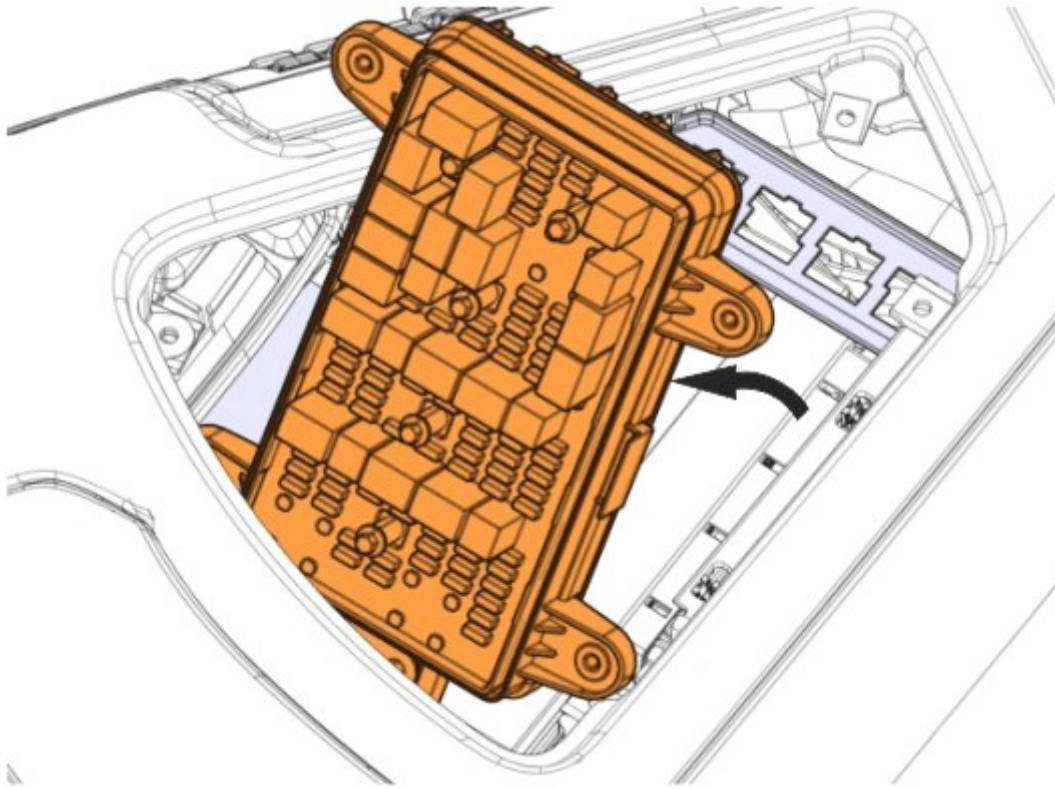

11. Loosen the screw holding FRC_J3 connector into the FRC.

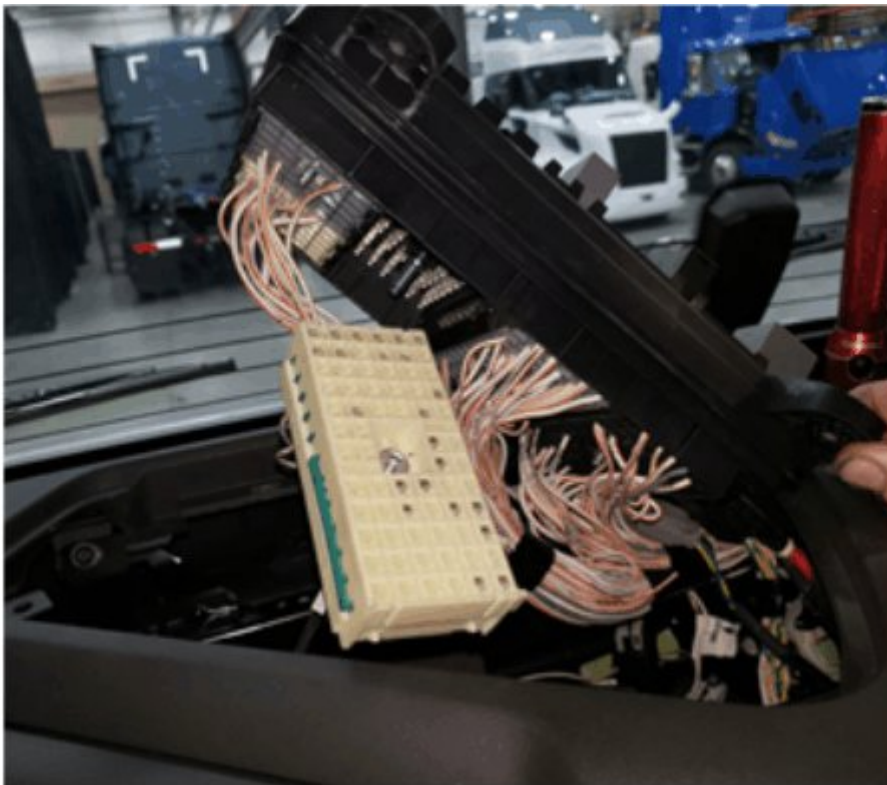

Note: Loosening the screws will push the connectors out of the FRC. Do not use power tools.

12. Pull the J3 connector out to access the pins.

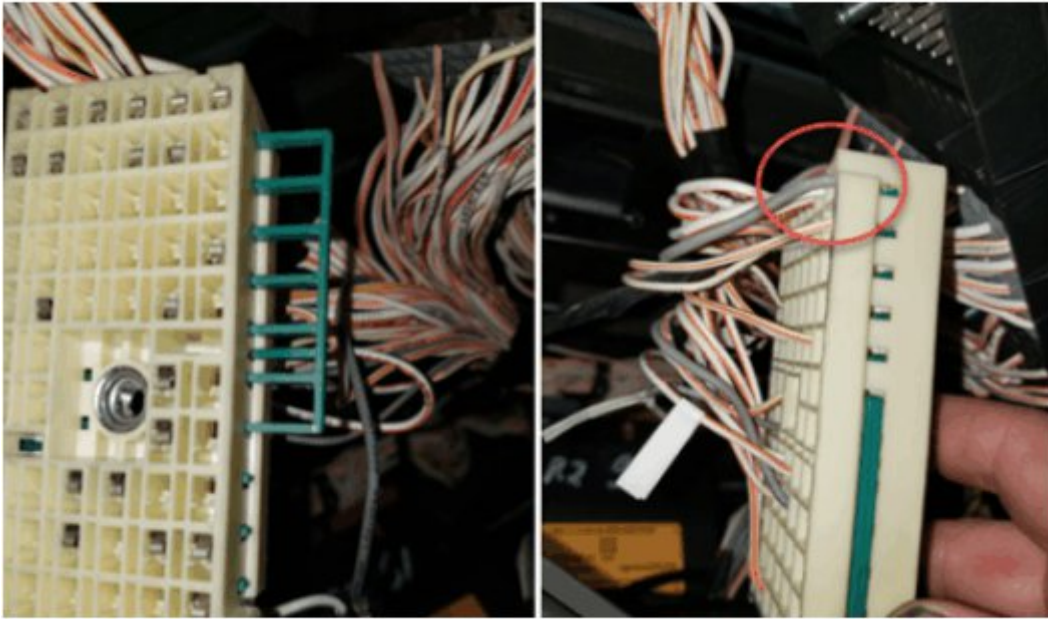

13. Release the locking tab on the J3 connector and de-pin the X03DF5 wire from FRC_J3:A12



14. Insert wire X03DF5 into the 2-pin jumper harness connector Cavity B
15. Insert the wire from the jumper harness 2-pin connector Cavity A into the FRC_J3:A12 connector cavity.
16. Install the connector lock.
17. Install the FRC_J3 connector back into the FRC and torque to spec.

| Tightening torque | |
|-------------------|------------------------------|
| Screw | 3.5 ± 0.5 Nm (31 ± 4 lbf.in) |

18. Remove the A27C connector from the LCM.

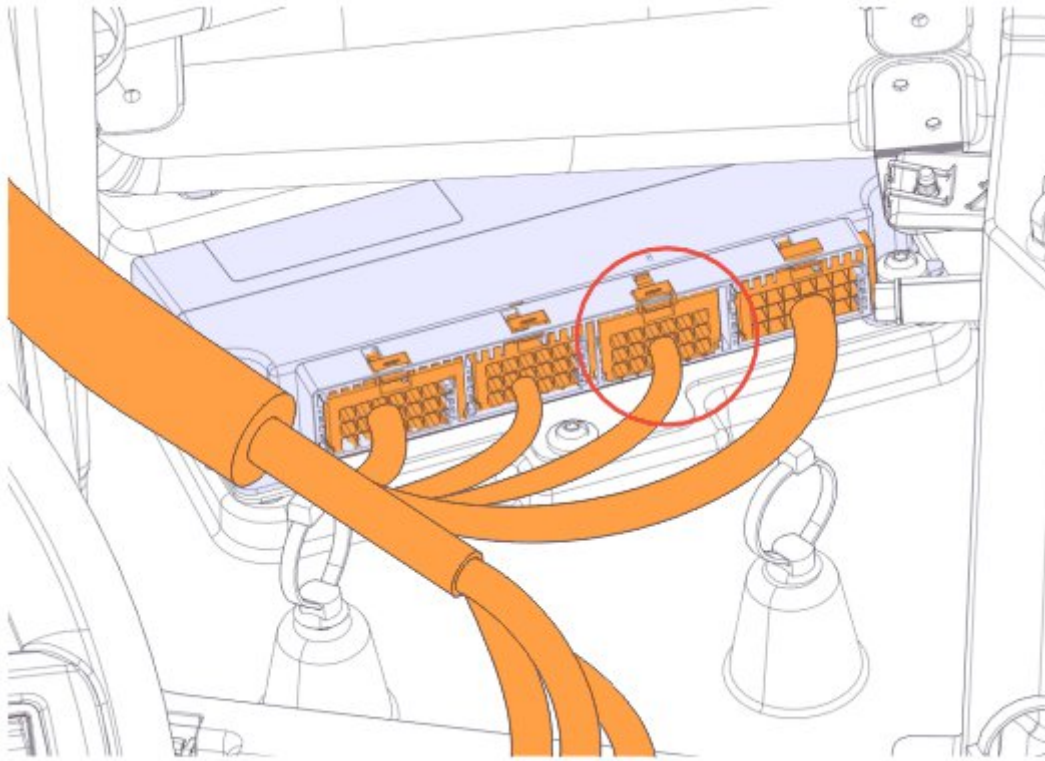

19. Release the locking tab and de-pin wire PC11A6 from A27.C.11



20. Release the locking tab on the new jumper harness.

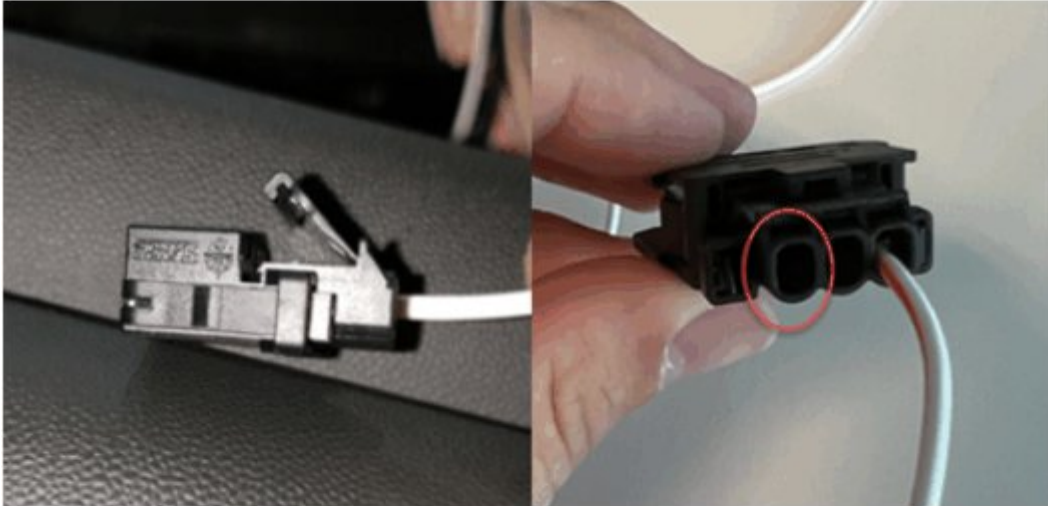

21. Insert wire PC11A6 into the 3-pin jumper harness connector cavity 1.
22. Insert the wire from the 3-pin jumper harness connect cavity 3 into A27.C:11 connector.

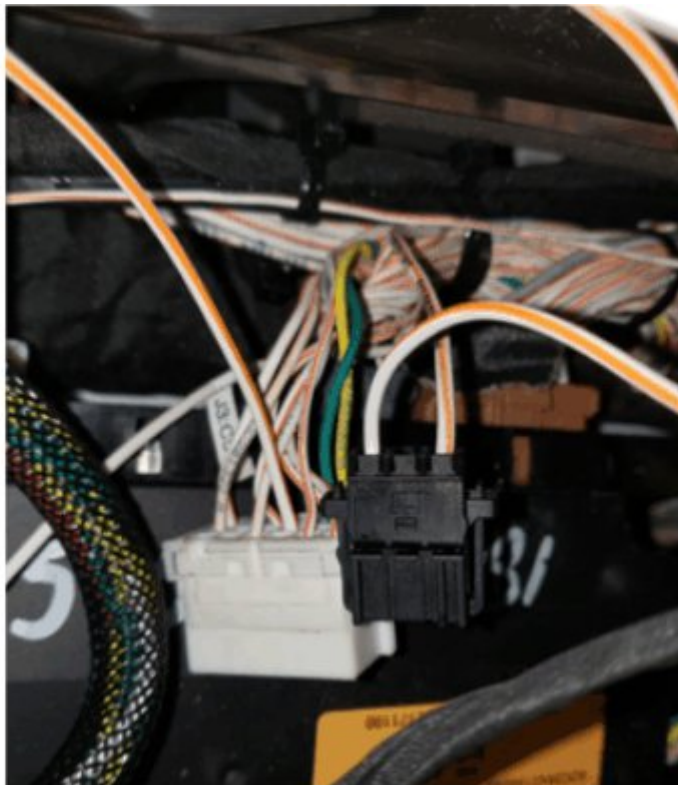

23. Install the A27C connector into the LCM.

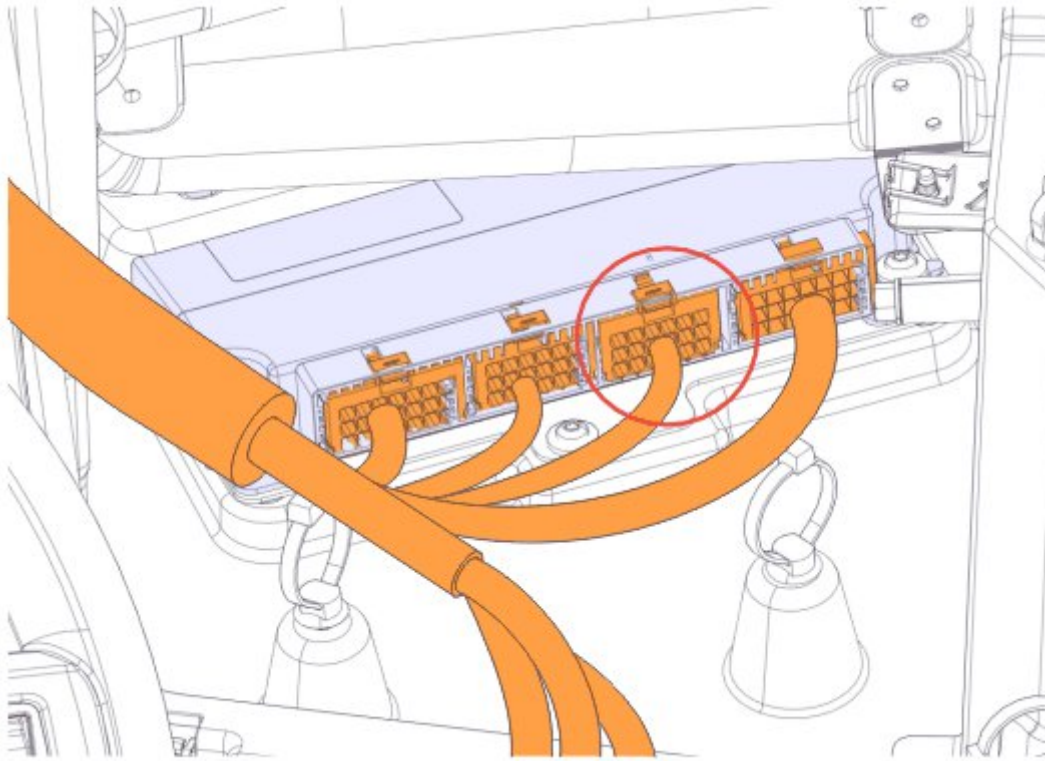

24. Connect the two connectors on the jumper harness together.
25. Secure the jumper harness in the dash.
26. Position the FRC.
27. Install the screws.
28. Torque the screws.

| Tightening torque | |
|--------------------------|------------------------------|
| Screw | 3.1 ± 0.8 Nm (27 ± 7 lbf.in) |

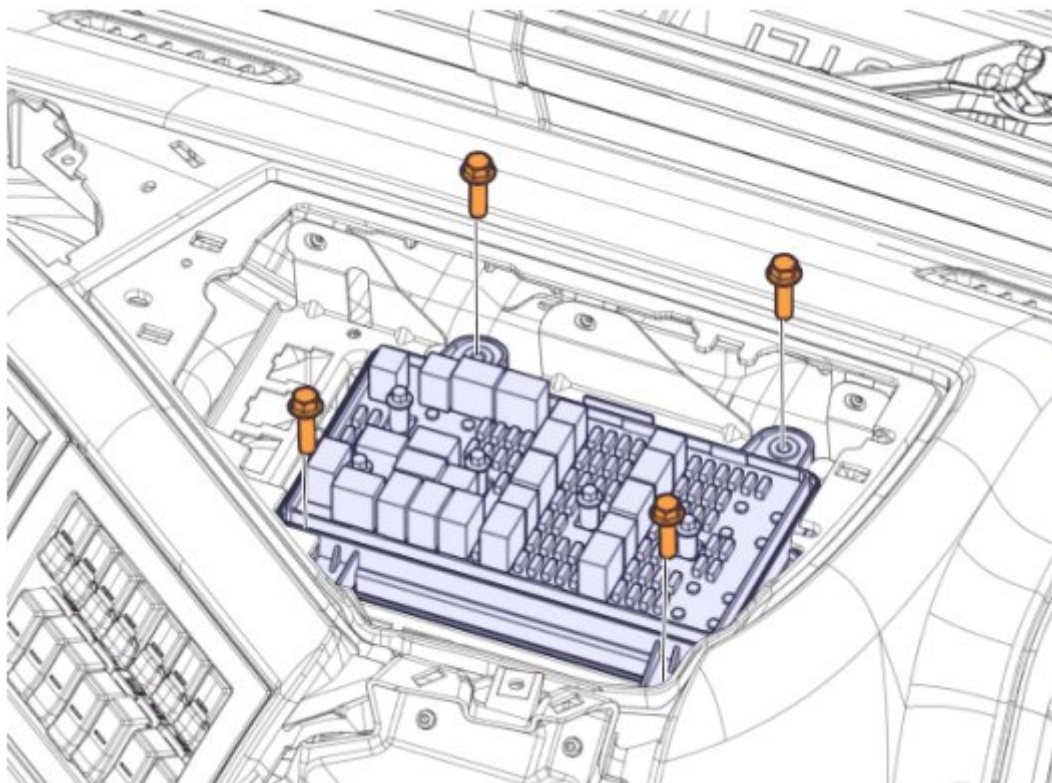

29. Install the cables.

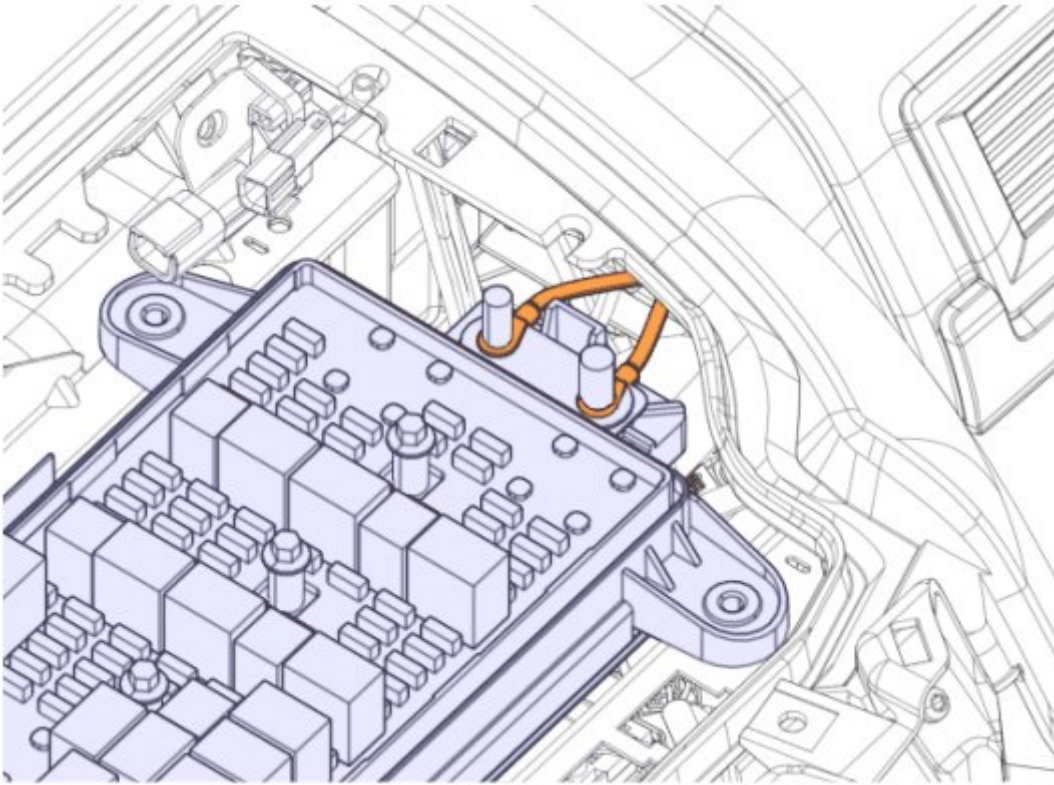

30. Install the nuts.

31. Tighten the nuts to torque.

| Tightening torque | |
|--------------------------|------------------------------------|
| Screw M10 | 18 ± 1 Nm (13 ± 1 lbf.ft) |
| Screw M8 | 16 ± 1 Nm (12 ± 1 lbf.ft) |

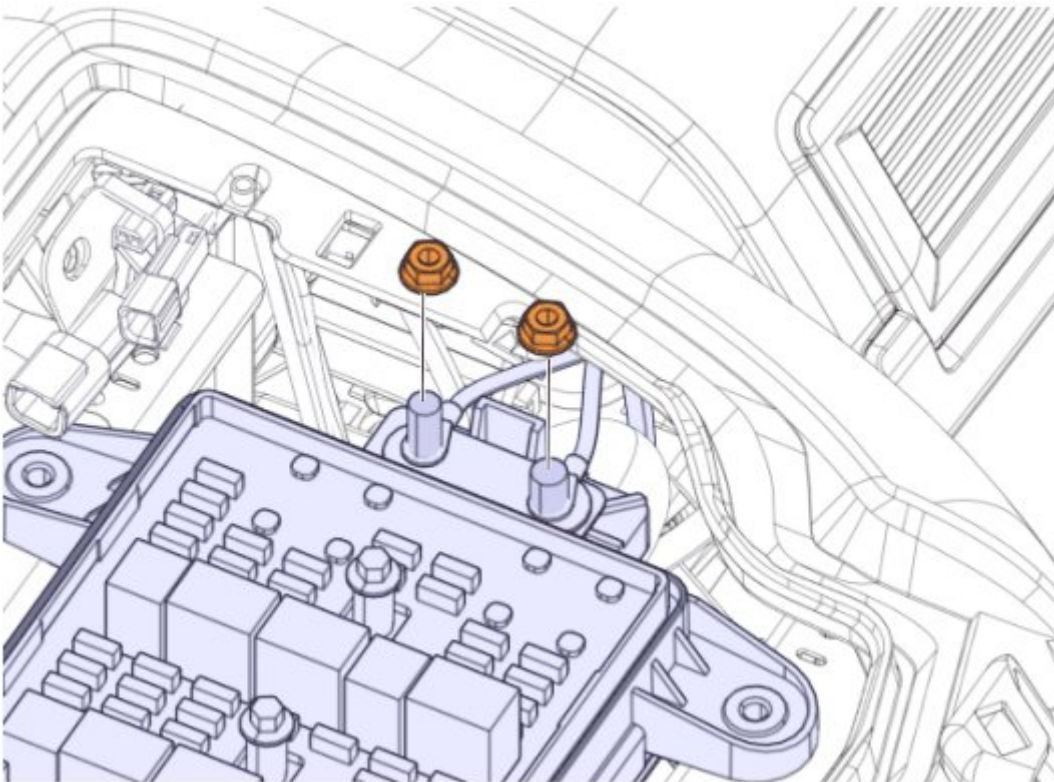

32. Install the cover panel.

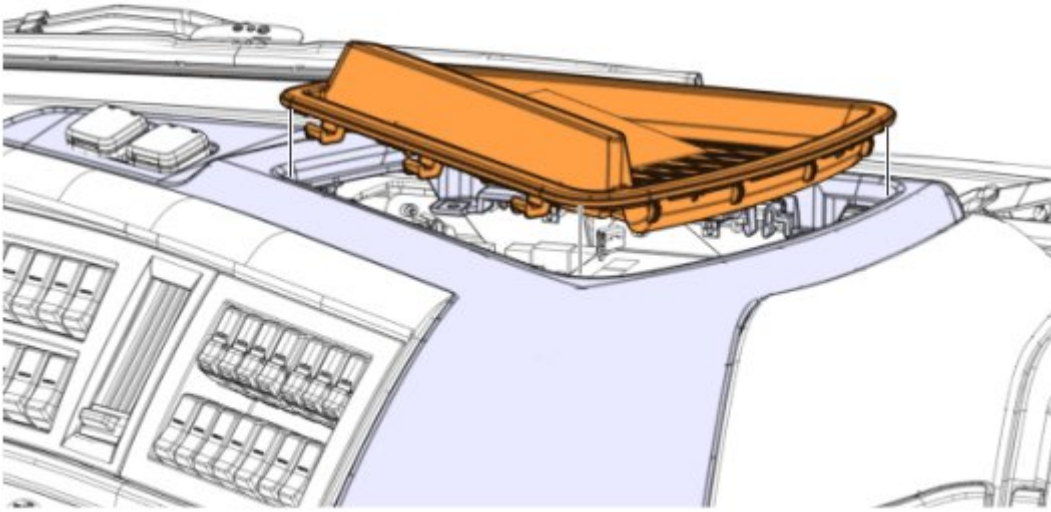

33. Reconnect the negative battery terminal.

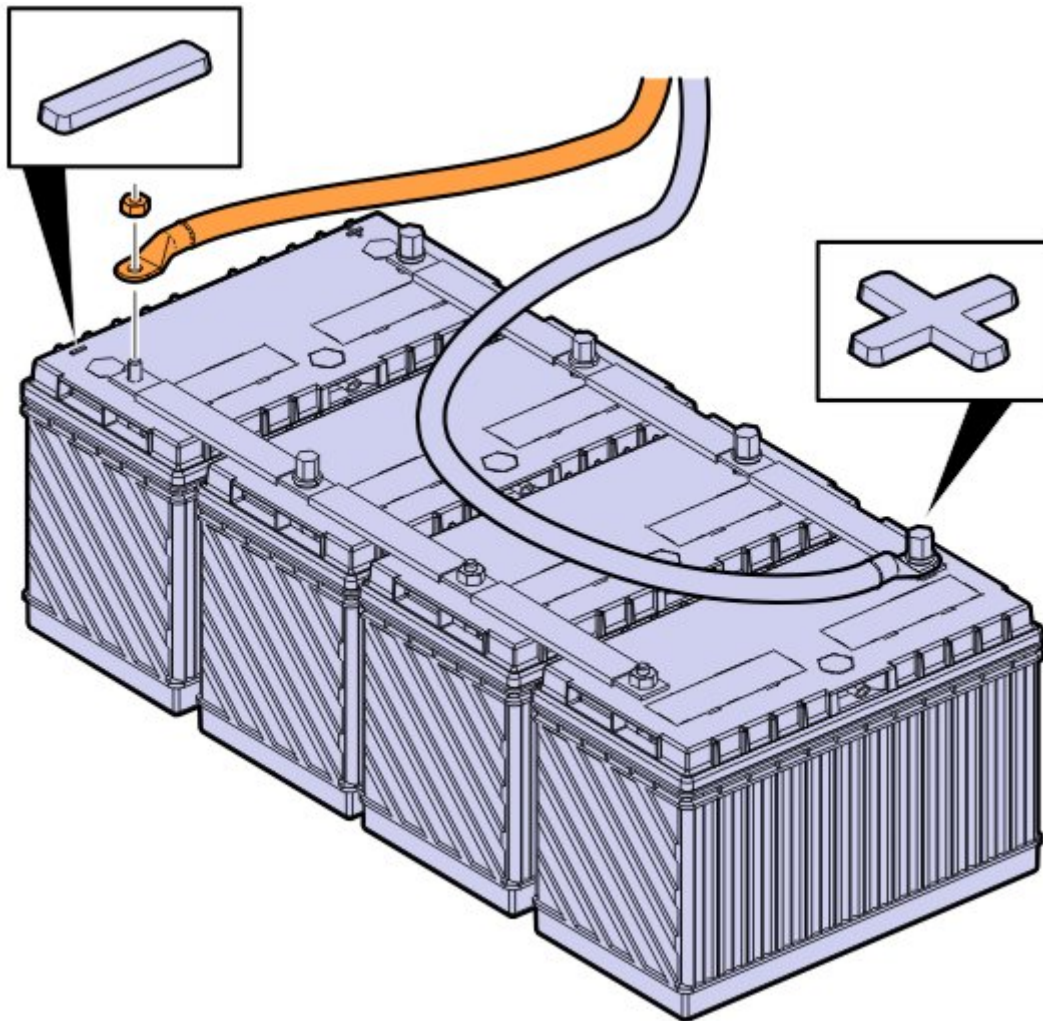

34. Verify the wiper is functioning correctly.
A. Turn on the ignition switch.
B. Turn on the wiper to any speed position.

C. Turn off the Ignition switch while the wipers are in mid position.

D. Verify that the wipers return to the parked position when the ignition switch is turned off.

35. Remove wheel chocks.

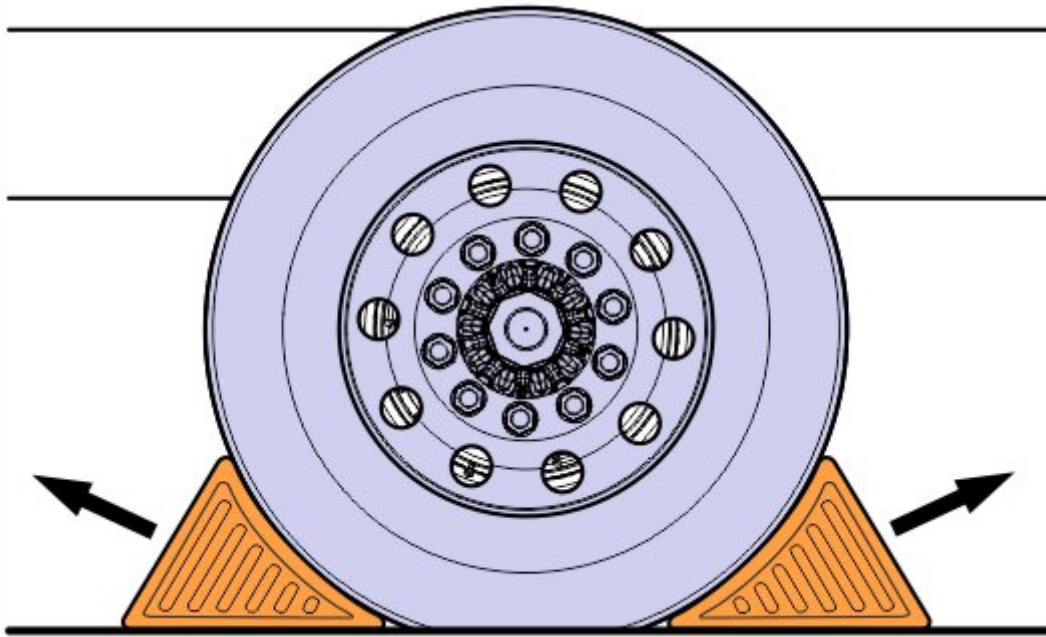

36. Release vehicle to service.

Warranty information

Reimbursement

| | |
|--|-------------------------------|
| This repair may be eligible for reimbursement if a product failure was experienced within time and mileage limits of the applicable Warranty coverage. Reimbursement is obtained via the normal claim handling process. | UCHP Reimbursement |
| Claim Type (used only when uploading from the Dealer Bus. Sys.) | W |
| Labour Code | |
| Jumper harness, wiper motor, install | 3719-02-02-01 — (1 hrs) |

Issued by

Technical Service