



MMD Incorrect Fuel Tank Label

Service Category Service Department

Section Function Group 231

Technician Skill Level C

Market North America

Applicability

Mack

Model Years	Models
2023	MD6, MD7

Introduction

Mack trucks has determined that certain model year 2023 Mack Medium Duty (“MMD”) vehicles, could have been built with fuel tanks that were incorrectly stamped. On affected vehicles the liter and gallon capacities scribed on the tear drop cover are reversed. To correct this defect an inspection of the fuel tank is required and when necessary, a restamp of the correct capacities.

Production Change Information

This bulletin applies to vehicles built within the specified production changes below.

Brand	Engine	Emission Level	Starting Build Date	Ending Build Date
Mack	CU7	EM-USA21	21-July-2022	4-October-2022

Warranty Information

This repair may be eligible for reimbursement if a product failure was experienced with in time and mileage limits of the applicable Warranty coverage. Reimbursement is obtained via the normal claim handling process.		
Claim Type (used only when uploading from the Dealer Bus. Sys.)		B
Main Labor Code	Description	Hours
1720-16-09-01	Campaign, General (0.1 hrs. X 5)	0.5
Causal Part	21075719	
SCC Authorization Code	S7675	
Expiration Date	December 31, 2023	

Parts Information

N/A

Required Tools & Equipment

N/A

Repair Procedure

1. Park the vehicle on a level surface.
2. Apply the parking brake.
3. Place the gear neutral.
4. Install wheel chocks.

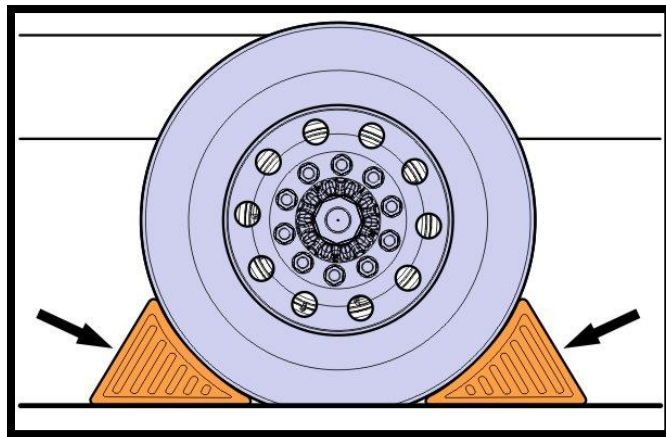

5. Disconnect the cable from the negative terminal.

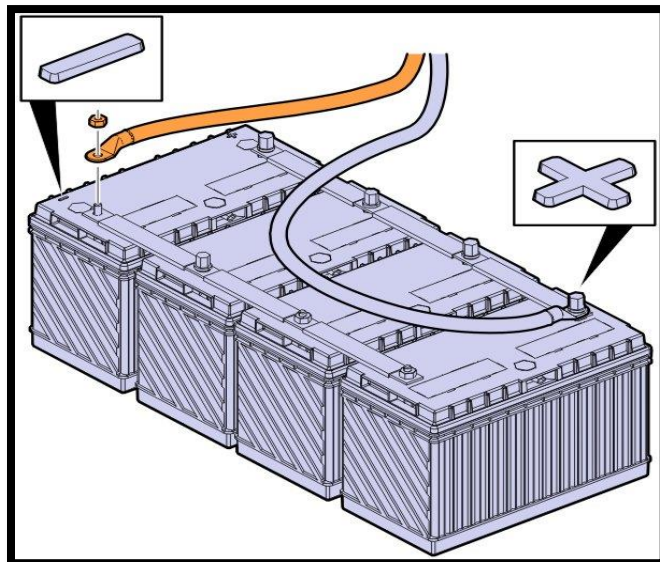

6. Inspect the capacity scribed onto tear drop cover of the fuel tank by comparing it to the permanent adhesive tag. The Adhesive Tag has the correct capacity listed in Gallons.

NOTE: You will have to convert the gallons to liters.

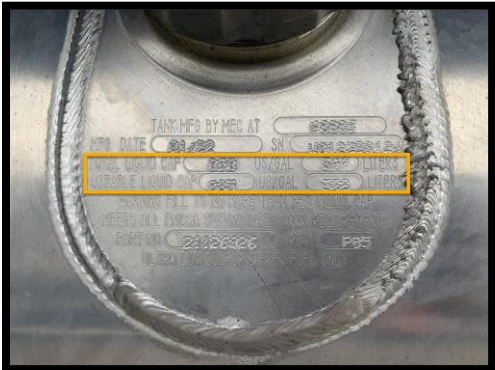

- 7. If the gallons & liters are found incorrect, remove the scribed numbers using a suitable abrasive and stamp the correct capacities.



- 8. Connect the cable to the negative terminal.

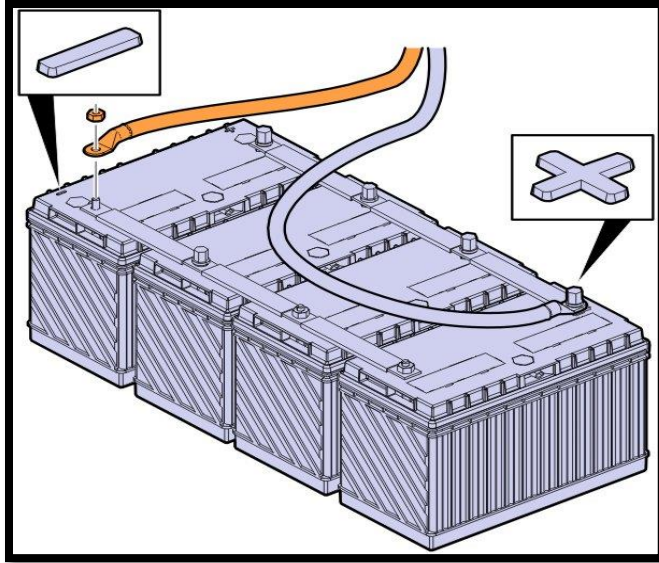

9. Remove the wheel chocks.

