



NUMBER: 05-003-22

GROUP: 05 - Brakes

DATE: April 5, 2022

This bulletin is supplied as technical information only and is not an authorization for repair. No part of this publication may be reproduced, stored in a retrieval system, or transmitted, in any form or by any means, electronic, mechanical, photocopying, or otherwise, without written permission of FCA US LLC.

This Technical Service Bulletin (TSB) has also been released as a Rapid Service Update (RSU) 22-069, date of issue April 5, 2022. All applicable Un-Sold RSU VINs have been loaded. To verify this RSU service action is applicable to the vehicle, use VIP or perform a VIN search in DealerCONNECT/Service Library. All repairs are reimbursable within the provisions of warranty. This RSU will expire 18 months after the date of issue.

SUBJECT:

Brake Lines Over-Torqued

OVERVIEW:

This bulletin involves inspecting and possibly replacing the front brake lines from the Brake System Control Module (BSCM) to both the front brake hose junctions.

MODELS:

2022 (WL) Jeep Grand Cherokee

NOTE: This bulletin applies to vehicles within the following markets/countries: North America, EMEA, APAC and LATAM.

NOTE: This bulletin applies to unsold vehicles built on or after October 03, 2021 (MDH 1003XX) and built on or before January 21, 2022 (MDH 0121XX).

SYMPTOM/CONDITION:

Customers may experience the following:

- Brake fluid leak. This minor leak is coming from the front brake line unions.

DIAGNOSIS:

Using a Scan Tool (wiTECH) with the appropriate Diagnostic Procedures available in DealerCONNECT/Service Library, verify all related systems are functioning as designed. If DTCs or symptom conditions, other than the ones listed above are present, record the issues on the repair order and repair as necessary before proceeding further with this bulletin.

If a VIN is listed in VIP or your RSU VIN list, perform the Repair Procedure. **This RSU only applies to vehicles on the RSU VIN list.**

PARTS REQUIRED:

Qty.	Part No.	Description
1 (AR)	68423962AB	IBC to Left Front Junction
1 (AR)	68423961AB	IBC to Right Front Junction
1 (AR)	06508531AA	Intermediate shaft bolt
(AR)	04318080AD	Mopar® DOT 3 Brake Fluid, SAE J1703

REPAIR PROCEDURE:

1. Remove the Cowl Panel Cover. Refer to the detailed service procedures available in DealerCONNECT/Service Library under: Service Info>23 - Body / Exterior / Cover, Cowl Panel / Removal and Installation.
2. Are the front brake line unions leaking?
 - YES>>> Proceed to [Step 3](#).
 - NO>>>This bulletin has been completed, use inspect LOP (05-30-77-90) to close the active RSU.
3. Remove the intermediate shaft at the steering column. Refer to the detailed service procedures available in DealerCONNECT/Service Library under: Service Info>19 - Steering / Column / shaft, Intermediate / Removal and Installation.

NOTE: Remove and DISCARD the intermediate shaft pinch bolt. Torque NEW fastener to 45 N·m (33 Ft. Lbs.)

4. Remove the Cowl Extension Silencer. Refer to the detailed service procedures available in DealerCONNECT/Service Library under: Service Info>23 - Body / Exterior / Silencer, Cowl Extension / Removal and Installation.
5. Place vehicle on hoist. Refer to the detailed service procedures available in DealerCONNECT/Service Library under: Service Info>04 - Vehicle Quick Reference/Hoisting/Standard Procedure.
6. Remove Front Wheels. Refer to the detailed service procedures available in DealerCONNECT/Service Library under: Service Info>22 - Tires and Wheels/Removal and Installation.
7. Reposition front wheel liners.
8. Unthread brake line fittings and release retainer from the brake flex hose on the left side ([Fig. 1](#)).

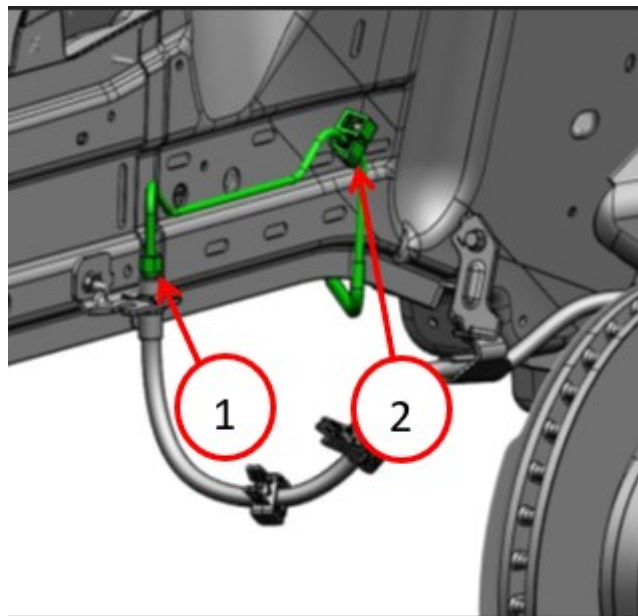

Fig. 1

Left Brake Line At Wheel

- 1 - Brake Line Fitting
2 - Brake line Retainer

9. Unthread brake line fittings and release retainer from the brake flex hose on the right side (Fig. 2) .

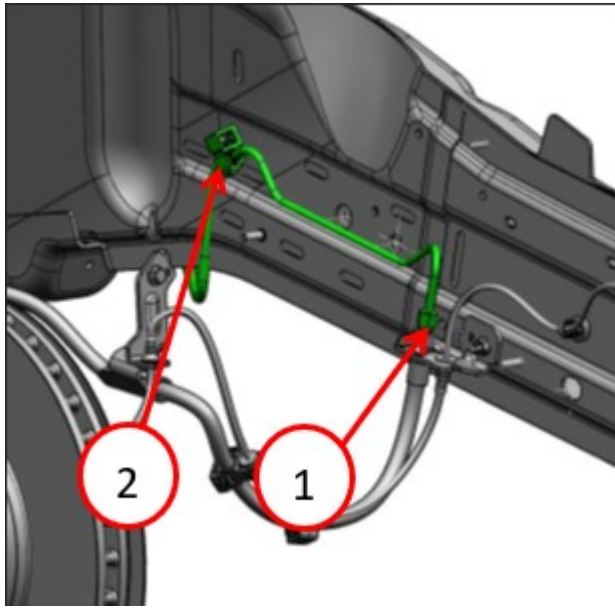

Fig. 2
Right Brake Line At Wheel

- 1 - Brake Line Fitting
2 - Brake line Retainer
-

10. Unthread the left front brake line fittings and release retainers from the left brake line at BSCM (Fig. 3)

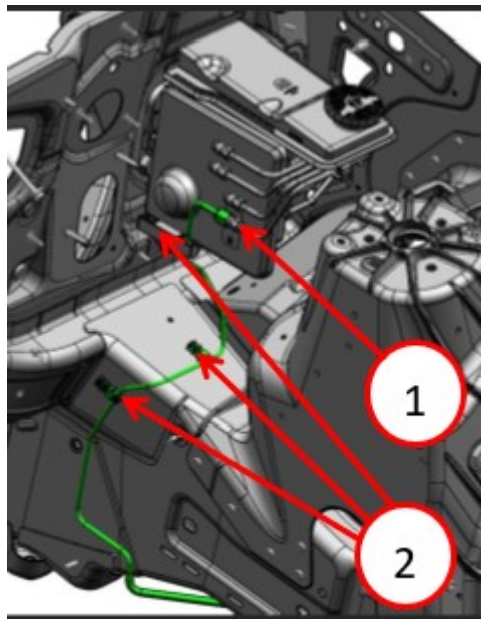

Fig. 3
Left Brake Line And Retainers At BSCM

- 1 - Brake Line Fitting
2 - Brake line Retainers
-

11. Unthread the right front brake line fittings and release retainers from the right brake line at BSCM (Fig. 4) .

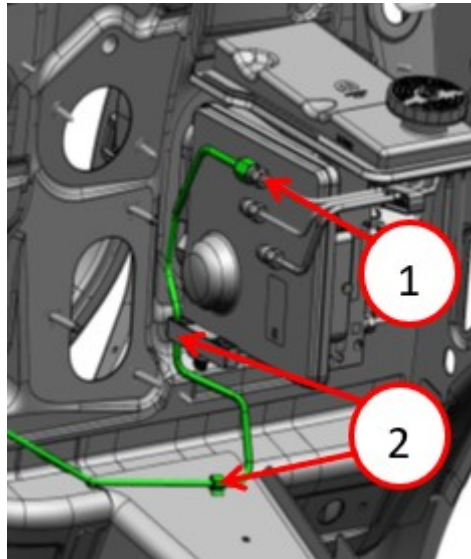

Fig. 4
Right Brake Lines At BSCM

- 1 - Brake Line Fitting
2 - Brake line Retainers

12. Trace brake line retainers along dash panel and separate the brake lines from their retainers (Fig. 5) .

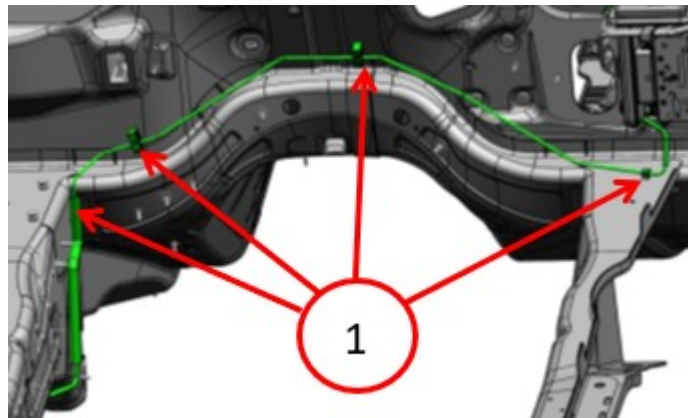

Fig. 5
Retainers On Dash Panel

- 1 - Brake line Retainers

13. Carefully remove the brake lines from vehicle.
14. Install the new lines ensuring to mate and secure them in their retainers.
15. Thread the brake line fittings in at the BSCM.
16. Install the Cowl Extension Silencer. Refer to the detailed service procedures available in DealerCONNECT/Service Library under: Service Info>23 - Body / Exterior / Silencer, Cowl Extension / Removal and Installation
17. Reinstall intermediate steering shaft at steering column. Refer to the detailed service procedures available in DealerCONNECT/Service Library under: Service Info>19 - Steering / Column / shaft, Intermediate / Removal and Installation.

NOTE: Remove and DISCARD the intermediate shaft pinch bolt. Torque NEW fastener to 45 N·m (33 Ft. Lbs.)

18. Install the Cowl Panel Cover. Refer to the detailed service procedures available in DealerCONNECT/Service Library under: Service Info>23 - Body / Exterior / Cover, Cowl Panel / Removal and Installation.
19. Thread the brake line fittings into the rubber brake flex hoses on both sides.
20. Reinstall repositioned wheel liners.
21. Using the scan tool, and a pressure bleeding tool, perform the brake fluid bleed routine. Refer to the detailed service procedures available in DealerCONNECT/Service Library under: Service Info>05 - Brakes, Base/Standard Procedure.
22. Install Front wheels. Refer to the detailed service procedures available in DealerCONNECT/Service Library under: Service Info>22 - Tires and Wheels/Removal and Installation.
23. Check for leaks.
24. Test drive for proper brake pedal feel.

POLICY:

Reimbursable within the provisions of the warranty.

TIME ALLOWANCE:

Labor Operation No:	Description	Skill Category	Amount
05-30-77-90	Front brake lines - Inspect (2 - Skilled)	5 - Brakes	0.3 Hrs.
05-30-77-91	Front brake line - Inspect and Replace (Left Line) (2 - Skilled)	5 - Brakes	2.9 Hrs.
05-30-77-92	Front brake line - Inspect and Replace (Right Line) (2 - Skilled)	5 - Brakes	3.0 Hrs.
05-30-77-93	Front brake lines - Inspect and Replace (Both Right and Left lines) (2 - Skilled)	5 - Brakes	3.5 Hrs.

FAILURE CODE:

ZZ	Service Action
----	----------------