



Bulletin No.: PIT5958
Published date: 11/17/2022

Preliminary Information

PIT5958 Loose / Side To Side Movement At The 2nd Row Bucket Seat And/Or Pop Clunk Click Noise

Models

Brand:	Model:	Model Years:	VIN:		Engine:	Transmissions:
			from	to		
Cadillac	Escalade Models	2021 - 2023	All	All	All	All
Chevrolet	Suburban	2021 - 2023	All	All	All	All
Chevrolet	Tahoe	2021 - 2023	All	All	All	All
GMC	Yukon Models	2021 - 2023	All	All	All	All

Involved Region or Country	North America
Additional Options (RPO)	2nd Row Bucket Seats
Condition	Some customers may comment that either the left and/or right 2nd row bucket seat has side to side movement or feels loose. In some cases, a pop/clunk/click type noise may be heard from the seat movement.
Cause	The cause of this concern could be excessive clearance between the seat riser link and seat cushion frame, as shown below.

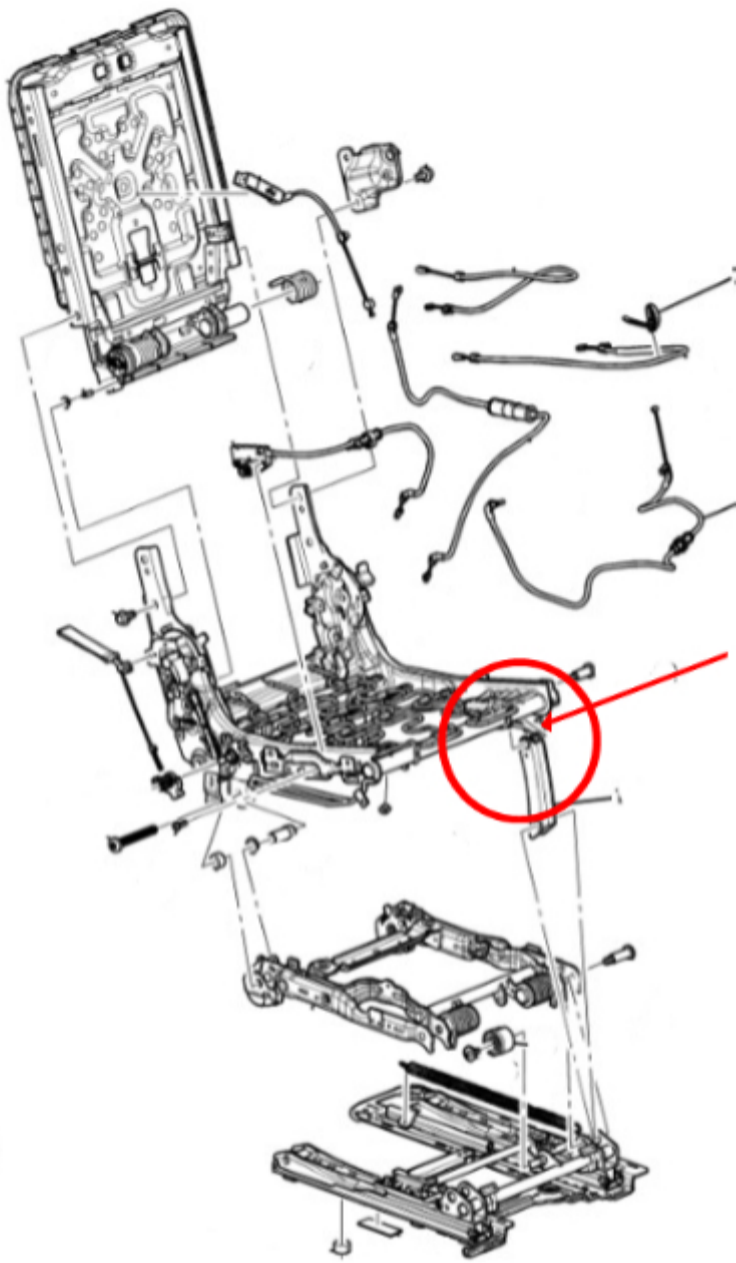

FRT

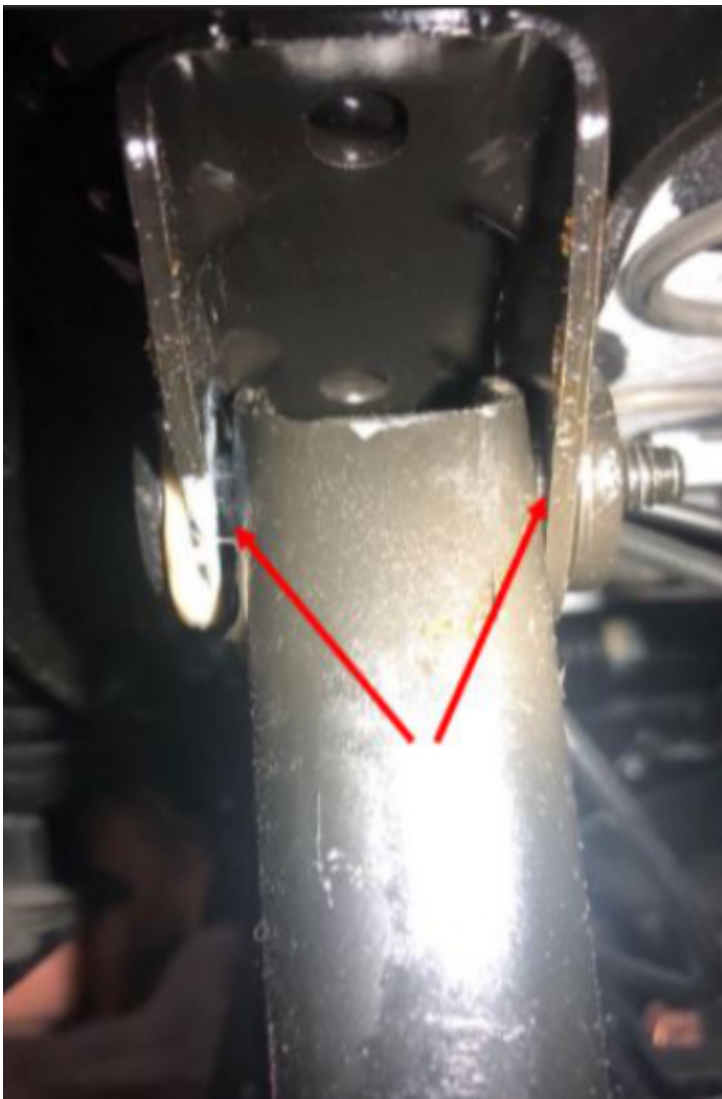

Correction:

If it is found that the concern is caused by excessive clearance between the seat riser link and seat cushion frame, as shown above, then GM Engineering is working on a fix. At this time, do not replace any parts.

Note: This concern is not a safety issue.

Additional SI Keywords

play pivot lateral

Version History

Version	1
Modified	11/17/2022 - Created on.



GENERAL MOTORS

© 2022 General Motors. All Rights Reserved.