



FIELD SERVICE CAMPAIGN – 22120

10 November 2022

SUBJECT:

Manual Service Disconnect (MSD) Label Replacement

MODELS INVOLVED:

IC Bus® Electric CE and International® eMV™ Series vehicles

DEFECT DESCRIPTION:

Certain IC Bus® Electric CE and International® eMV™ Series vehicles may have been built with incorrect MSD removal instruction labels.

ELIGIBILITY:

This procedure applies ONLY to vehicles marked in the International® Service PortalSM with FSC 22120. Also complete any other open campaigns listed on the Service Portal at this time.

TOOLS REQUIRED:

No special tools required.

PARTS REQUIRED:

NOTE: Vehicles with 3 string require four labels.

Part Number	Description	Quantity
2524288C1	Label, Plug, MSD	2

Table 1 Parts Information

WORK INSTRUCTIONS

WARNING! To prevent personal injury and / or death, or damage to property, park vehicle on hard flat surface, turn the engine off, set the parking brake, and install wheel chocks to prevent the vehicle from moving in both directions.

WARNING! To prevent personal injury and / or death, always wear safe eye protection when performing vehicle maintenance.

WARNING! To prevent personal injury and / or death, or damage to property, keep flames or sparks away from vehicle and do not smoke while servicing the vehicle's batteries. Batteries expel explosive gases.

WARNING! To prevent personal injury and / or death, NEVER service a high-voltage vehicle without completing high-voltage safety training. Before working on vehicle, read and obey all High-Voltage Safety and Lock-Out Tag-Out procedures and information.

WARNING! To prevent personal injury and / or death, wear and use approved high-voltage Personal Protective Equipment (PPE) when near a high-voltage electric vehicle. Inspect PPE before use. Do not use gloves or other PPE with expired dates, holes, cracks, or damage. NEVER touch energized orange high-voltage cables or high-voltage components without wearing approved high-voltage PPE.

WARNING! To prevent personal injury and / or death, read all information in the Safety Information and High-Voltage Safety sections of the service manual.

WARNING! To prevent personal injury and / or death, or damage to property, remove the ground cable from the negative terminal of the battery box before disconnecting any electrical components. Always connect the ground cable last.

WARNING! To prevent personal injury and / or death, or damage to property, if the vehicle must be raised, do not work under the vehicle supported only by jacks. Jacks can slip or fall over.

1. Park vehicle on a level surface.
2. Shift transmission into Park or Neutral and set parking brake.
3. Turn ignition to Key OFF position.
4. Install wheel chocks.
5. Perform Level 1 Manual Service Disconnects (MSD). Refer to appropriate service information for detailed instructions.
6. Obtain access to Level 2 MSDs. Refer to appropriate service information for detailed instructions.

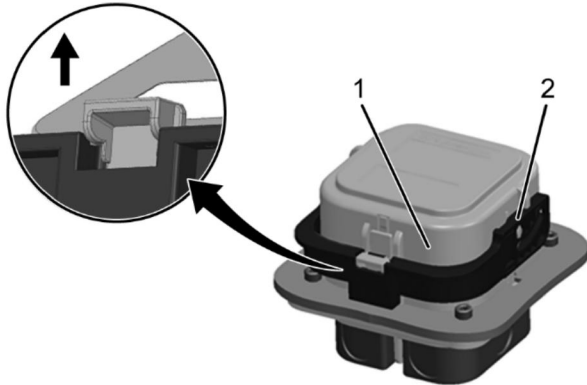

0000475995

Figure 1. MSD Locking Tab

1. Locking tab 1
2. Latch

NOTE: Refer to Steps 7-10 for detailed instructions on removing MSD.

7. Pull up locking tab (Figure 1, Item 1).
8. Simultaneously press on locking tab (Figure 1, Item 1) and lift latch (Figure 1, Item 2) up to a 60 degree position.

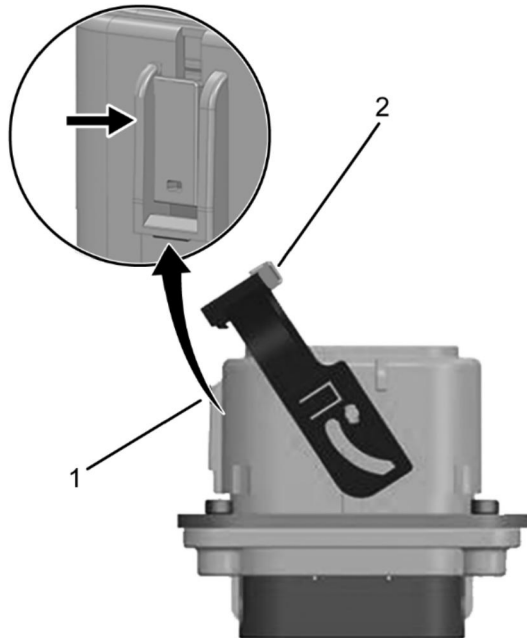

0000475996

Figure 2. MSD Locking Tab

1. Locking tab 2
2. Latch

9. Press locking tab 2 (Figure 2, Item 1) and lift latch (Figure 2, Item 2) to a 90 degree position. Remove MSD.
10. Repeat Steps 7 through 10 for removing additional Level 2 MSD.

WARNING! To prevent personal injury and / or death, or damage to property, do not smoke and keep isopropyl alcohol away from flames and sparks.

WARNING! To prevent personal injury and / or death, or damage to property, do not let isopropyl alcohol stay on your skin. Clean skin and nails using hand cleaner and wash with soap and water. Wash or discard clothing and rags contaminated with isopropyl alcohol.



0000475997

Figure 3. Old MSD Instructions

1. Old label

11. Remove old label (Figure 4, Item 1).
12. Using a clean cloth and 50 / 50 mixture isopropyl alcohol / acetone, remove glue residue and / or any other contaminants from surface area.
13. Allow surface area to dry.
14. Install new MSD instruction label.
15. Apply uniform 20 psi (138 kPa) pressure over high-voltage warning labels to wet out adhesive.
16. Repeat Step 12 through 16 for removing and installing MSD instructions label for the second level MSD.
17. If vehicle is equipped with 3 string option (Figure 2, Item 1), repeat Steps 7 through 16 for removing and installing MSD instructions label.
18. Connect Level 2 MSDs.

- 19. Connect Level 1 MSDs.
- 20. Turn ON high-voltage disconnect switch and 12V disconnect switch.
- 21. Remove wheel chocks.

LABOR INFORMATION

Operation number must appear on all claims.

Operation Number	Description	Time
A40-22120-1	MSDs Removal Label and Installation	0.6 hrs

Table 2 Labor Information

WARRANTY CLAIMS

Warranty claim expense is to be charged to Warranty. Claims are to be submitted in the normal manner, making reference to Field Service Campaign 22120.

Section 7 of the Warranty Policy and Procedures Manual contains further information related to the submission and processing of AFC / Recall claims.

As with all claim submissions, items acquired locally must be submitted in the “Other Charges” tab. The cost of any bulk items (such as a bag of cable tie straps, roll of wire, barrel of oil, or tube of silicone) should be prorated for the cost of the individual pieces / amount used during each repair.

To make sure this important improvement is made in a timely manner, all claims for 22120 activity must be submitted by 10 November 2023 or within the normal warranty period for the component repaired, if after 10 November 2023.

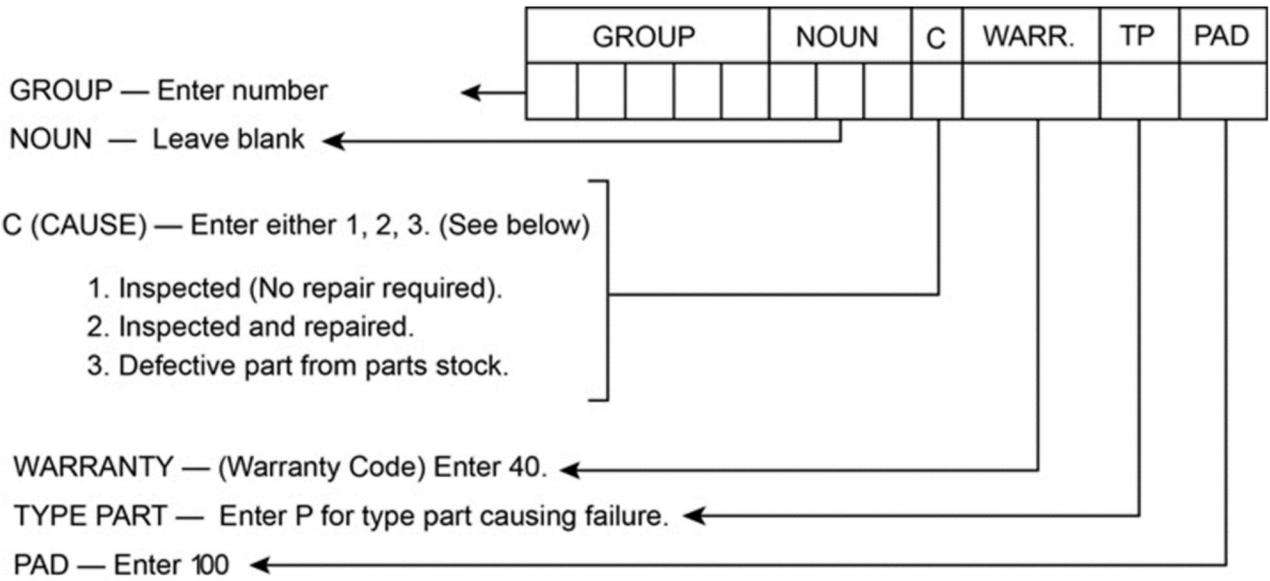

0000047910