

GLOBAL SAFETY FIELD INVESTIGATIONS
DCS6355
URGENT - DISTRIBUTE IMMEDIATELY

Date: December 6, 2022
Subject: N222387720 - Service Update
Outer Body Panel Split
Models: 2023 Cadillac XT6
To: All General Motors Dealers

General Motors is releasing Service Update N222387720 today. The total number of U.S. vehicles involved is approximately 173. Please see the attached bulletin for details.

Global Warranty Management (GWM)

The Required Field Action section on the Investigate Vehicle History (IVH) screen will be updated December 6, 2022. A list of vehicles in dealer inventory is attached to this message. Please hold all warranty transactions until IVH has been updated.

END OF MESSAGE

GLOBAL SAFETY FIELD INVESTIGATIONS

Service Update

N222387720 Outer Body Panel Split



Release Date: December 2022

Revision: 00

Attention: This service update involves vehicles in dealer inventory only and will expire December 31, 2023.

Make	Model	Model Year		RPO	Description
		From	To		
Cadillac	XT6	2023	2023		

This service update should be performed on vehicles in dealer inventory only. Involved vehicles are marked "Open" on the Investigate Vehicle History screen in GM Global Warranty Management system. This site should always be checked to confirm vehicle involvement prior to beginning any required inspections and/or repairs.

Condition	Certain 2023 model year Cadillac XT6 vehicles may have a split in the outer body panel above the left hand rear window.
Correction	Dealers will inspect the outer body panel, and if necessary remove the glass, weld and paint.

Parts

Quantity	Part Name	Part No.
1	Urethane Window Installation Kit	NPN*

* This kit can be purchased from a local automotive supplier. **Do not order from GMCCA.**

Warranty Information

Labor Operation	Description	Labor Time	Trans. Type	Net Item
9106561	Inspect Only – No Further Action Required	0.3	ZFAT	N/A
9106562	Repair Quarter Panel Metal (Includes Inspection, Repair and Refinish)	10.7		*

* The amount identified in "Net Item" should represent the actual sum total of the current GMCCA Dealer net price for the urethane window installation kit and paint/material allowance needed to perform the required repairs, not to exceed \$257.88 USD, \$336.00 CAD, plus applicable Mark-Up or Landed Cost (for Export). **Do not order from GMCCA.**

Service Procedure

TIP: Use a flashlight to illuminate the area of inspection, the crack is in a recessed area of the sheet metal.

- Carefully inspect the area above the left quarter panel window for a cracking condition. This condition will be directly above the glass to body seal.

Service Update
N222387720 Outer Body Panel Split

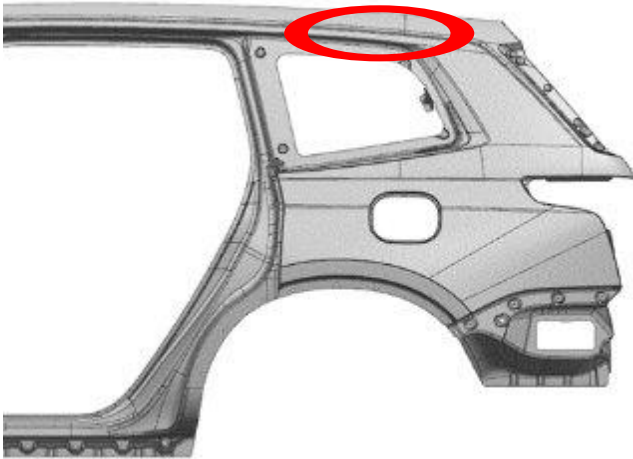

6203012



6203019

Service Update

N222387720 Outer Body Panel Split



6203023

- If no cracking condition is found, no further action is required.
 - If a cracking condition is found, proceed to step # 2.
2. Remove the left quarter panel glass. Refer to *Quarter Window Replacement* in SI.
 3. Remove the left front, rear and 3rd. row roof rail airbag from the work area, it is not necessary to remove the complete assembly. Refer to *Front, Rear, and 3rd Row Roof Rail Airbag Replacement* in SI.
 4. Remove the left rear body structure stop lamp. Refer to *Rear Body Structure Stop Lamp Replacement* in SI.
 5. Move any wiring or flammable insulation from the inside of the repair area.
 6. Disconnect the negative battery cable. Refer to *Battery Negative Cable Disconnection and Connection* in SI.

WARNING: Refer to [Approved Equipment for Collision Repair Warning](#) In SI.

WARNING: Refer to [Glass and Sheet Metal Handling Warning](#) In SI.

IMPORTANT: Cover all the surrounding panels and interior trim with weld blankets to prevent damage from weld splatter/grinding debris.

7. Using a small abrasive wheel, remove the paint and primer from the repair area.

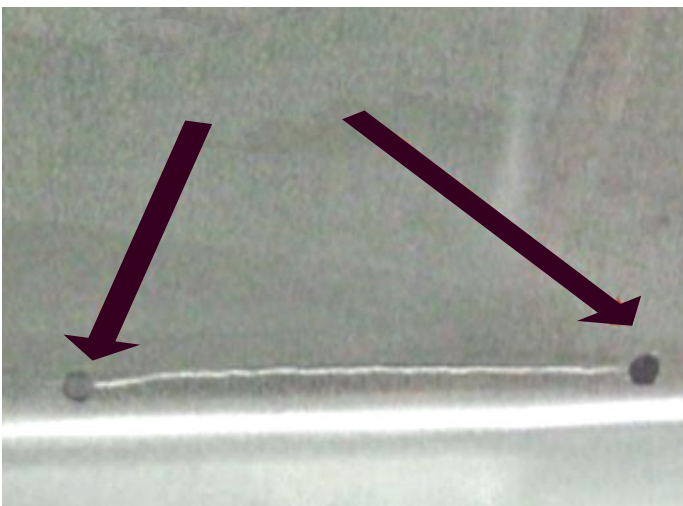

6203026

Service Update

N222387720 Outer Body Panel Split



8. Drill a 3.1mm (1/8 In.) hole at the two ends of the crack. This will prevent the crack from spreading.
9. MIG stitch weld the crack. **Use care, the metal is a thin gauge.** To avoid overheating the area, stitch weld 13mm (½ In.), leave a 13mm (½ in.) gap. Once this 13mm (½ in.) weld, gap pattern is completed, go back and fill in the gaps to complete the full length of the weld.
10. Metal finish the weld and prepare the repair area for paint.
11. Prime and paint the repair area as required. Refer to *Basecoat/Clearcoat Paint Systems* in SI.
12. Reinstall any wiring or flammable insulation that was removed from the inside of the repair area.
13. Reinstall the left front, rear and 3rd. row roof rail airbag as required. Refer to *Front, Rear, and 3rd Row Roof Rail Airbag Replacement* in SI.
14. Reconnect the negative battery cable. Refer to *Battery Negative Cable Disconnection and Connection* in SI.
15. Reinstall the left rear body structure stop lamp. Refer to *Rear Body Structure Stop Lamp Replacement* in SI.
16. Reinstall the left quarter panel glass. Refer to *Quarter Window Replacement* in SI.

Dealer Responsibility

Dealers must take the steps necessary to ensure that the service update correction has been made to all involved vehicles in dealer inventory before selling or dealer-trading the vehicle, but no later than December 31, 2023.

All new, used, GM Certified Used, courtesy transportation vehicles, dealer shuttle vehicles, etc. in dealers' possession and subject to this bulletin must be held and inspected/repared per the service procedure of this bulletin before customers take possession of these vehicles. Involved vehicles must be held and not delivered to customers, dealer-traded, released to auction, used for demonstration, or any other purpose.

All GM Certified Used vehicles currently in the dealers' inventory within the Certified Pre-Owned Inventory System (CPOIS) will be de-certified and must be held and remedied per the service procedure in this bulletin. Upon submitting an accepted/paid warranty transaction in the Global Warranty Management (GWM) system, the vehicle can be re-certified for sale within the CPOIS system, or once again be used in the CTP program.

Dealer Reports – For USA & Export

The Inventory tab of the Open Vehicle Report will contain Service Update Bulletin VINs that apply to this field action. This information is intended to assist dealers with the **PROMPT COMPLETION** of these vehicles. The Customer In-Service tab will not contain Service Update Bulletin VIN data because the intent of a Service Update Bulletin is to not inconvenience a customer with a special trip for service. Service Update Bulletins are to be completed when the customer is in for a regularly scheduled visit.

