

## Technical product information

<b>Topic</b>	Convertible hood cannot close - Header trim flap eyelet broken
<b>Market area</b>	Bentley: worldwide (2WBE)
<b>Brand</b>	Bentley
<b>Transaction No.</b>	2060120/6
<b>Level</b>	EH
<b>Status</b>	Released for publishing
<b>Release date</b>	07-Nov-2022

### New customer code

Object of complaint	Complaint type	Position
roof systems, special installations -> convertible roof, folding roof operation	functionality	

## Vehicle data

### New Continental GTC

#### Sales types

Type	MY	Brand	Designation	Engine code	Gearbox code	Final drive code
3S4*	2019	E		*	*	*
3S4*	2020	E		*	*	*
3S4*	2021	E		*	*	*
3S4*	2022	E		*	*	*
3S4*	2023	E		*	*	*

## Documents

Document name
<a href="#">master.xml</a>
<a href="#">headertrim.pdf</a>

## Customer statement / workshop findings

Convertible hood cannot close/latch due to a broken eyelet. The eyelet is part of the trim flap assembly (Figure 1)



Figure 1

TIP: In the event the hood is required to be closed prior to conducting the repair within this TPI, the operative should follow the manual assist procedure to allow the hood to fully close and latch as per the video located within the Bentley Hub reference TPI 2060120/-

IMPORTANT: Great care must be taken when conducting the manual assist procedure

## Technical background

Before conducting the instructions within this TPI, the operative must check and confirm that EC06 (SC21/24) is VIN applicable.

In the event that EC06 (SC21/24) is VIN applicable the operative must conduct the Service Campaign to completion

NOTE: In the event that EC06 (SC21/24) is not VIN applicable the operative must follow the instructions within this TPI (2060120/-) once complete the operative must raise a Technical DISS query stating the following:

- EC06(SC21/24) was VIN applicable and was conducted to completion

Or

- EC06(SC21/24) was not VIN applicable however the instructions within this TPI (2060120/-) were successfully conducted to completion

A kit of parts to replace the right and left hand trim flaps is now available (Figure 2)

NOTE: The trim flaps should be replaced in pairs

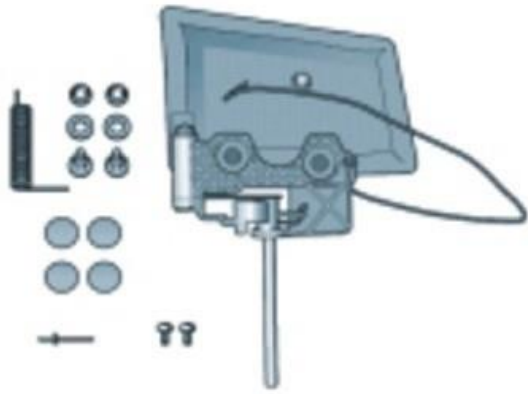

Figure 2

## Production change

-

## Measure

CAUTION: The Operative MUST ensure that all interior/exterior trim assemblies are suitably protected. Warranty payments will not be considered under any circumstances for any damage

1) Replace the right and left hand trim flaps - Rep.Gr 61

-

In the event the header trim panel procedure is not visible for the applicable VIN please refer to the attached instruction document (PDF)

## Warranty accounting instructions

### Header trim removed and refitted

Warrantytype 110 or 910

Damage service number 61 21

Damage code 00 10

### Labour

Labour Operation Code 61 21 19 01

Time 30 Time units

### Right and left hand Flap assemblies replaced

### Labour

Labour Operation Code 61 92 56 50

Time 20 TU

## Parts information

Refer to the ETKA parts catalogue

## General Information

The header trim panel must be removed in order to remove the header trim panel flaps.

## Special tools and workshop equipment required

- ◆ None

## Torque tightening values

Unless otherwise shown, standard torque values apply. ⇒ [/BAS/After Sales Publication/Body/00 - Technical data, Materials](#)

## Single use items

Within this procedure there are single use items which must be replaced and not reused. Ensure that new replacements are available prior to starting this procedure.

## Removal

- Remove the header trim panel. Refer to “Convertible hood header trim panel - To remove and fit”. ⇒ [/BAS/After Sales Publication/Body/61 - Convertible top, Hardtop, Canopy](#)
- Place the header trim panel onto a protected surface.
- Remove and dispose of the 2 fixings **-arrowed-**, (3.5 Nm).

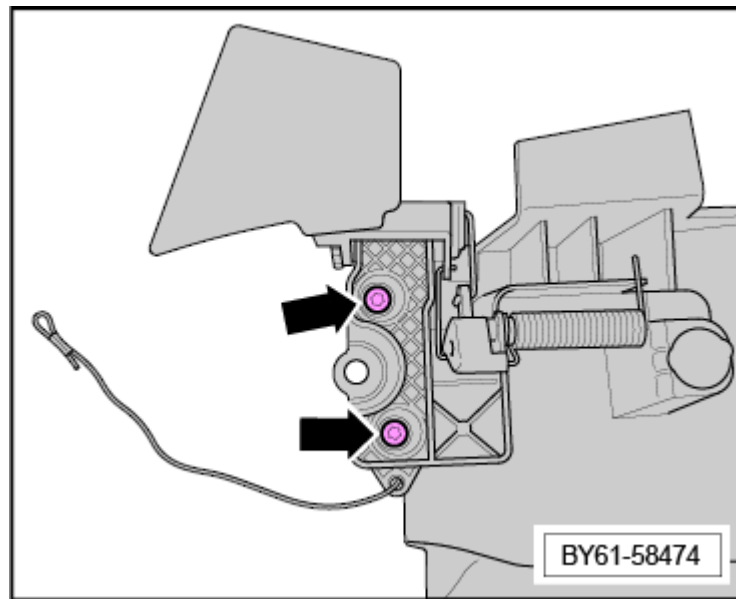

- Raise the torsion spring leg **-1-**, and slide the flap assembly **-2-** outwards, off the trim panel **-3-**.

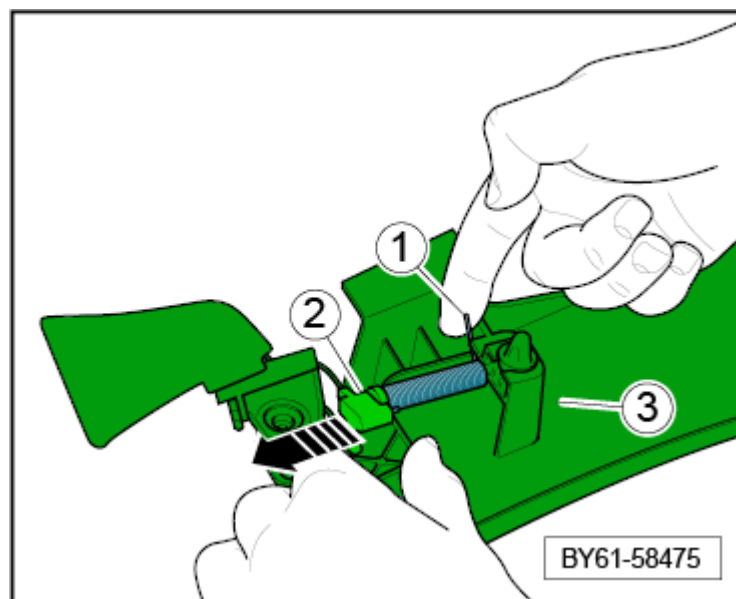

### Note

Ensure that the bushing **-1-** remains in place in the header trim panel **-2-**.

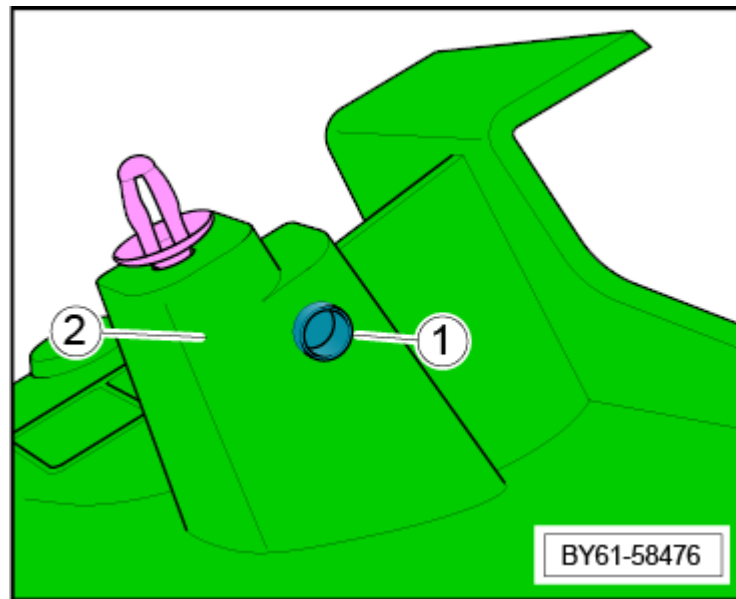

- If replacing the header trim panel flap assembly and re-using the torsion spring, remove the torsion spring **-1-** by sliding it off the shaft **-2-**.

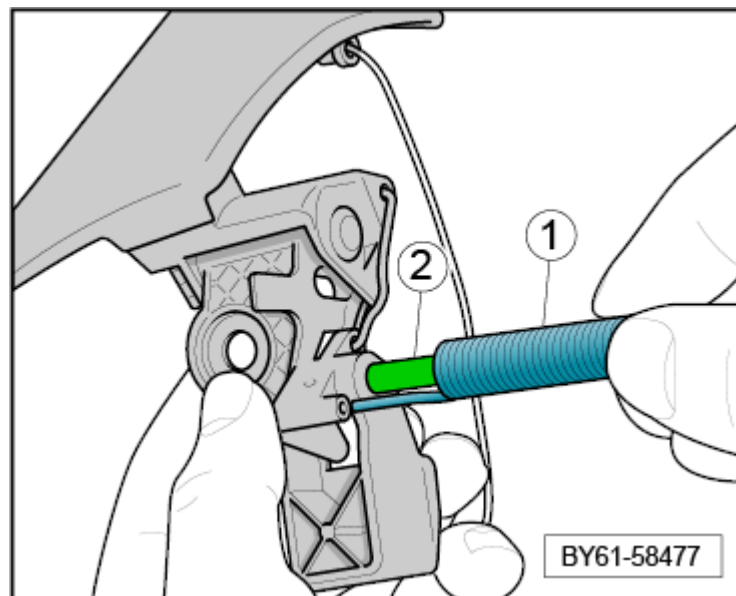

## Installation

Installation is the reverse of removal procedure, noting the following:

- If it has been removed, refit the torsion spring to the shaft, ensuring that the leg **-1-** locates fully in the hole **-2-**.

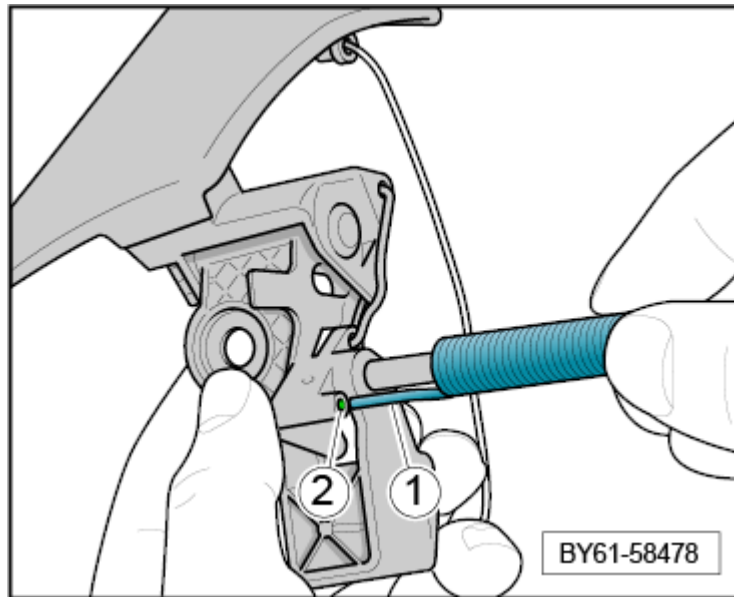

- Pull the torsion spring leg **-1-** upwards slightly, check that the bushing **-3-** is in place, and insert the shaft **-4-** into the bushing.

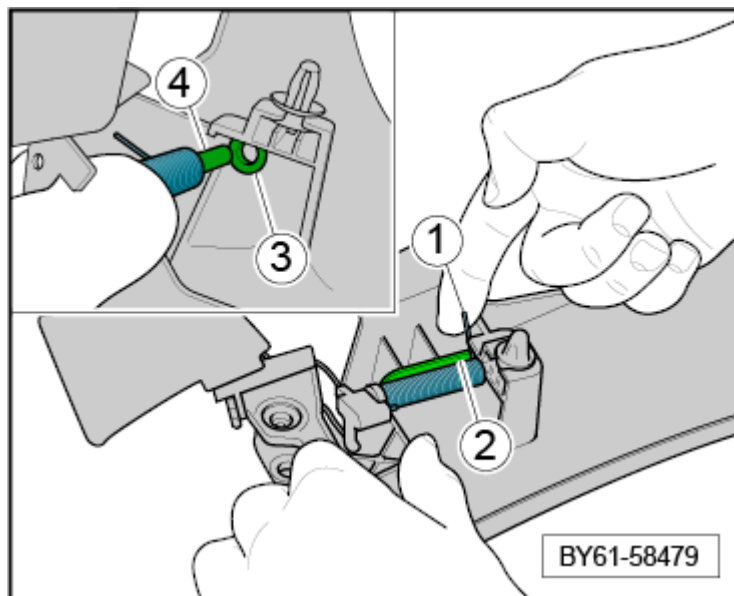

- Gently release the torsion spring leg so that it sits on the “rib” **-2-** of the header trim panel.



### Note

*Ensure that both torsion spring legs are correctly located.*

- Place the 2 washers **-arrowed-**, into position between the

header trim panel flap assembly **-1-** and the header trim panel **-2-**, and using 2 new fixings, loosely assemble the flap assembly to the header trim panel.

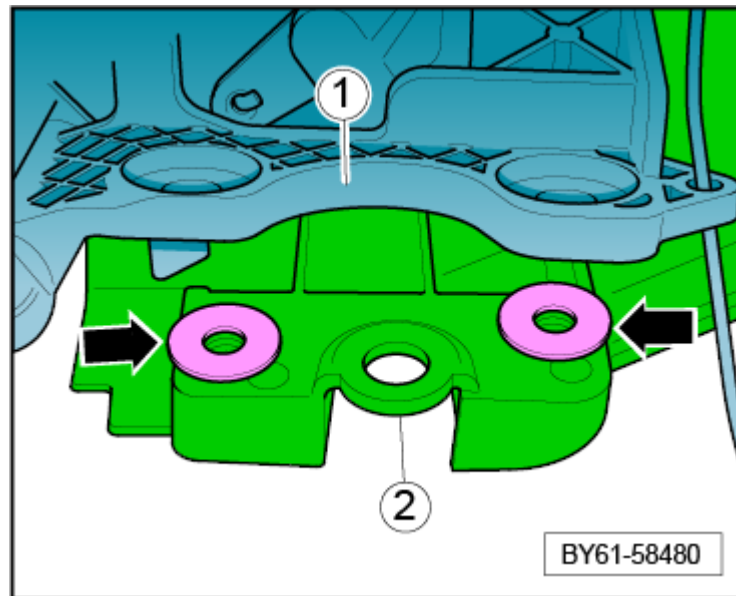

### Note

*Do not tighten the fixings at this point.*

- Align the flap assembly to the header trim panel, ensuring that the edges **-1-** of the two panels align, and that the gap **-arrowed-** between the two panels is 2.5mm (+0.5/-1.5) and consistent along the whole length .

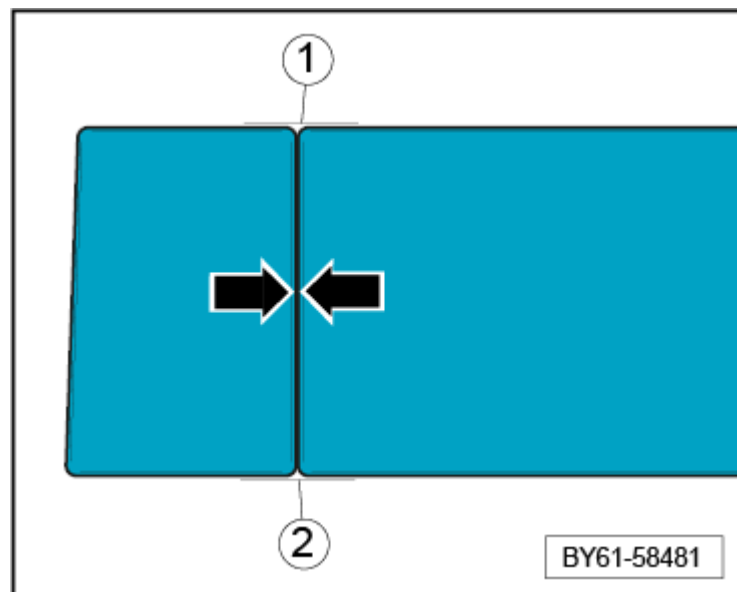



## Caution

***Misalignment of the panels can cause damage to both the header trim panel and the header trim panel flap assembly.***

---

- Torque tighten the fixings **-arrowed-**.

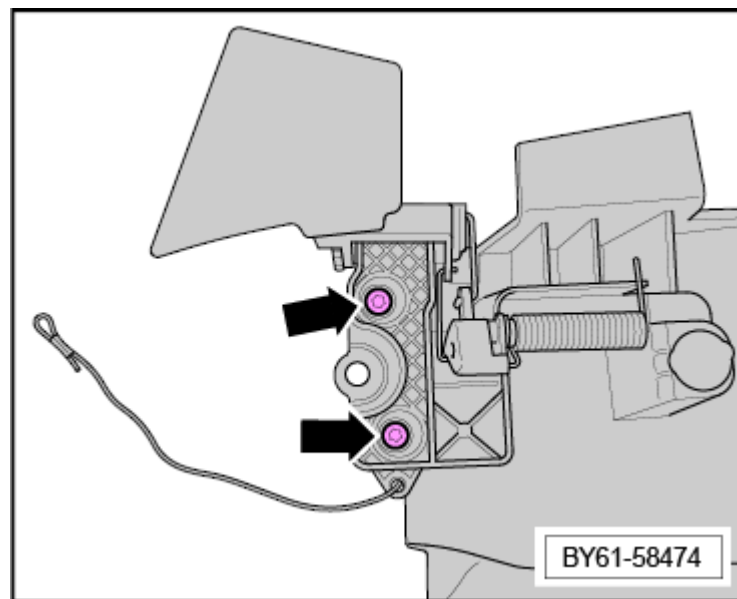

- Open and close the convertible roof, and check that the gap between the header trim panel flap assembly and the header trim panel are within the tolerance specified above. Adjust if necessary.