



CR243 – Rear Shock Protector Installation

Desert X Model Year 2023 (all country versions)
Technical Service Bulletin SRV-TSB-22-017

Date: November 30, 2022
To: Dealer Principal, General Manager, Service Manager, North American Dealer Network
From: Richard Kenton, Technical Director
Dan Schwartz, Service Area Manager

Dear Dealers,

We would like to inform you that the new Rear Shock Absorber Protector **part no. 4601N841A** has been introduced into the production line as of September 13th, 2022, starting from frame number ZDM1X00AAPB004049.

This Workshop Campaign is to extend the possibility of installing the new Rear Shock Absorber Protector on Desert X models manufactured before the above-mentioned frame number. In order to carry out this upgrade, the following components must be ordered in the quantities indicated:

Part no.	Description	Image	Quantity
4601N841A	Rear shock absorber protector		1
77244213B	TBEI screw M5x20		2
71614291AB	Spacer with collar 5.2x8x16		2
71314111A	Spacer 5.2x16x5		2



CR243 – Rear Shock Protector Installation



Desert X Model Year 2023 (all country versions)
Technical Service Bulletin SRV-TSB-22-017

Table of contents

	Page
Introduction	1
Application	2
Customer Impact	2
Parts Distribution	2
Warranty Reimbursement Rules	3
Spare Parts	3
Service Solution	4

Application

You can find the precise list of VIN numbers involved in CR243 on the DCS, in sections:

VIN HISTORY		It is possible to search by individual frame number.
CAMPAIGNS		It is possible to search for all the frame numbers that you received from Ducati Motor Holding.

Customer Impact

All motorcycles in your inventory (to be registered or already registered) and to be delivered to Clients must be updated during pre-delivery operations and always before delivery to the final Client. All motorcycles already delivered to final Clients must undergo this inspection as soon as they come to your workshop. Note: this is NOT a safety recall.

Parts Distribution

The components required to carry out the upgrade under this Workshop Campaign must be ordered for each affected frame number.

- Rear Shock Absorber Protector part no. 4601N841A
- 2 screws M5x20 part no. 77244213B
- 2 spacers part no. 71614291AB
- 2 spacers part no. 71314111A



CR243 – Rear Shock Protector Installation

Desert X Model Year 2023 (all country versions)
Technical Service Bulletin SRV-TSB-22-017

Warranty Reimbursement Rules

Reimbursement for work associated with this Service Campaign will be made through the regular warranty claim procedure using the “VIN History” section of the DCS. The warranty claim is pre-filled and is identified as CR243.

The dealership will be reimbursed for the required parts listed for the operation; Rear shock absorber protector part no. 4601N841A, 2 screws M5x20 part no. 77244213B, 2 spacers part no. 71614291AB, 2 spacers part no. 71314111A; and labor of [REDACTED] that includes the time necessary for:

- Vehicle reception and return
- Installation of the rear shock protector
- Consumables for carrying out the work
- Soft cleaning of the vehicle

Spare Parts

Part no.	Description	Image	Quantity
4601N841A	Rear shock absorber protector		1
77244213B	TBEI screw M5x20		2
71614291AB	Spacer with collar 5.2x8x16		2
71314111A	Spacer 5.2x16x5		2



CR243 – Rear Shock Protector Installation

Desert X Model Year 2023 (all country versions)
Technical Service Bulletin SRV-TSB-22-017

Service Solution



WARNING

To ensure the correct execution of the operation within the provided labor time to carry out the update, it is necessary to follow the sequence indicated in the following instructions.

We recommend taking your time to fully understand the procedure before attempting its implementation on the motorcycle (you may print the document in color for a better understanding).

1. Position the motorcycle on the rear paddock stand.
2. Remove the 2 screws M5x9 (1) and remove the rear mudguard (2).



NOTE

The 2 screws M5x9 (1) will be reused to mount the rear shock absorber protector.

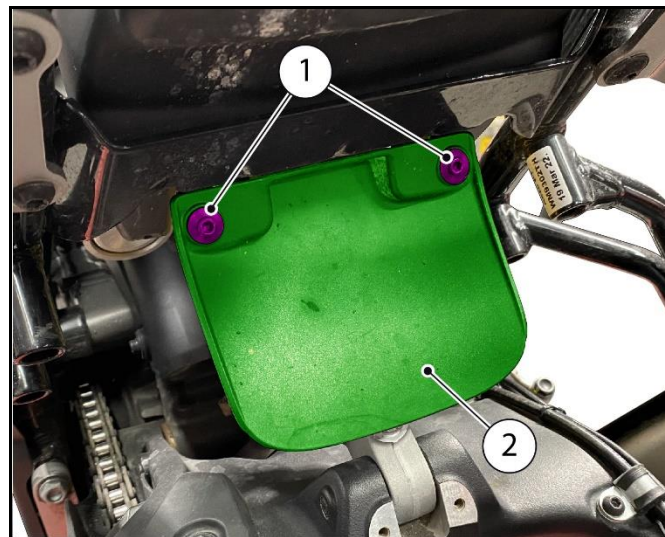



CR243 – Rear Shock Protector Installation

Desert X Model Year 2023 (all country versions)
Technical Service Bulletin SRV-TSB-22-017

3. Reinstall the rear mudguard (2) with the 2 screws M5x20 (5), 2 spacers (6) part no. 71614291AB and 2 spacers (7) part no. 71314111A, as shown in the figure.

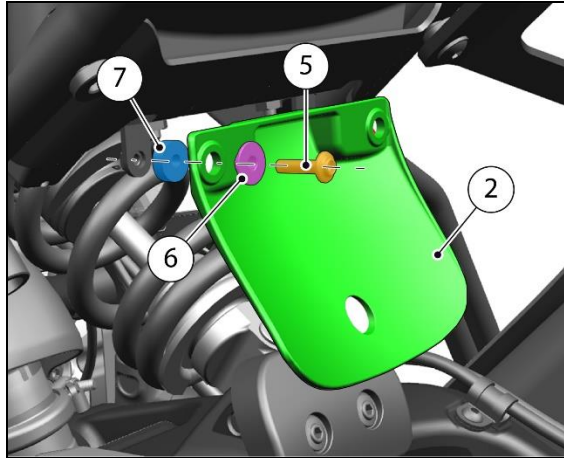

4. Tighten the screws M5x20 (5) to a torque of $5 \text{ Nm} \pm 10\%$.

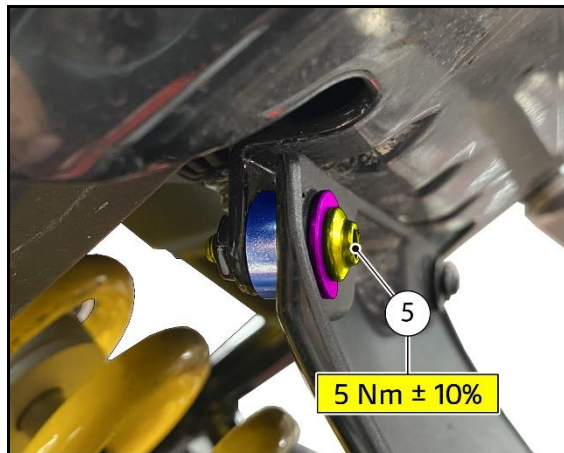
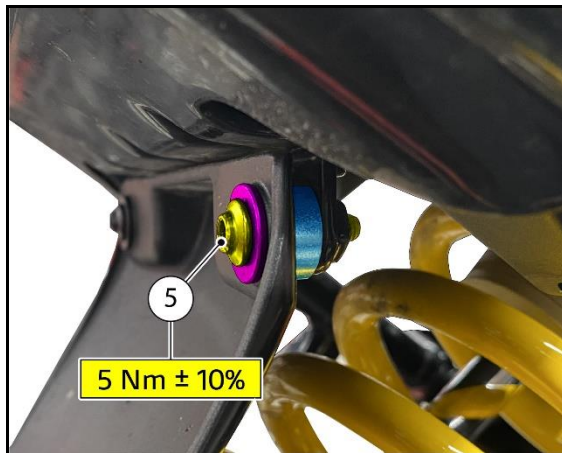



CR243 – Rear Shock Protector Installation

Desert X Model Year 2023 (all country versions)
Technical Service Bulletin SRV-TSB-22-017



WARNING

Before positioning the rear shock absorber protector, carefully clean the inside of the holes for the protector fixing screws.

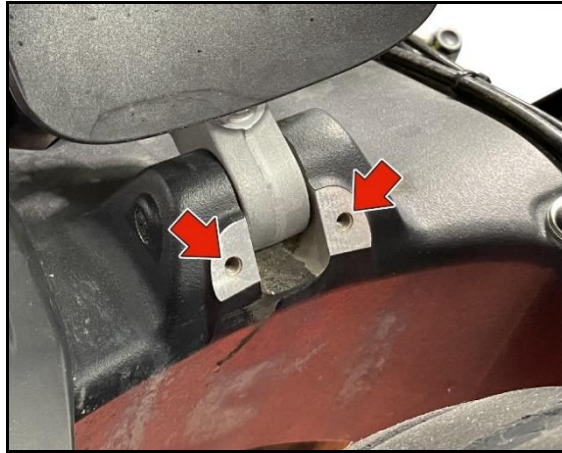

5. Clean the threads of the **M5x9** screws previously removed from the rear mudguard and apply **Loctite 243**.





CR243 – Rear Shock Protector Installation

Desert X Model Year 2023 (all country versions)
Technical Service Bulletin SRV-TSB-22-017

6. Position the rear shock absorber protector (3) with the 2 M5x9 screws (1). Tighten the screws M5x9 (1) to a torque of 5 Nm ± 10%.

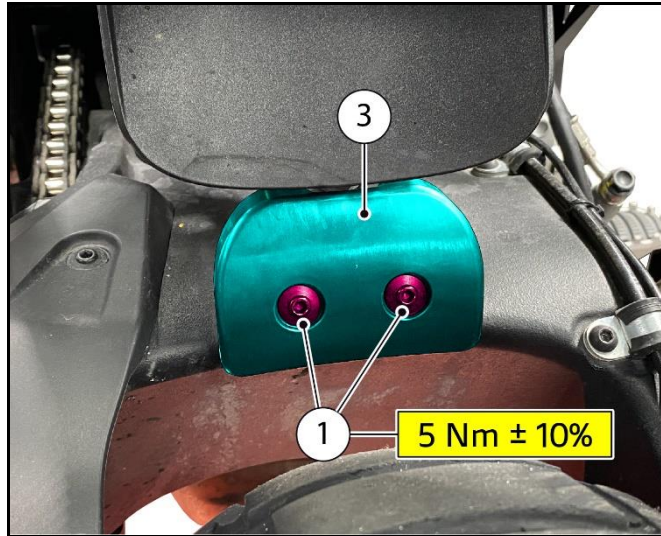

7. Remove the rear paddock stand.

For questions on this Service Update Campaign,
please contact your Service Area Manager.