

Technical Service Bulletin

Topic	Bentayga V8 Kovomo - DTC P310B00 with Symptom Code 2638 - Check Engine Lamp - Fuel Pressure Regulation
Market area	Bentley: worldwide (2WBE)
Brand	Bentley
Transaction No.	2058484/10
Level	EH
Status	Released for publishing
Release date	Nov 22, 2022

Diagnostic trouble codes

Diagnostic address	Diagnostic trouble code	Fault symptom	Storage state
0001 - Engine electronics	P310B00: Fuel low pressure regulation Fuel pressure outside specification		static
0001 - Engine electronics	P310B00: Fuel low pressure regulation Fuel pressure outside specification		Intermittent

New customer code

Object of complaint	Complaint type	Position
engine -> engine operation	functionality	
engine -> engine operation -> engine output characteristic	functionality -> misfire	

New workshop code

Object of complaint	Complaint type	Position
engine -> operation, engine control -> engine control module	functionality -> misfire	
engine -> operation, engine control -> engine control module	control modules, services -> with fault stored in the DTC memory	
engine -> operation, engine control -> engine control module	control modules, services -> measured value too high	
engine -> operation, engine control -> engine control module	electrical -> ground connection damaged	
engine -> fuel supply -> low pressure fuel pump, tank side	functionality -> irregular	
engine -> operation, engine control -> engine control module	control modules, services -> error message	

Vehicle data

Bentayga Series - V8 Kovomo

Sales types

Type	MY	Brand	Designation	Engine code	Gearbox code	Final drive code
4V14D9	2018	E		*	*	*
4V14D9	2019	E		*	*	*
4V14D9	2020	E		*	*	*
4V14D9	2021	E		*	*	*
4V14D9	2022	E		*	*	*
4V14D9	2023	E		*	*	*
ZV14D9	2023	E		*	*	*

Documents

Document name
master.xml

Condition

Engine warning lamp is illuminated within the Driver Instrument Panel (DIP) in conjunction with the DTC as detailed below:

- ***"P310B00 with symptom code 2638 - Low Fuel Pressure Regulation"***

There may also be multiple DTC's and symptoms present due to fuel pressure regulation or fuel supply issues in conjunction with the aforementioned symptom/DTC

Technical Background

NOTE: The retailer must attempt to request as much information as possible regarding when the issue occurred

Pre-conditions, For example:

- Driving at low speed in traffic
- Warning lights
- Driveability at the time the issue occurred - During idle or driving?
- If during idle, how long had the car been idling?
- Details when the vehicle was last refuelled and the grade of fuel used
- When the issue occurred, How was the car unlocked and started? Keyless entry or entry by using the remote key fob

IMPORTANT: All received information must be added to a new or existing technical DISS query

The operative should refer to the "Measure" section to determine the correct analysis and repair procedure.

Revision history

TPI 2058484/7

- Removal of country matrix from the Production change section

TPI 2058484/8

- Additional request to gather information from the customer (Technical background section)
- Measure section amended to include further checks prior to replacing the fuel delivery module
- Measure section revised to request the operative first confirms the ASAM 2D/ODX data record as shown in Figure 1

NOTE: The ASAM 2D/ODX data record suffix letter check is required to confirm the ASAM 2D/ODX data record suffix letter which will then confirm the applicable procedure (depending on suffix letter) in the example shown the suffix letter is 'E'



CAUTION: Please be aware there is a section within the Measure section which must be followed if the suffix letter is 'J'

<input type="checkbox"/> Identification:	
Data source:	Vehicle
Hardware part number:	0P2907309A
Part number:	9Y0909101E
Hardware version number:	H31
Software version number:	0002
Production date:	12.04.2022
Coding:	<input type="checkbox"/>
Coding:	1D2A003225661905343800000000000000000000000000000000
Flash capability:	unknown
System designation:	V8 4.0i TFS
ASAM base variant:	BV_EnginContrModul1UDS
ASAM 2D/ODX data record:	EV_ECM40TFS0119Y0909101E
ASAM 2D/ODX data record version:	002002
ASAM/ODX CU variant used:	EV_ECM40TFS0119Y0909101E_002
Equipment code:	00 00 00 00 00 00 00 00
System abbreviation:	----

Figure 1

Production Solution

-

Service

1) Using ODIS - Confirm the fuel level within the tank (litres) matches the level of fuel that is shown within the DIP

- Take a photograph of the fuel level shown within the DIP
- Take a screen shot from ODIS showing the amount of fuel (litres) within the fuel tank
- Attach both to a new or existing technical DISS query

2) Referring to Rep.Gr 20 - Carry out a low pressure fuel system check - Low pressure fuel system - To test

- Attach clear photographs of the low pressure fuel system manual gauge results to a new or existing technical DISS query

3) Referring to Figure 1 - Check the Engine control module 1 data within the diagnostic log to confirm the ASAM 2D/ODX data record (ARROW) in the example shown in Figure 1, the suffix letter is 'E'

ASAM 2D/ODX data record is 9Y0909101J (Suffix letter 'J')

- In the event the suffix letter is 'J' - Referring to Figure 2 (ODIS diagnostic log screenshot) - Check and confirm the Fuel low pressure, actual value
- Take a note of the Fuel low pressure, actual value, the value in the example shown is **501.3kPa**
- In the event the Fuel low pressure, actual value is greater than or equal to 500kPa the operative should conduct the remaining instructions from Step 4

However

In the event the Fuel low pressure, actual value is lower than 500 kPa please proceed to Step 9

□

VERY IMPORTANT: For any other variant of the ASAM 2D/ODX data record (Suffix letter NOT J)

In the event the Fuel low pressure, actual value is greater than or equal to 475kPa the operative should conduct the remaining instructions from Step 4

However

In the event the Fuel low pressure, actual value is lower than 475kPa please proceed to Step 9

<input type="checkbox"/> Extended ambient conditions:		
Engine rpm	639.5	1/min
Normed load value	13.725490449999999	%
Vehicle speed	0	km/h
Coolant temperature	82	°C
Intake air temperature	42	°C
Ambient air pressure	1000	mbar
Voltage terminal 30	12.4	V
Dynamic environmental data	20 96 28 11 CE 11 94 11 C8 12 80 11 C9 F8 41 11 A4 26 66 12 8AAA 15 9F 66 60 15 A0 66 64	
Unlearning counter according OBD	40	
Low fuel pressure, specified value	450.0	kPa
Fuel low pressure, actual value	501.3	kPa
Fuel pump adaptation	-198.3	kPa
Fuel pump, specified value	14.99939	%
Fuel temperature	79.5	°C
Fuel high-pressure, actual value	13.104	MPa
Fuel pressure rail 2	13.106	MPa

Figure 2

IMPORTANT: Before proceeding - Have you confirmed the ASAM 2D/ODX data record?

NO - Please go back to Step 3 to confirm the ASAM 2D/ODX data record

Yes - Please continue from Step 4 to completion

4) Allow the engine to cool down to ambient temperature

5) Once cool, Referring to Figure 3 - Navigate to the following IDE's

Selection

[IDE00186]_Fuel low pressure, actual value

[IDE00202]_Low fuel pressure, specified value

[IDE00357]_Fuel temperature

Figure 3

- Before conducting the next steps take a screen shot of the values of the IDE's shown in Figure 3 and attach a current ODIS log to a new or existing technical DISS query

Ensure the vehicle is parked within a well ventilated area, exhaust extraction must be used if in the workshop

6) Allow the engine to idle for a minimum of 10 minutes (ensuring the vehicle is in a well ventilated area using exhaust extraction if in the workshop)

- Using ODIS monitor the Fuel low pressure, actual value readings every 60 seconds for a further 10 minutes

7) Attach the Fuel low pressure, actual value readings to a new or existing DISS query

8) Allow the engine to idle for a minimum of 10 minutes

9) Using ODIS - Check the "Adaption of Fuel Pump (FP)" value within the fault memory

To check the "Adaption of Fuel Pump (FP)" value within the fault memory, refer to Engine control Unit "01 - Engine Control Module 1" - From "Extended ambient conditions" note the value of the "Adaption of Fuel Pump (FP)" - Figure 4

10) Take a screen shot from ODIS showing the Adaption of fuel pump vale (FP) and attach the current ODIS log to a new or existing technical DISS query

Initial system test with fault memory entries

Address: 0001 System name: 01 - Engine Control Module 1 Protocol variant: UDS/ISOTP (Ereignisse: 1)

+ Identification:

- Event memory entries (Data source: Vehicle):

Entry in fault memory

Number: P310B00: Low Fuel Pressure regulation Fuel pressure outside specification
Fault type 2: passive/sporadic
Symptom: **2638**
Status: 10101000

- Standard ambient conditions:

Date: 05/11/19
Time: 09:52:18
Mileage (DTC): 92
Priority: 2
Frequency counter: 8
Unlearning counter / driving cycle: 255

- Extended ambient conditions:

Engine speed	602.0	1/min
Normed load value	7.05882366	%
Vehicle speed	0	km/h
Coolant temperature	73	°C
Intake air temperature	15	°C
Ambient air pressure	1010	mbar
Voltage terminal 30	14.92	V
Dynamic environmental data	20 96 28 11 CE 11 94 11 C8 11 AE 11 C9 F9 E4 11 A4 26 66 12 8A A2 15 9F 44 D4 15 A0 44 A4	
Unlearning counter according OBD	40	
Low fuel pressure, specified value	450.0	kPa
Fuel low pressure, actual value	452.6	kPa
Adaptation of Fuel Pump (FP)	-156.4	kPa
Fuel pump, specified value	14.99999	%
Fuel temperature	73.5	°C
Fuel high pressure, actual value	8.81	MPa
Fuel pressure rail 2	8.786	MPa

Figure 4

11) In the event the value is between minus 100 to 200 kPa - the Fuel Delivery Module within the fuel tank (Figure 5) should be replaced - Refer

to Repair Group 20 Fuel supply, gas operation / 4.0L V8 TSI / Fuel pump, fuel level sensors, and jet pump (RH) - To remove and fit.

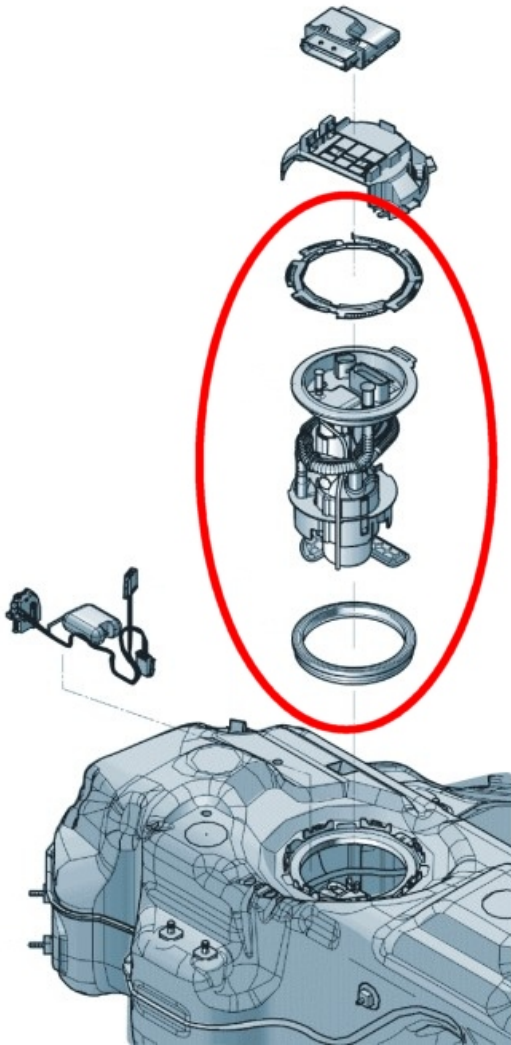

Figure 5

IMPORTANT: Once the fuel delivery module has been replaced, the operative should attach a clear of the manufacture information as per the example shown in Figure 6

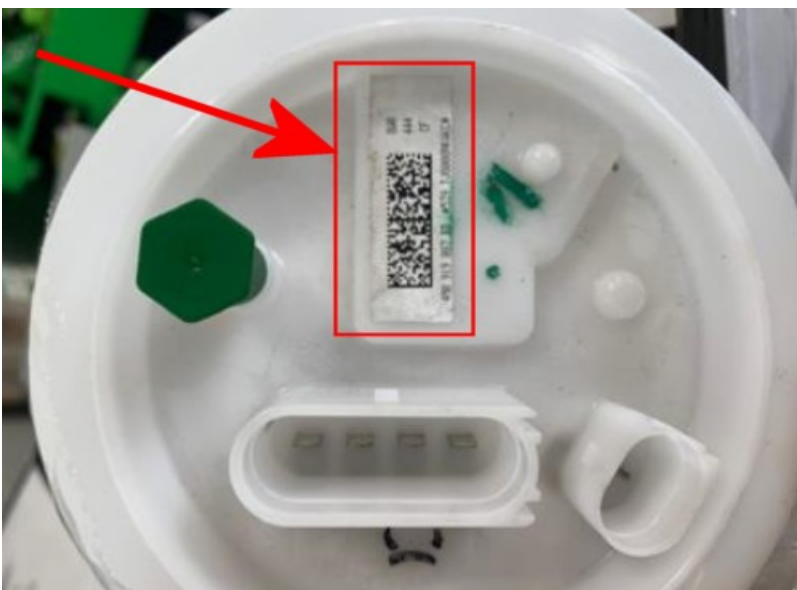

Figure 6

Warranty

Warranty type - 110 or 910

Damage Service Number 20 66

Damage Code 01 00

Time to conduct the low pressure fuel system check

Labour Operation Code 20 03 01 00 (use 99 index until 22/9/22)

Time 50 TU

Diagnosis time

Labour Operation Code 01 50 00 00

Time As per ODIS log (must not exceed 50 TU)

Time to replace the fuel delivery module

Labour Operation Code 20 66 19 50

Time 50 TU

Time to remove and refit the rear seats (4 seat)

Labour Operation Code 68 16 19 01

Time 190 TU

Time to remove and refit the rear seats (5 seat)

Labour Operation Code 72 48 20 05

Time 100 TU

Time to remove and refit the seat sill panel

Labour Operation Code 68 05 19 00

Time 20 TU

Time to remove and refit the boot side trim panel

Labour Operation Code 70 03 19 00

Time 40 TU

Required Parts and Tools

For the latest part information always refer to the Electronic Parts Catalogue – ETKA.