

**November 10, 2022**

Version 5

## Safety Recall: 2002-06 CR-V Driver's Power Window Switch (Only VINs that start with SHS)

Supersedes 20-122, dated May 10, 2022, to revise the information highlighted in **yellow**.

**IMPORTANT:** Confirm the vehicle's VIN starts with SHS before proceeding with this service bulletin. This bulletin only applies to 2002–06 CR-Vs with VINs that start with SHS. Refer to Service Bulletin 11-057 for 2006 CR-Vs with VINs starting with JHL.

### AFFECTED VEHICLES

Year	Model	Trim Level	VIN Range
2002-06	CR-V	ALL	Check the iN VIN status for eligibility. (VIN must start with SHS)

### REVISION SUMMARY

Under **WARRANTY CLAIM INFORMATION**, a note was added.

### BACKGROUND

Under severe conditions, water or other liquid may enter the driver's window and reach the power window master switch on the door panel. Liquid in the switch can damage the switch's printed circuit board (PCB), causing the switch to fail. In rare cases, the damaged PCB creates a short circuit that overheats the switch connectors and melts them, leading to a possible fire.

All affected vehicles, even those previously repaired under S/B 12-067, must have the driver's power window switch replaced under the current recall.

### CUSTOMER NOTIFICATION

Owners of affected vehicles will be sent a notification of this campaign.

Do an iN VIN status inquiry to make sure the vehicle is shown as eligible.

Some vehicles affected by this campaign may be in your new or used vehicle inventory.

Failure to repair a vehicle subject to a recall or campaign may subject your dealership to claims or lawsuits from the customer or anyone else harmed as a result of such failure. To see if a vehicle in inventory is affected by this safety recall, do a VIN status inquiry before selling it.

### CORRECTIVE ACTION

Remove the driver's power window master switch and inspect the driver's door wire harness connector. Based on your inspection, do one of the following:

- REPAIR PROCEDURE A: Replace the driver's power window master switch.
- REPAIR PROCEDURE B: Replace the driver's power window master switch and the driver's door wire harness.

NOTE: REPAIR PROCEDURE B is rare; the replacement rate is about 1 percent.

**CUSTOMER INFORMATION:** The information in this bulletin is intended for use only by skilled technicians who have the proper tools, equipment, and training to correctly and safely maintain your vehicle. These procedures should not be attempted by "do-it-yourselfers," and you should not assume this bulletin applies to your vehicle, or that your vehicle has the condition described. To determine whether this information applies, contact an authorized Honda automobile dealer.

## PARTS INFORMATION

Part Name	Part Number	Quantity
Switch Assy., Power Window Master	06357-S9A-509	1

## TOOL INFORMATION

Tool Name	Part Number	Quantity
KTC Trim Tool Set	SOJATP2014	1

## WARRANTY CLAIM INFORMATION

Operation Number	Description	Flat Rate Time	Defect Code	Symptom Code	Template ID	Failed Part Number
7441C9	REPAIR PROCEDURE A Replace the power window master switch.	0.4 hr	6WW00	P9D00	A20122A	35750-S9A-C05ZA
7441D0	REPAIR PROCEDURE B Replace the power window master switch and switch harness.	0.8 hr	6WW00	P9D00	A20122B	35750-S9A-C05ZA

**NOTE:** Due to the wire harness part number variation for each model trim, you may manually add the wire harness part number to template A20122B.

Skill Level: Repair Technician

## INSPECTION PROCEDURE

**NOTE:** Make sure not to damage any parts (such as the door panel and switch panel) on removal and installation.

1. Make sure the window is up, then using the appropriate trim tool, pry out the upper portion of the cover to release the hooks, then remove the cover.

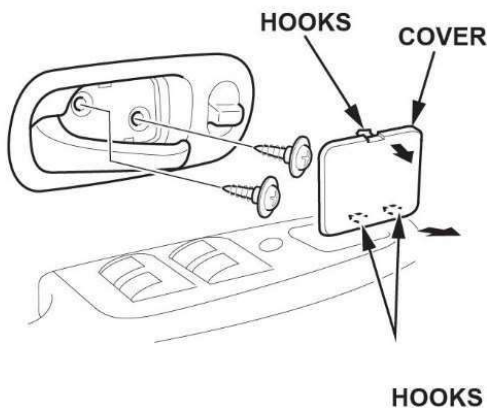

2. Remove the screws.

3. Release the power door lock switch bracket from the door panel by pulling the inner handle rearward and out halfway.

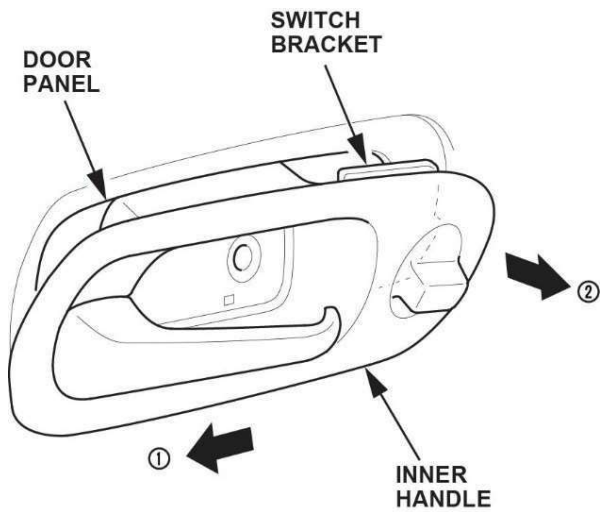

4. Disconnect the power door lock switch connector. Disconnect the inner handle rod and remove the inner handle.

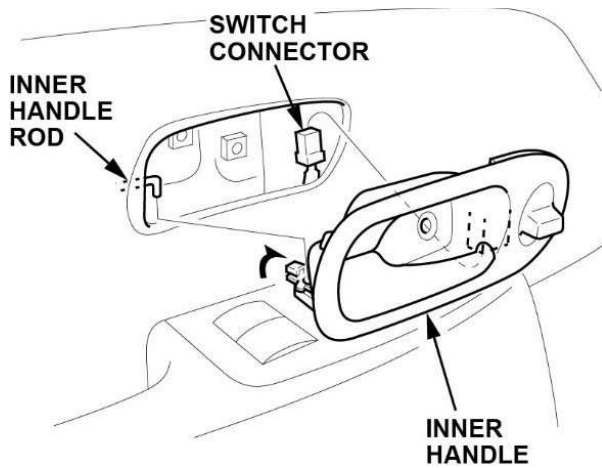

5. Remove the screws from under the armrest.

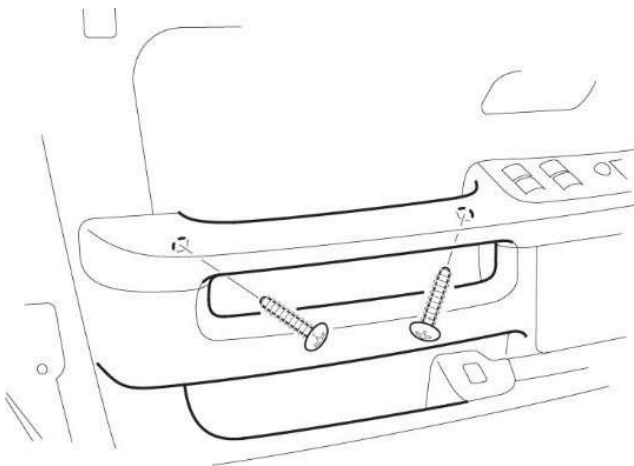

6. Carefully pry out the mirror mount cover by hand in the sequence shown.

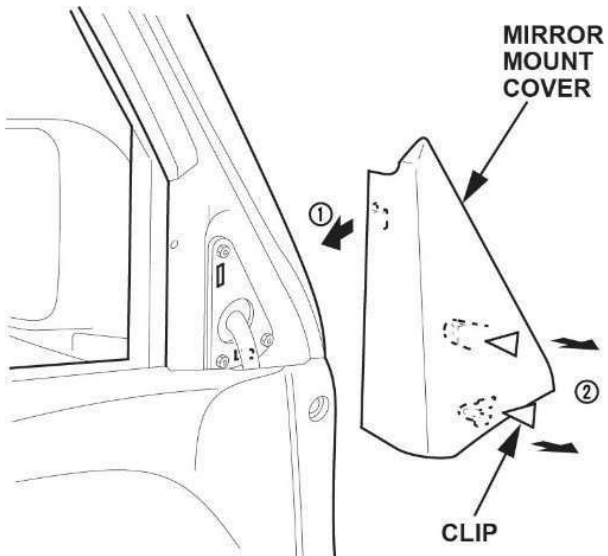

7. Remove the door panel by removing the clip. Then with the appropriate trim tool, pry up to release the clips that hold the door panel. Starting at the rear, pull the door panel upwards and release the lock knob.

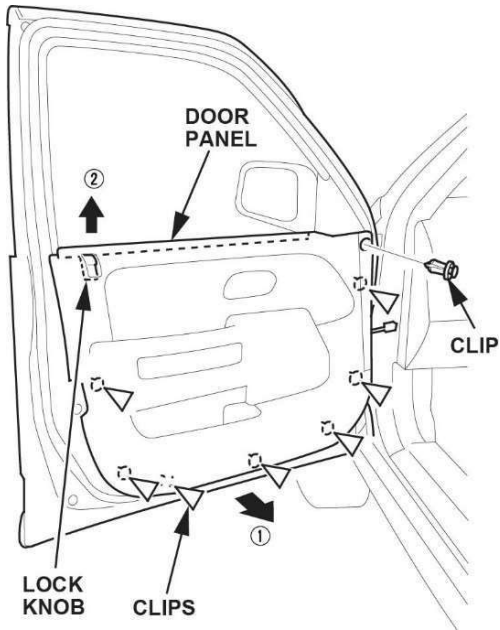

8. Disconnect the power window switch connector, the power mirror switch connector, and the hatch glass opener switch connector, and detach the harness clips from the back of the door panel.

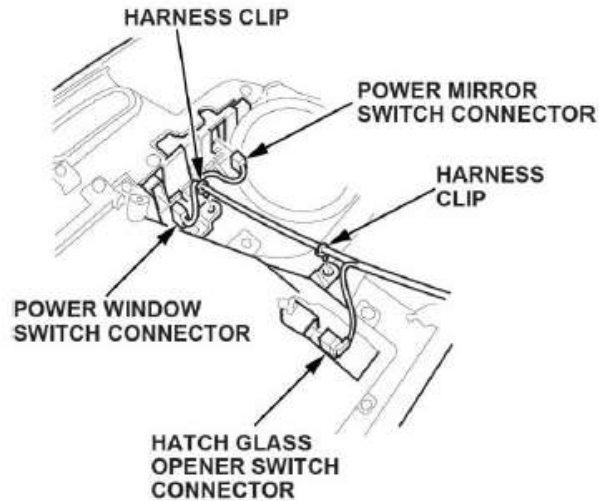

9. Push up on the bottom of the power window switch to release the clip and the hooks, then remove the switch.

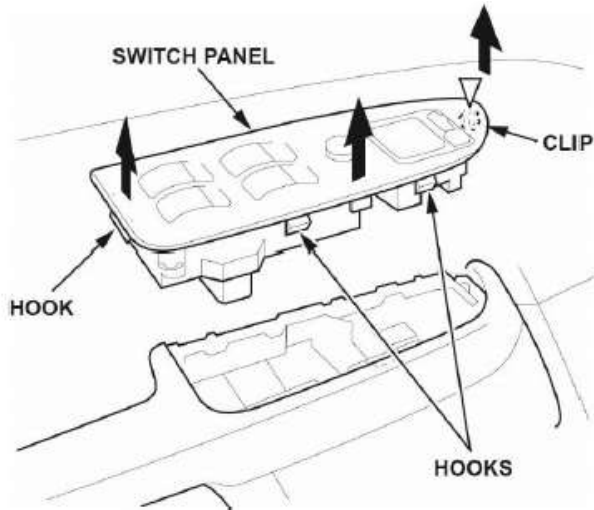

10. Inspect the power window switch and the driver's door harness connector for any heat damage or melting.
- If there is no damage to the driver's door harness connector, go to REPAIR PROCEDURE A.
  - If there is any damage to the harness connector, go to REPAIR PROCEDURE B.

## REPAIR PROCEDURE A

1. Remove the three screws that attach the switch to the switch panel. Using the three screws removed, install the new switch to the switch panel.

**02-04 CRV**

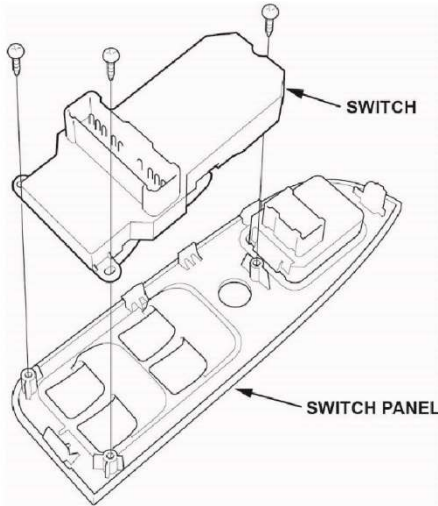

**05-06 CRV**

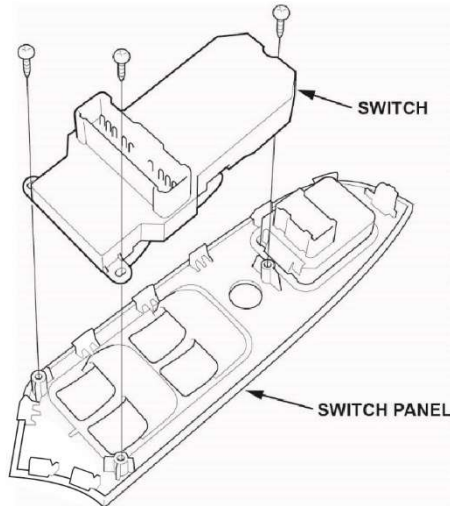

2. Reconnect the connectors.
3. Install all parts in the reverse order of removal.
4. Reset the power window control unit:
  - Turn the ignition switch to ON.
  - Move the driver's window all the way down by holding the driver's window switch firmly down; when the window reaches the bottom, hold the driver's window switch down for 2 seconds.
  - Move the driver's window all the way up by holding the driver's window switch firmly up; when the window reaches the top, hold the switch firmly up for 2 seconds.
  - If the window does not work in AUTO, turn the ignition switch to LOCK and repeat step 4.

## REPAIR PROCEDURE B

1. Replace the driver's door harness.

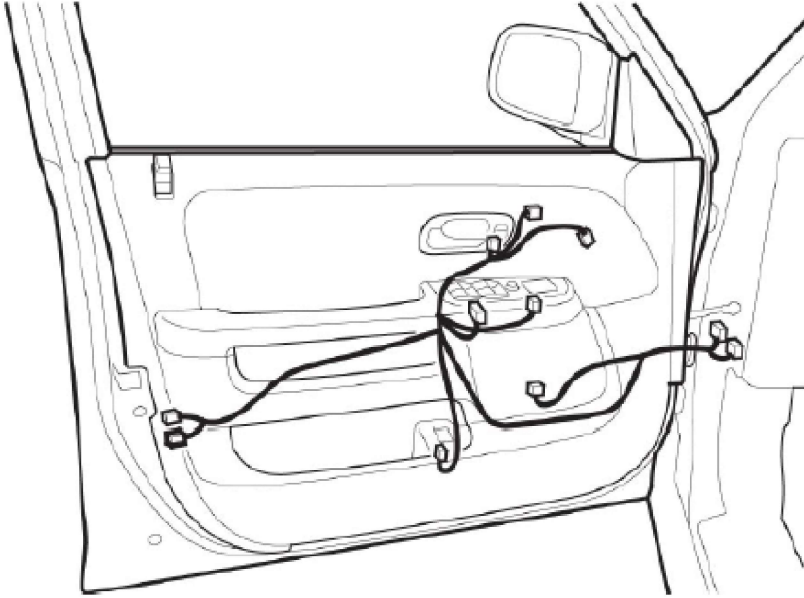

2. Install the new power window master switch to the switch panel.

*02-04 CRV*

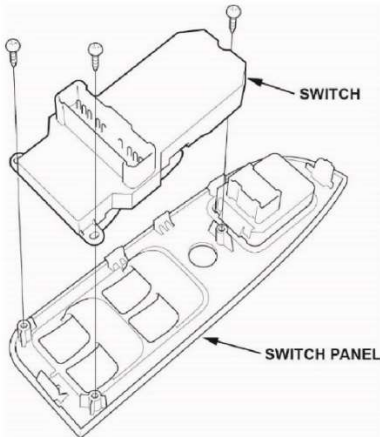

*05-06 CRV*

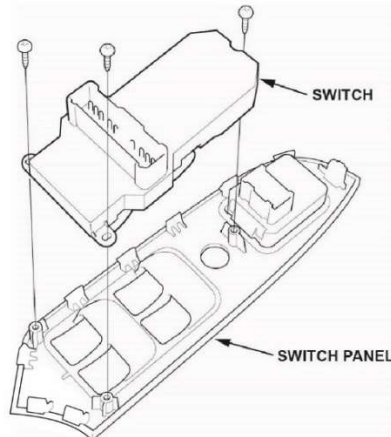

3. Install all parts in the reverse order of removal.
4. Reset the power window control unit:
  - Turn the ignition to ON.
  - Move the driver's window all the way down by holding the driver's window switch firmly down; when the window reaches the bottom, hold the driver's window switch down for 2 seconds.
  - Move the driver's window all the way up by holding the driver's window switch firmly up; when the window reaches the top, hold the switch firmly up for 2 seconds.
  - If the window does not work in AUTO, turn the ignition switch to LOCK and repeat step 4.

END