



INFINITI

TECHNICAL SERVICE BULLETIN

Classification:

DA22-003

Reference:

ITB22-037

Date:

November 4, 2022

SERVICE INFORMATION FOR DISTANCE SENSOR DTC DIAGNOSIS

APPLIED VEHICLES: 2022 QX60 (L51)

SERVICE INFORMATION

If DTC C2581-78 (Distance sensor) and/or C2581-92 (Distance sensor) are stored as **CURRENT** in the LASER/RADAR system, and there is no external impact damage to the outside of the front bumper fascia, the following **SERVICE PROCEDURE** must be followed prior to replacing any components.

- Impact damage to the front bumper fascia, distance sensor or distance sensor bracket is not warrantable, and not covered by this **SERVICE PROCEDURE**.

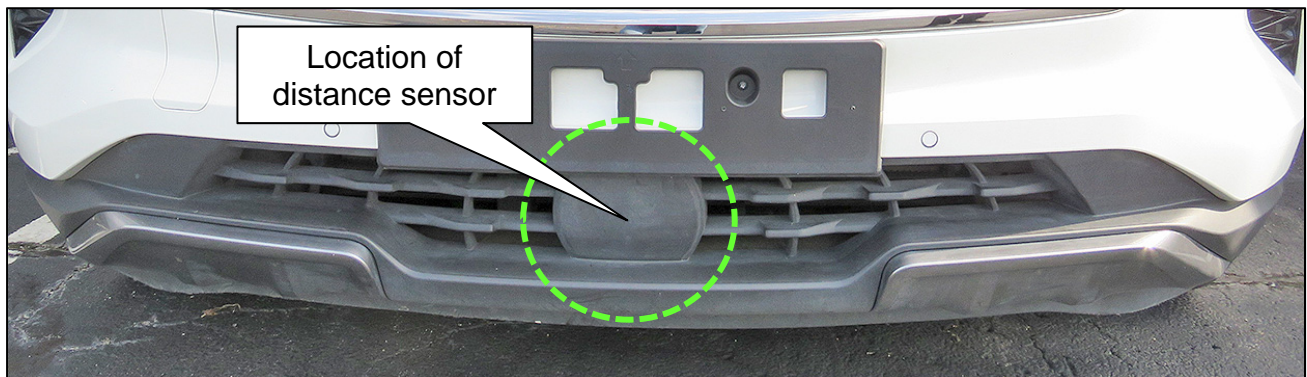
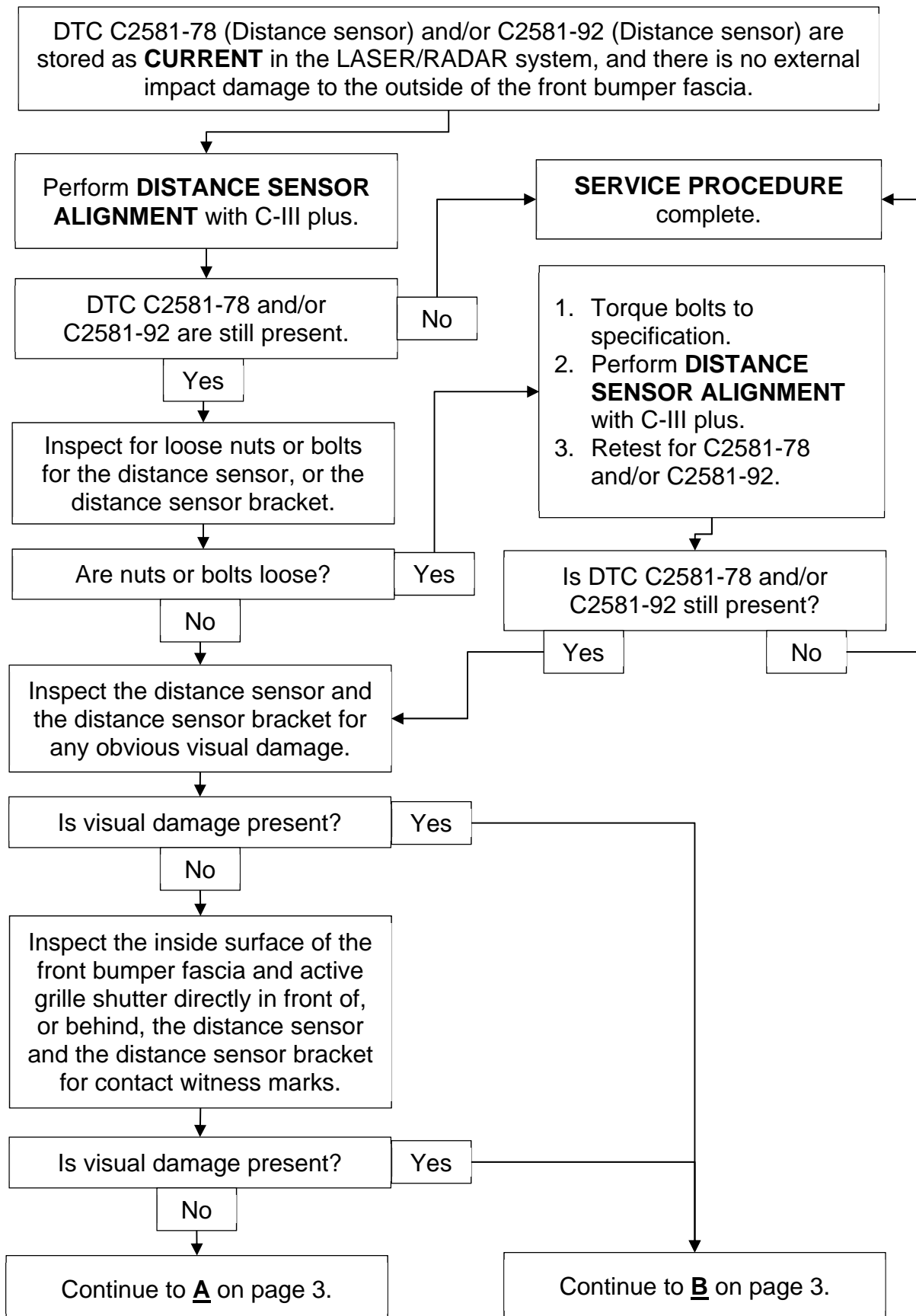

Figure 1

Bulletins are intended for use by qualified technicians, not 'do-it-yourselfers'. Qualified technicians are properly trained individuals who have the equipment, tools, safety instruction, and know-how to do a job properly and safely. **NOTE:** If you believe that a described condition may apply to a particular vehicle, DO NOT assume that it does. See your Infiniti retailer to determine if this applies to your vehicle.

Repair Overview



Repair Overview (continued)

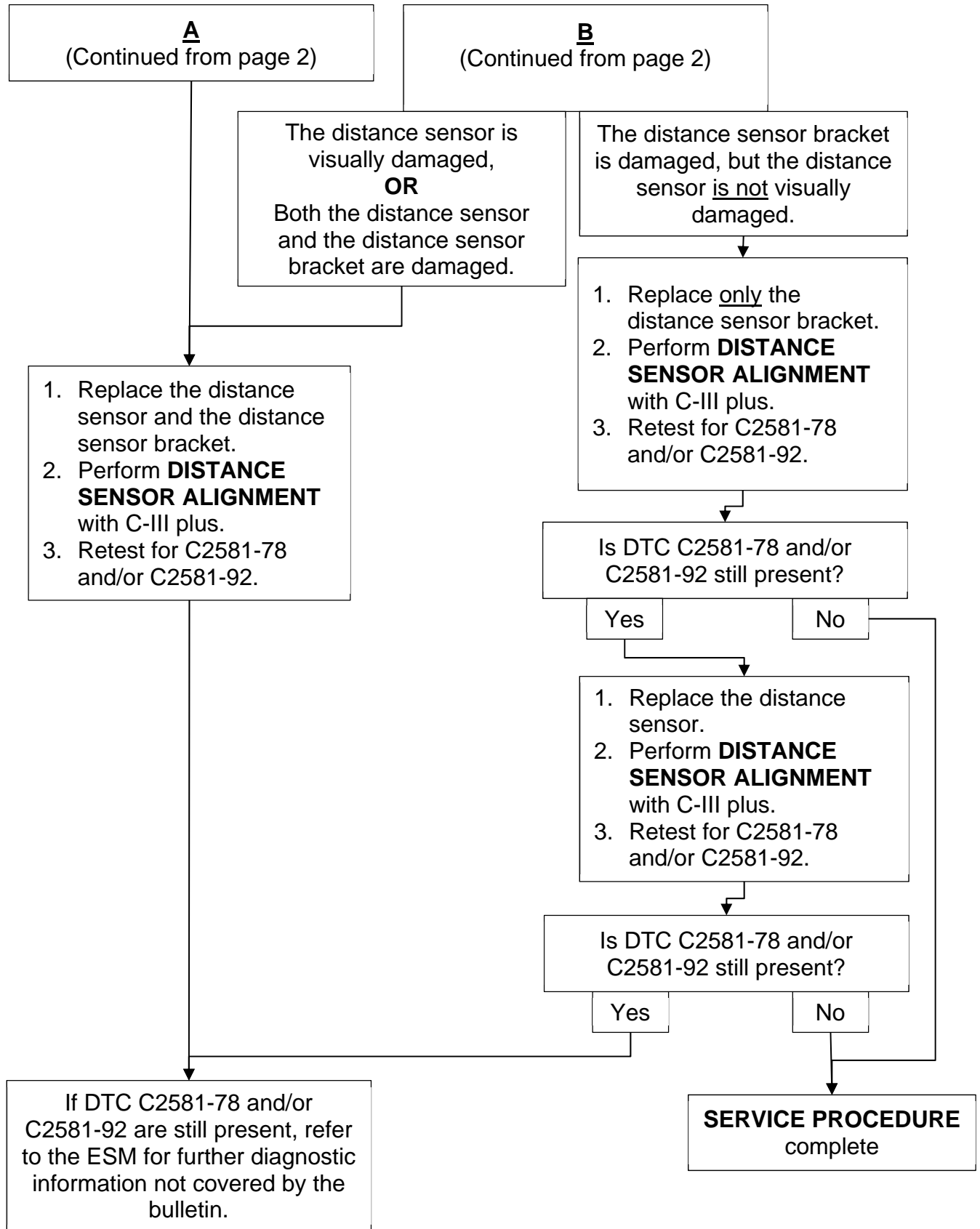

SERVICE PROCEDURE

Perform Distance Sensor Alignment and Retest

1. Perform **DISTANCE SENSOR ALIGNMENT** with C-III plus.
 - Refer to the ESM: **CRUISE CONTROL & DRIVER ASSISTANCE > DRIVER ASSISTANCE SYSTEM > DRIVER ASSISTANCE SYSTEM > BASIC INSPECTION > DISTANCE SENSOR ALIGNMENT**
 - a. Erase DTCs with C-III plus, and then recheck for DTCs.
 - If DTCs C2581-78 and/or C2581-92 are no longer present, the **SERVICE PROCEDURE** is complete.
 - If C2581-78 and/or C2581-92 are still present, proceed to step 2.

Inspection for Loose Nuts and/or Bolts

2. Remove the front bumper fascia.
 - Refer to the ESM: **BODY EXTERIOR, DOORS, ROOF & VEHICLE SECURITY > EXTERIOR > REMOVAL AND INSTALLATION > FRONT BUMPER**
3. Confirm if the distance sensor, or the distance sensor bracket, is noticeably loose.
 - If the distance sensor or the distance sensor bracket is not loose, proceed to step 4 on page 5.
 - If either the distance sensor or the distance sensor bracket is loose:
 - a. Tighten any loose nuts or bolts found attaching the distance sensor to the distance sensor bracket, or the distance sensor bracket to the vehicle, in the patterns shown in Figure 2 and Figure 3.
 - Distance sensor bracket bolt torque: 8.0 N•m (0.82 kg-m, **71 in.-lb**)
 - Distance sensor nut torque: 8.0 N•m (0.82 kg-m, **71 in.-lb**)

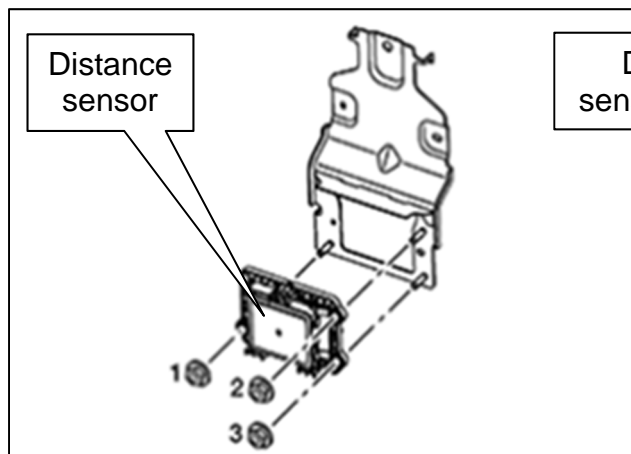

Figure 2

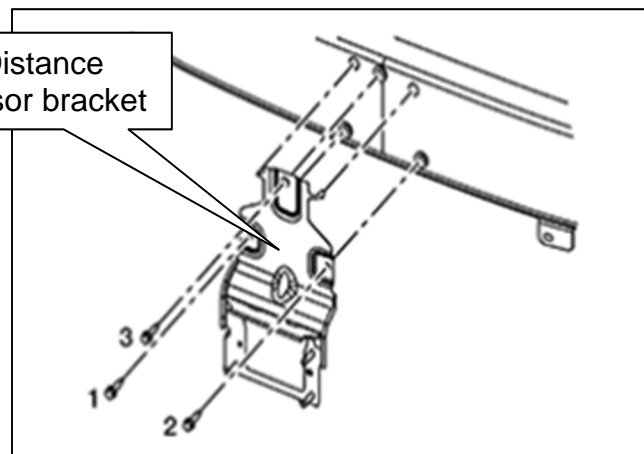

Figure 3

- b. Perform **DISTANCE SENSOR ALIGNMENT** with C-III plus.
 - Refer to the ESM: **CRUISE CONTROL & DRIVER ASSISTANCE > DRIVER ASSISTANCE SYSTEM > DRIVER ASSISTANCE SYSTEM > BASIC INSPECTION > DISTANCE SENSOR ALIGNMENT**
- c. Erase DTCs with C-III plus, and then recheck for DTCs.
 - If DTCs C2581-78 and/or C2581-92 are no longer present, reassemble the front bumper fascia. The **SERVICE PROCEDURE** is complete.
 - If C2581-78 and/or C2581-92 are still present, replace the distance sensor/ distance sensor bracket assembly, and then proceed to step 3d.
 - Refer to the ESM: **CRUISE CONTROL & DRIVER ASSISTANCE > DRIVER ASSISTANCE SYSTEM > DRIVER ASSISTANCE SYSTEM > REMOVAL AND INSTALLATION > DISTANCE SENSOR**
- d. Reassemble the front bumper fascia.
- e. Perform **DISTANCE SENSOR ALIGNMENT**, and then erase all DTCs with C-III plus. The **SERVICE PROCEDURE** is complete.
 - Refer to the ESM: **CRUISE CONTROL & DRIVER ASSISTANCE > DRIVER ASSISTANCE SYSTEM > DRIVER ASSISTANCE SYSTEM > BASIC INSPECTION > DISTANCE SENSOR ALIGNMENT**
 - If DTCs reoccur, refer to the ESM for further diagnostic information.

Inspection for Visual Damage to Distance Sensor or Distance Sensor Bracket

4. Inspect the distance sensor and the distance sensor bracket for any obvious visual damage, and then continue to page 7.

HINT: Minor impacts to the center of the front bumper fascia can bend the distance sensor bracket (Figure 5 and Figure 6 on page 6).

- Figure 4 is a side view of an undamaged distance sensor bracket. The front mounting surface should be parallel with vehicle mounting surfaces.

Undamaged distance sensor bracket, with all mounting surfaces parallel

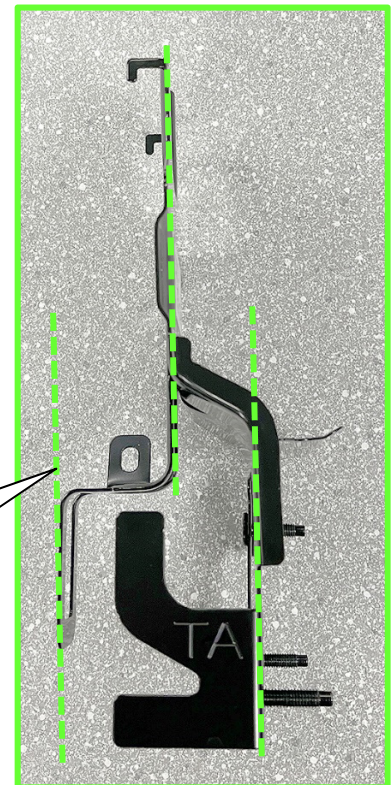

Figure 4

Unwarrantable Condition

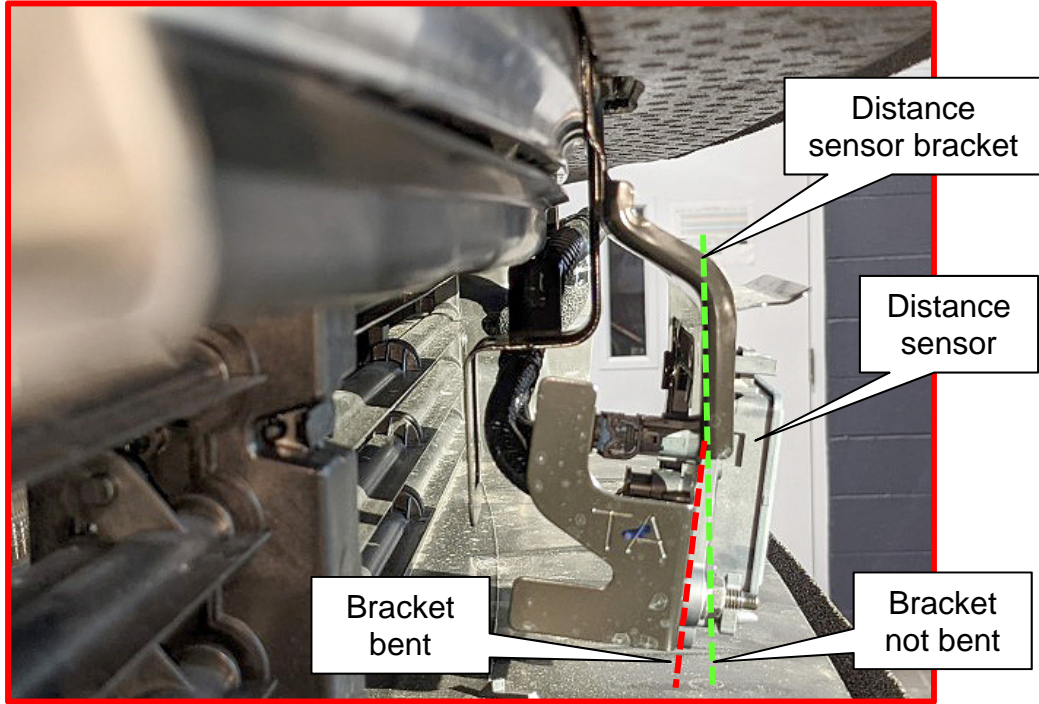

Figure 5

Damaged distance sensor brackets

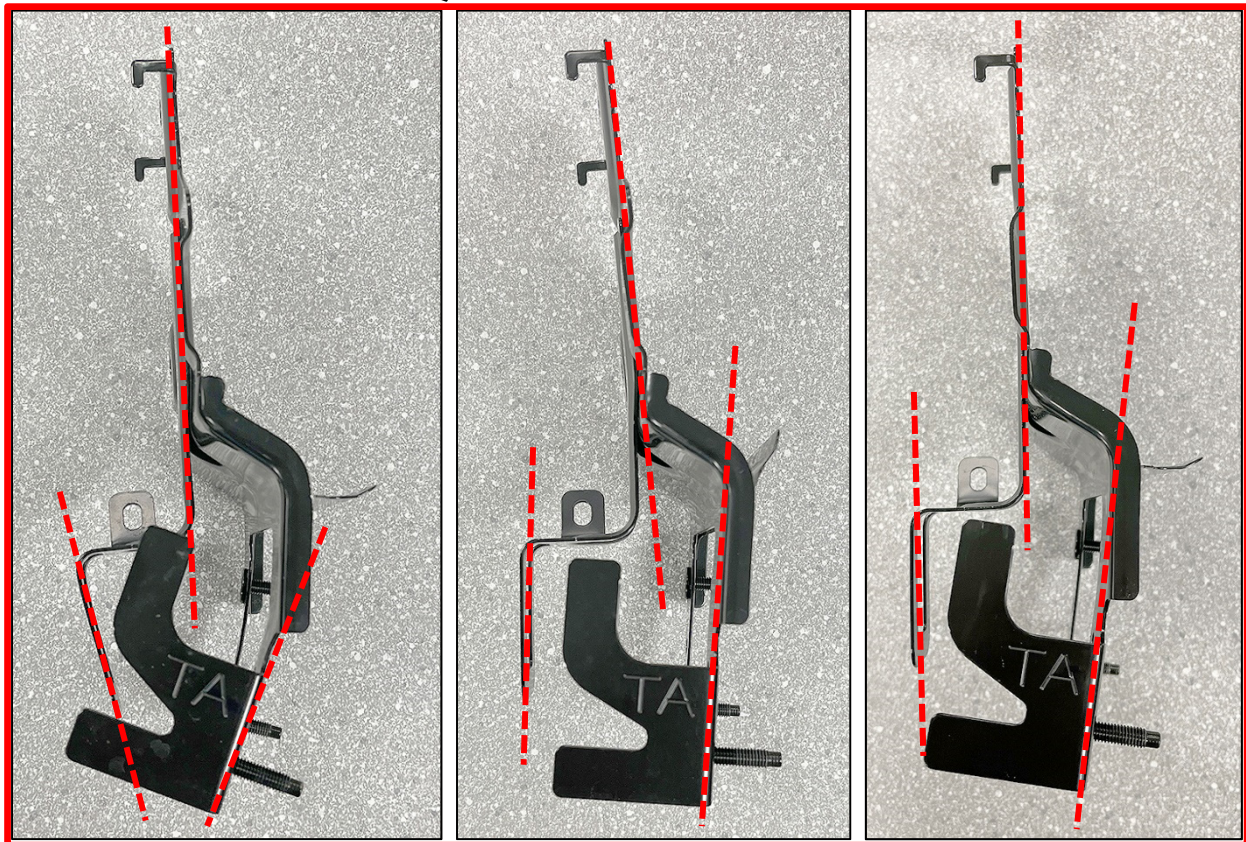

Figure 6

- If the distance sensor or the distance sensor bracket do not have obvious visual damage, proceed to step 5 on page 8.
- If either the distance sensor or the distance sensor bracket have obvious visual damage:
 - a. Make a note of the visual damage on the repair order.

IMPORTANT: Damage to the distance sensor and/or distance sensor bracket are an indication that the vehicle has come into contact with another object, and is not warrantable.
 - b. Replace the visually damaged component.
 - If the bracket appears bent, but there is no visual damage to the distance sensor, replace only the distance sensor bracket.
 - If the distance sensor has visual damage, replace it and the distance sensor bracket as an assembly.
 - Refer to the ESM: **CRUISE CONTROL & DRIVER ASSISTANCE > DRIVER ASSISTANCE SYSTEM > DRIVER ASSISTANCE SYSTEM > REMOVAL AND INSTALLATION > DISTANCE SENSOR**
 - c. Perform **DISTANCE SENSOR ALIGNMENT** with C-III plus.
 - Refer to the ESM: **CRUISE CONTROL & DRIVER ASSISTANCE > DRIVER ASSISTANCE SYSTEM > DRIVER ASSISTANCE SYSTEM > BASIC INSPECTION > DISTANCE SENSOR ALIGNMENT**
 - d. Erase DTCs with C-III plus, and then recheck for DTCs.
 - If DTCs C2581-78 and/or C2581-92 are no longer present, reassemble the front bumper fascia. The **SERVICE PROCEDURE** is complete.
 - If only the distance sensor bracket was replaced in step 4b and C2581-78 and/or C2581-92 are still present, replace the distance sensor, and then proceed to step 4e.
 - Refer to the ESM: **CRUISE CONTROL & DRIVER ASSISTANCE > DRIVER ASSISTANCE SYSTEM > DRIVER ASSISTANCE SYSTEM > REMOVAL AND INSTALLATION > DISTANCE SENSOR**
 - e. Reassemble the front bumper fascia.
 - f. Perform **DISTANCE SENSOR ALIGNMENT**, and then erase all DTCs with C-III plus. The **SERVICE PROCEDURE** is complete.
 - Refer to the ESM: **CRUISE CONTROL & DRIVER ASSISTANCE > DRIVER ASSISTANCE SYSTEM > DRIVER ASSISTANCE SYSTEM > BASIC INSPECTION > DISTANCE SENSOR ALIGNMENT**
 - If DTCs reoccur, refer to the ESM for further diagnostic information.

Inspection for Visual Damage to the Inside of the Front Bumper Fascia

5. Inspect the inside surface of the front bumper fascia and active grille shutter directly in front of, or behind, the distance sensor and the distance sensor bracket for contact witness marks (Figure 7 shown with front bumper fascia removed).

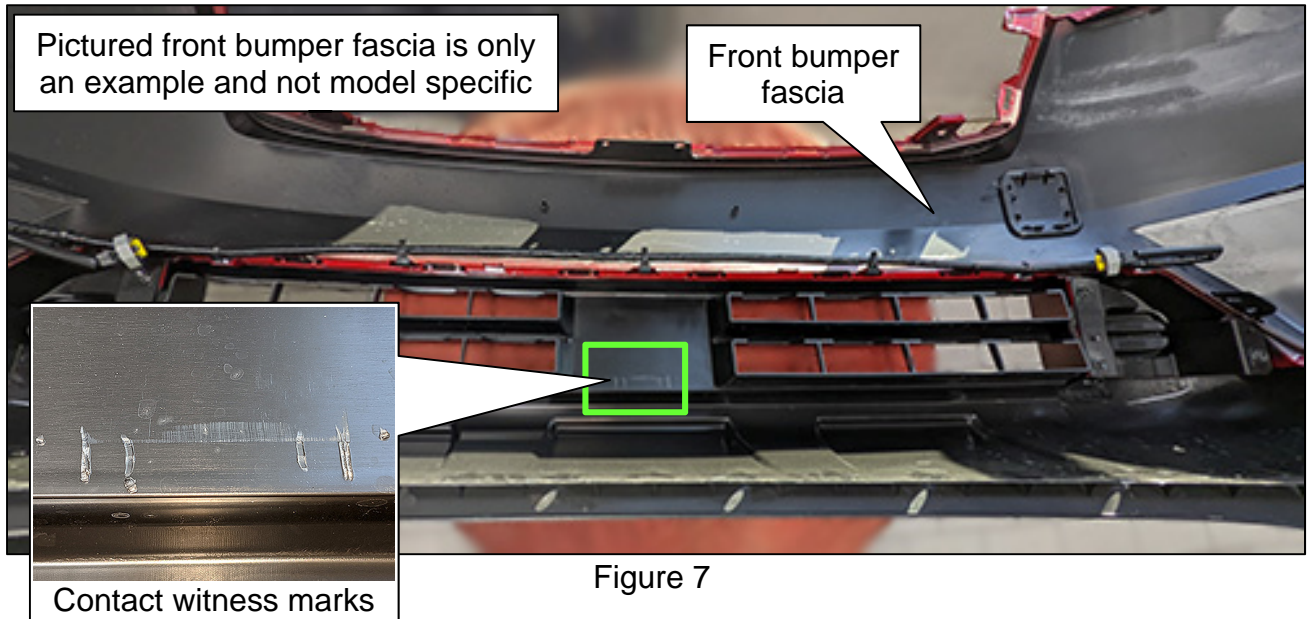
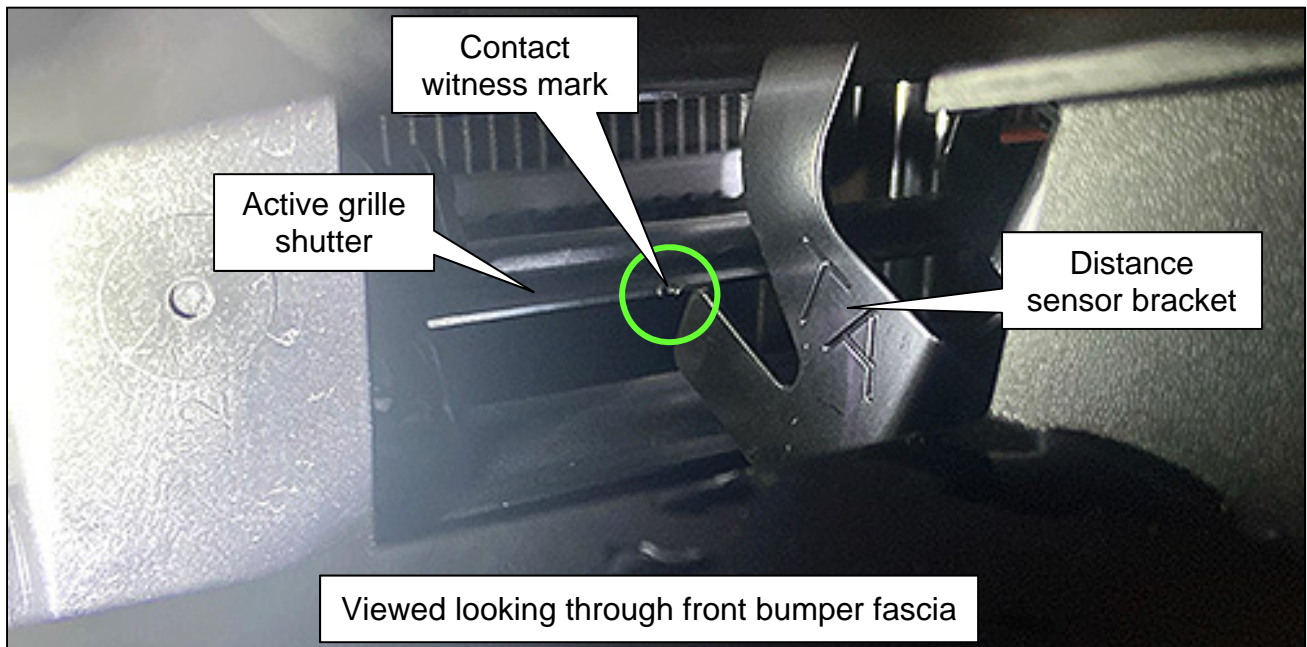

Figure 8 illustrates contact between the distance sensor bracket and the shutter grill.



- If contact witness marks are not present, proceed to step 6 on page 10.
- If contact witness marks are present:
 - a. Make a note of the witness marks on the repair order.

IMPORTANT: Witness marks on the inside of the bumper are an indication that the vehicle has come into contact with another object, and any damage to the distance sensor and/or the distance sensor bracket is not warrantable.
 - b. Replace the visually damaged component.
 - If the bracket appears bent, but there is no visual damage to the distance sensor, replace only the distance sensor bracket.
 - If the distance sensor has visual damage, replace it and the distance sensor bracket as an assembly.
 - Refer to the ESM: **CRUISE CONTROL & DRIVER ASSISTANCE > DRIVER ASSISTANCE SYSTEM > DRIVER ASSISTANCE SYSTEM > REMOVAL AND INSTALLATION > DISTANCE SENSOR**
 - c. Perform **DISTANCE SENSOR ALIGNMENT** with C-III plus.
 - Refer to the ESM: **CRUISE CONTROL & DRIVER ASSISTANCE > DRIVER ASSISTANCE SYSTEM > DRIVER ASSISTANCE SYSTEM > BASIC INSPECTION > DISTANCE SENSOR ALIGNMENT**
 - d. Erase DTCs with C-III plus, and then recheck for DTCs.
 - If DTCs C2581-78 and/or C2581-92 are no longer present, reassemble the front bumper fascia. The **SERVICE PROCEDURE** is complete.
 - If only the distance sensor bracket was replaced in step 5b and C2581-78 and/or C2581-92 are still present, replace the distance sensor, and then proceed to step 5e.
 - Refer to the ESM: **CRUISE CONTROL & DRIVER ASSISTANCE > DRIVER ASSISTANCE SYSTEM > DRIVER ASSISTANCE SYSTEM > REMOVAL AND INSTALLATION > DISTANCE SENSOR**
 - e. Reassemble the front bumper fascia.

Perform **DISTANCE SENSOR ALIGNMENT**, and then erase all DTCSs with C-III plus. The **SERVICE PROCEDURE** is complete.

 - Refer to the ESM: **CRUISE CONTROL & DRIVER ASSISTANCE > DRIVER ASSISTANCE SYSTEM > DRIVER ASSISTANCE SYSTEM > BASIC INSPECTION > DISTANCE SENSOR ALIGNMENT**
 - If DTCs reoccur, refer to the ESM for further diagnostic information.

6. Replace both the distance sensor and the distance sensor bracket.
 - a. Replace the distance sensor and the distance sensor bracket.
 - o Refer to the ESM: **CRUISE CONTROL & DRIVER ASSISTANCE > DRIVER ASSISTANCE SYSTEM > DRIVER ASSISTANCE SYSTEM > REMOVAL AND INSTALLATION > DISTANCE SENSOR**
 - b. Perform **DISTANCE SENSOR ALIGNMENT** with C-III plus.
 - o Refer to the ESM: **CRUISE CONTROL & DRIVER ASSISTANCE > DRIVER ASSISTANCE SYSTEM > DRIVER ASSISTANCE SYSTEM > BASIC INSPECTION > DISTANCE SENSOR ALIGNMENT**
 - c. Erase DTCs with C-III plus, and then recheck for DTCs.
 - o If DTCs C2581-78 and/or C2581-92 are no longer present, reassemble the front bumper fascia. The **SERVICE PROCEDURE** is complete.
 - o If DTCs reoccur, refer to the ESM for further diagnostic information.

PARTS INFORMATION

DESCRIPTION	PART NUMBER	QUANTITY
SENSOR (Distance sensor)	28437-6RU8A	1 As needed
BRACKET DISTANCE SENSOR	28452 6SA3A	1 As needed

CLAIMS INFORMATION

Submit a Primary Part (PO) type line claim using the following claims coding:

DESCRIPTION	OP CODE	SYM	DIA	FRT
Perform Distance Sensor Alignment	WH26AA	ZE	32	(1)

NOTE: Adjustment Coverage Period is 12 Months/ 12,000 Miles.

OR, If codes are still present inspect for loose bolts and impact marks

Submit a Primary Part (PP) type line claim using the following claims coding:

DESCRIPTION	PFP	OP CODE	SYM	DIA	FRT
Inspect Distance Sensor and Bracket without AVM (No Damage Found)	(2)	RXC5AA	ZE	32	1.8
Inspect Distance Sensor and Bracket with AVM (No Damage Found)		RXC6AA			2.2
Perform Distance Sensor Alignment		WH26AA			(1)

NOTE: Damage as a result of impact is not warrantable

And if needed

DESCRIPTION	PFP	OP CODE	SYM	DIA	FRT
Replace Distance Bracket and/or Sensor	(2)	RD45AA	ZE	32	(1)

- (1) Reference the current Nissan Warranty Flat Rate Manual and use the indicated Flat Rate Time (FRT).
- (2) Reference the electronic parts catalog and use the Distance Sensor Brackett (24852-*****) as the Primary Failed Part (PFP).

NOTE: Distance Sensor and Brackets replaced under warranty will be collected for inspection. The warranty claim will be subject to chargeback if failure was deemed impact related.

AMENDMENT HISTORY

PUBLISHED DATE	REFERENCE	DESCRIPTION
November 4, 2022	ITB22-037	Original bulletin published

