



INSTRUCTION TO SERVICE

ITS60523		September 27, 2022
SECTION:	260-BATTERY COMPARTMENT	
WRITTEN BY:	Ilan Kizner	
SUBJECT:	Rework – Incorrect orientation for the DC charge box contactors	
ISSUE:	Failing DC Contactors	
SUMMARY:	Incorrect orientation of the DC contactors could potentially contribute to premature contactor failure	

ITS60523

Ref. NHTSA Recall No.	Ref. Transport Canada Recall No.
Not Applicable	Not Applicable

THIS ITS DOCUMENT SHOULD BE RETAINED AND REFERRED TO FOR FUTURE MAINTENANCE UNTIL THE NEW FLYER PARTS AND/OR SERVICE MANUAL IS UPDATED TO REFLECT WORK DONE AS A RESULT OF THIS DOCUMENT. ENSURE THAT THIS DOCUMENT IS AVAILABLE FOR PARTS AND MAINTENANCE STAFF GOING FORWARD.



Contents

1. SAFETY PROCEDURE.....	3
2. REWORK PROCEDURE – charge boxes 731337, 791515, 774952, 824163, 859824	4
4. REWORK PROCEDURE – charge box 835762.....	6

⚠ WARNING: Only trained personnel shall supervise and perform High Voltage system testing, checkout and troubleshooting. Two personnel (one called the Checker & the other called Monitor/Recorder) shall perform Checkout Procedures, together, to ensure safety of themselves, others nearby & for the protection of vehicle & property. Refresher training shall be provided to these personnel on a regular basis and when new systems are to be checked by them. The training of the personnel shall consist of:

1. SAFETY PROCEDURE

- 1.1. Turn the master run switch to the off position and wait 5 minutes before proceeding.
- 1.2. Turn the 12/24V battery disconnect and HV Interlock switch to the "OFF" position.
- 1.3. Lock and Tag the electrical system of the bus out and retain the key. See Figure 1.
- 1.4. Install a Lockout/Tagout Steering wheel cover as require

👉 NOTE: Refer to the Lockout/Tagout Procedure in section 1 of your Preventive Maintenance Manual or section 9 of your Service manual for additional information.

👉 NOTE: Use commercially available lock out equipment and tags being sure to follow any local laws or workplace procedures.

👉 NOTE: Refer to New Flyer High Voltage Safety Guidelines and Procedures Document 532295 when completing installation or service work on high voltage power cables.

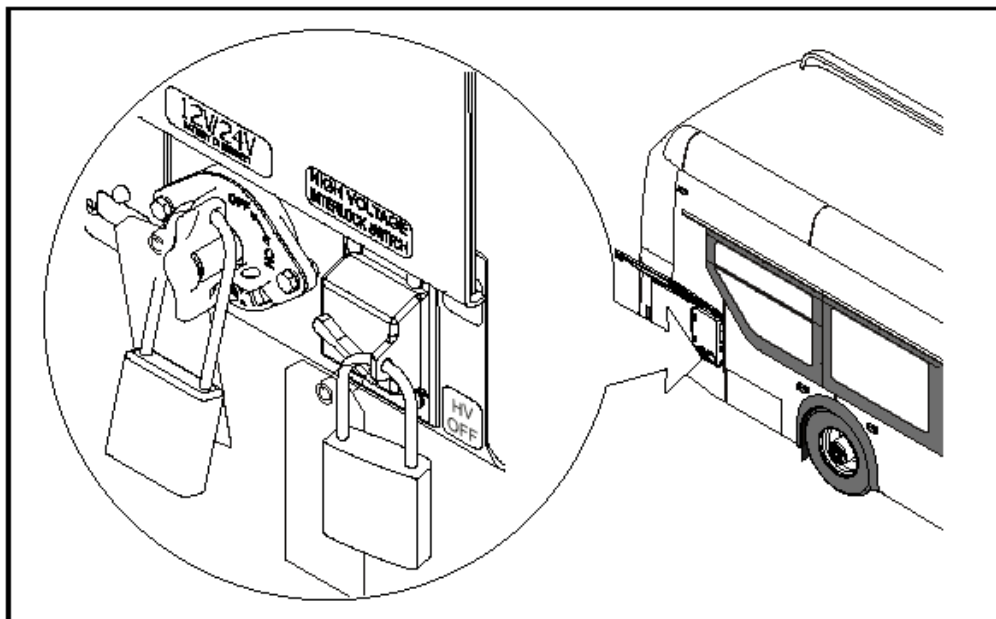
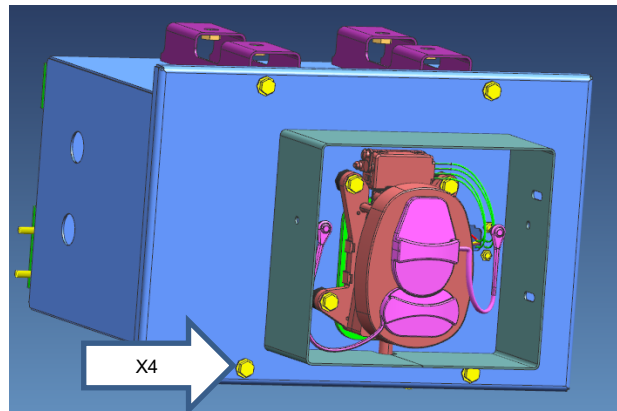

Figure 1: Lockout tagout location reference

NOTE: please verify the charge box Part Number before starting the rework, the manual below will describe the rework procedure for each type of charge box.

2. REWORK PROCEDURE – charge boxes 731337, 791515, 774952, 824163, 859824



- 2.1. Locate charge box
- 2.2. Unscrew the 4 screws holding the front cover and remove the front cover.
- 2.3. Make sure that both contactors are oriented in the correct position according to Figure 2. The positive receptacle cable should connect to (A1+) of the positive contactor and (A2-) of the positive contactor should connect to cable going to the ESS system. The negative receptacle cable should connect to (A2-) of the negative contactor and (A1+) of the negative contactor should connect to the cable coming back from the ESS.

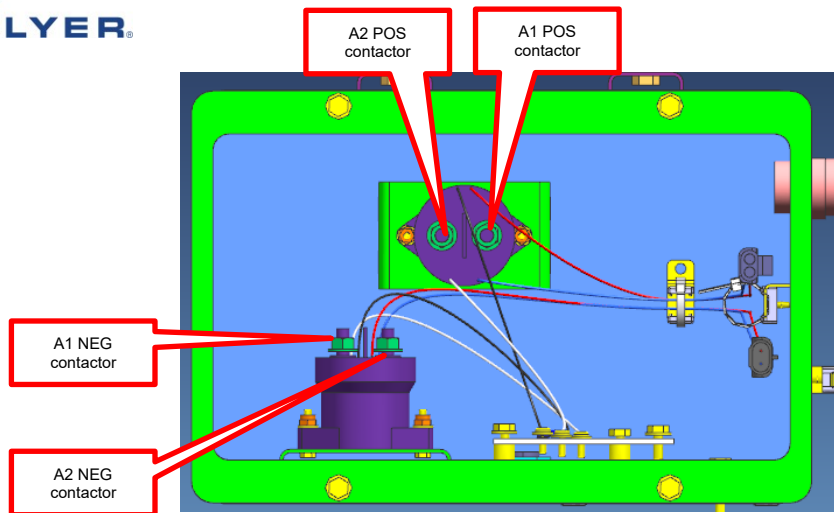

Figure 1 - Box 731337 with correct contactor orientation

3. Rotate charge box contactor

- 3.1. In case the contactors are mounted incorrectly, disconnect the contactor low voltage signal plugs.
- 3.2. Remove the positive and negative cables from terminals A1 and A2 of each contactor.
- 3.3. Open the M8x1.25 flanged nuts and retain hardware.
- 3.4. Unscrew the two contactor mounting Phillips screws, retain hardware and remove the contactor.
- 3.5. Install contactor in the correct orientation and secure with two mounting Philips screws. (use torque 22 IN-LBS, DRY). Connect the HV cable ring terminal to the contactor studs as shown in the figure 2 (use torque 90 IN-LBS).
- 3.6. Reconnect low voltage signal plugs.
- 3.7. Secure harnesses inside the box using tie base.
- 3.8. Close front cover and secure using 4 screws. Torque screws to 6 FT-LBS.

4. REWORK PROCEDURE – charge box 835762

- 4.1. Locate charge box
- 4.2. Unscrew the 4 screws holding the front cover and remove the front cover.
- 4.3. Make sure that both contactors are oriented in the correct position according to Figure 3. The positive receptacle cable should connect to (A1+) of the positive contactor and (A2-) of the positive contactor should connect to cable going to the ESS system. The negative receptacle cable should connect to (A2-) of the negative contactor and (A1+) of the negative contactor should connect to the cable coming back from the ESS.

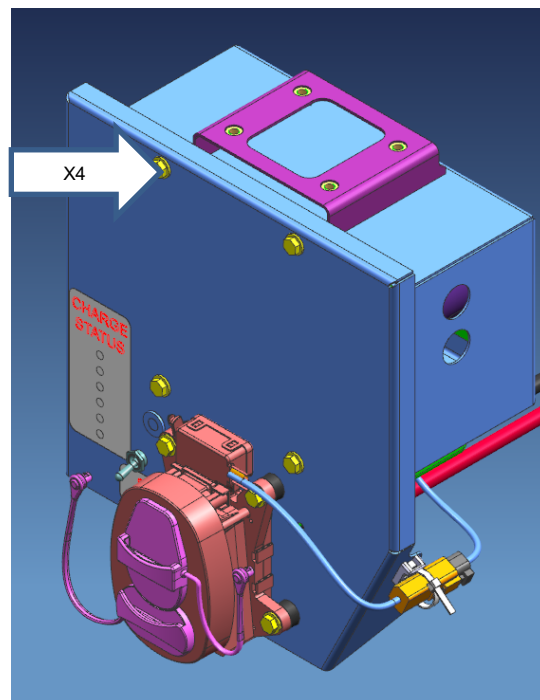

5. Rotate charge box contactor

- 5.1. In case the contactors are mounted incorrectly, disconnect the contactor low voltage signal plugs.
- 5.2. Remove the positive and negative cables from terminals A1 and A2 of each contactor.
- 5.3. Open the M8x1.25 flanged nuts and retain hardware.
- 5.4. Unscrew the two contactor mounting Phillips screws, retain hardware and remove the contactor.
- 5.5. Install contactor in the correct orientation and secure with two mounting Philips screws.
(use torque 22 IN-LBS, DRY).
- 5.6. Connect the HV cable ring terminal to the contactor studs as shown in the figure 3
(use torque 90 IN-LBS).
- 5.7. Reconnect low voltage signal plugs.
- 5.8. Secure harnesses inside the box using tie base.

5.9. Close front cover and secure using 4 screws. Torque screws to 6 FT-LBS.

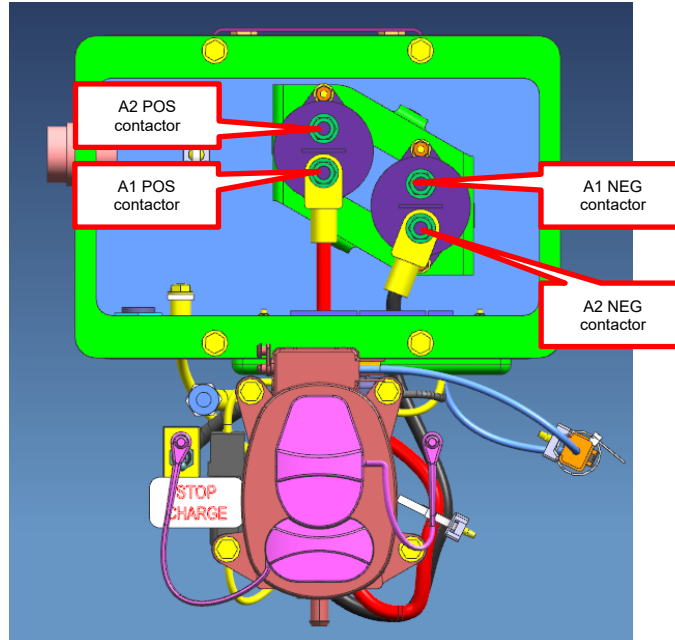

Figure 3 - Box 790772 with correct contactor orientation



LABOUR ESTIMATE				
	Operation	Number of Technician(s)	Hours	Labor Time T X HR
1		1	2	2

PARTS REQUIRED					
Item	Part Number	Description	Qty. per Coach	Units	Notes
1	706989	ASSY-CONTACTOR GIGAVAC NEG	1	EA	
2	706986	ASSY-CONTACTOR GIGAVAC POS	1	EA	

SPECIAL TOOLS REQUIRED					
Item	Part Number	Description	Qty.	Units	Notes
1					