

Service Alert

Mazda North American Operations
Irvine, CA 92618-2922



Subject: ATF-FZ REQUIRED FOR SKYACTIV DRIVE 6-SPEED AUTOMATIC TRANSAXLE	Service Alert No.: SA-068/22
	Last Issued : 10/17/2022

BULLETIN NOTES

This Service Alert supersedes the previously issued bulletin(s) listed below. The changes are noted below in Red.

Previously Issued TSBs:	Date(s) issued
05-002/18	04/02/18
05-002/16	01/25/16
05-003/13	03/04/13
05-007/11	09/21/11

APPLICABLE MODEL(S)/VINS

2016-2023 Mazda2	2016-2023 CX-3	2012-2013 Mazda3 (SKYACTIV)
2013-2023 CX-5	2016-2023 CX-9	2023 Mazda3 (2.5 without cylinder deactivation and 2.5T)
2014-2022 Mazda3	2020-2022 CX-30	2023 CX-30 (2.5 without cylinder deactivation and 2.5T)
2014-2021 Mazda6		

DESCRIPTION

The new SKYACTIV-DRIVE FW6A-EL AT uses "Automatic Transmission Fluid (ATF) Type: FZ". Only use "ATF-FZ" to fill or top off the fluid level. ATF-FZ is specially designed for use in the SKYACTIV-DRIVE series AT. It is a low viscosity formula with less friction for better fuel economy.

NOTE: ATF-FZ is colored blue for easy identification.

CONSUMER NOTICE: The information and instructions in this bulletin are intended for use by skilled technicians. Mazda technicians utilize the proper tools/ equipment and take training to correctly and safely maintain Mazda vehicles. These instructions should not be performed by "do-it-yourselfers." Customers should not assume this bulletin applies to their vehicle or that their vehicle will develop the described concern. To determine if the information applies, customers should contact their nearest authorized Mazda dealership. Mazda North American Operations reserves the right to alter the specifications and contents of this bulletin without obligation or advance notice. All rights reserved. No part of this bulletin may be reproduced in any form or by any means, electronic or mechanical---including photocopying and recording and the use of any kind of information storage and retrieval system ---without permission in writing.

To check the fluid level, remove the bolt, then remove the dipstick. The dipstick is marked with a "FZ" on SKYACTIV-DRIVE FW6A-EL AT. When finished, insert the dipstick and install the bolt.

Tightening torque: 8-10 N·m (82-101 kgf·cm, 71-88 in·lbf)

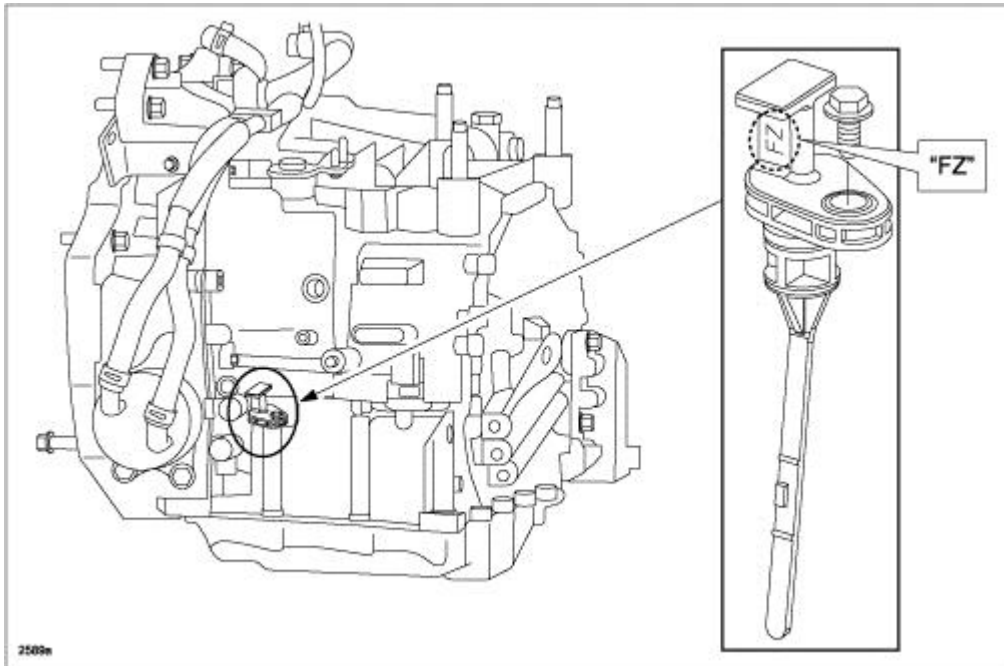

The fluid level should be between the (1) and (2) when the ATF is warm (at least 50 °C (122 °F)).

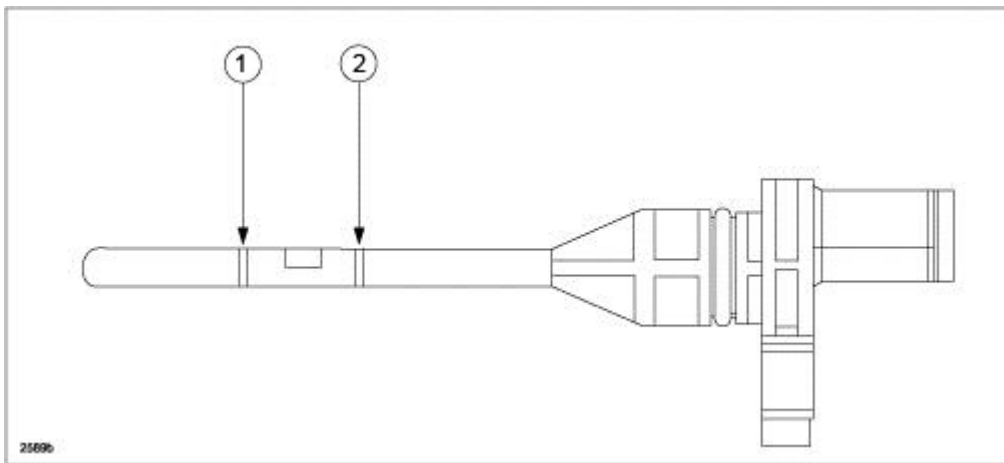

SKYACTIV-DRIVE FW6A-EL AT with "ATF-FZ" is "filled for life" (no change intervals for ATF required) and flushing is not recommended as part of service maintenance. There are no oil cooler lines and the replacement SKYACTIV-DRIVE FW6A-EL AT will come with a new oil cooler, which is mounted directly to the case. If repair or AT replacement is necessary, use only "ATF-FZ" to fill the AT.

CONSUMER NOTICE: The information and instructions in this bulletin are intended for use by skilled technicians. Mazda technicians utilize the proper tools/ equipment and take training to correctly and safely maintain Mazda vehicles. These instructions should not be performed by "do-it-yourselfers." Customers should not assume this bulletin applies to their vehicle or that their vehicle will develop the described concern. To determine if the information applies, customers should contact their nearest authorized Mazda dealership. Mazda North American Operations reserves the right to alter the specifications and contents of this bulletin without obligation or advance notice. All rights reserved. No part of this bulletin may be reproduced in any form or by any means, electronic or mechanical--including photocopying and recording and the use of any kind of information storage and retrieval system ---without permission in writing.

CAUTION:

- ATF-FZ is designed ONLY FOR SKYACTIV-DRIVE series AT.
- If an ATF other than “ATF-FZ” is used in the SKYACTIV-DRIVE AT, the performance and reliability cannot be guaranteed. The resulting damage will not be covered by warranty.
- Use of ATF-FZ in non SKYACTIV-DRIVE ATs may result in serious internal damage that will not be covered by warranty

PARTS INFORMATION

Description	Part Number	Qty.	Notes
ATF-FZ	0000-FZ-113E-01	1 quart	Available in 4 pack or 12 pack



CONSUMER NOTICE: The information and instructions in this bulletin are intended for use by skilled technicians. Mazda technicians utilize the proper tools/ equipment and take training to correctly and safely maintain Mazda vehicles. These instructions should not be performed by “do-it-yourselfers.” Customers should not assume this bulletin applies to their vehicle or that their vehicle will develop the described concern. To determine if the information applies, customers should contact their nearest authorized Mazda dealership. Mazda North American Operations reserves the right to alter the specifications and contents of this bulletin without obligation or advance notice. All rights reserved. No part of this bulletin may be reproduced in any form or by any means, electronic or mechanical—including photocopying and recording and the use of any kind of information storage and retrieval system ---without permission in writing.