

# 13L Oil Pickup Replacement

**Service Category** Service Department

**Section** Function Group 254

**Technician Skill Level** A

**Market** North America

**Applicability**

**VOLVO**

Years	Models
2022 - 2023	VN, VHD

**Introduction**

Volvo trucks has determined the certain VN and VHD model truck with a D-13 could have a defective oil pick-up strainer. On effected vehicles follow the instructions below to.

1. Replace the oil pick-up strainer with new one.
2. Replace both oil filters and engine oil.

**Production Change Information**

This bulletin applies to vehicles built within the specified production changes below.

Brand	Engine	Emission Level	Starting Build Date	Ending Build Date
Volvo	D13	EM-USA21	20-January-2021	19-January-2022

**Warranty Information**

<b>This repair is covered by an authorized Service Program. Reimbursement is obtained through the normal claim handling process.</b>			<b>B</b>
Main Labor Code	Description	Hours	
2211-03-02-03	Pickup Tube, Oil Pump, Replacement	1.7	
Causal Part	20824910		
SCC Authorization Code	S7645		
Expiration Date	May 31, 2023		

## 13L Oil Pickup Replacement

---

### Parts Information

Part Numbers	Part Names	Quantity
23545374	Oil strainer	1
20541940	Oil pan gasket	1
22275838	Sealing Ring	2
21780376	Sealing Ring	1
949656	Sealing Ring	1
23151592	Oil filters	2
Volvo Approved Oil	Engine oil	*

### Calibration Information

### Repair Procedure

1. Secure the vehicle for service by parking it on a level surface, applying the parking brake, blocking the wheels, and placing the transmission in neutral or park.
2. Disconnect all cables from the negative (ground) battery terminals to prevent personal injury from electrical shock and prevent damage to electrical components.
3. Unlatch and raise the hood.

## 13L Oil Pickup Replacement

---

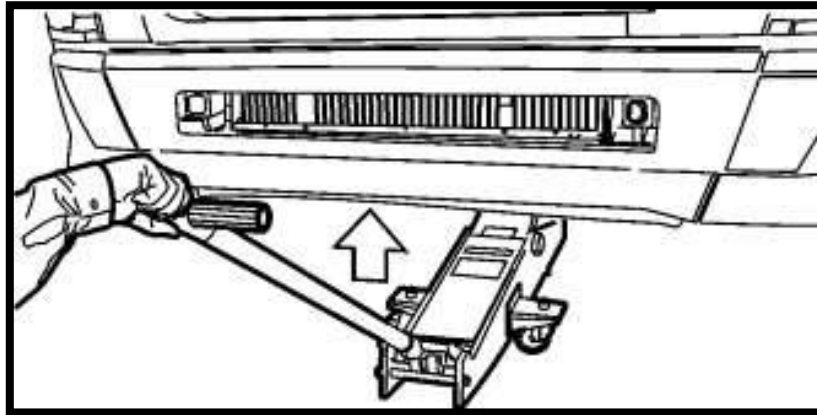

4. Using a hydraulic jack, lift the front axle until the front wheels are off the ground. Position jack stands of a suitable capacity under the frame in a position which will allow the front axle to hang free.

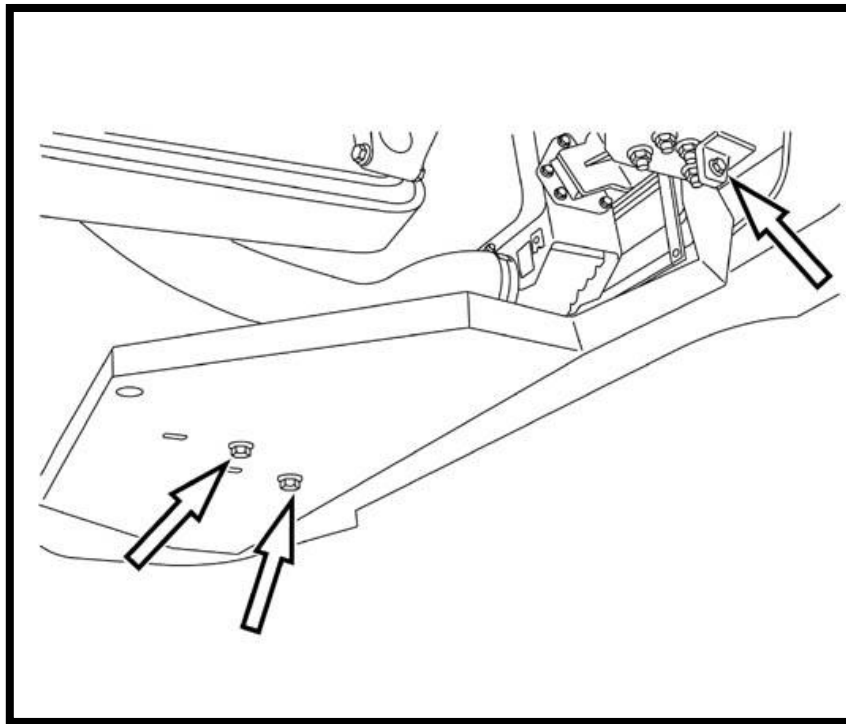

5. If required, remove the skid plate to allow access for oil pan removal.
6. Place an approved container under the oil pan. Drain the oil by removing the drain plug.

## 13L Oil Pickup Replacement

---

Note
Use only hand tools when removing and installing the drain plug. Do not use an air ratchet or similar air tool.

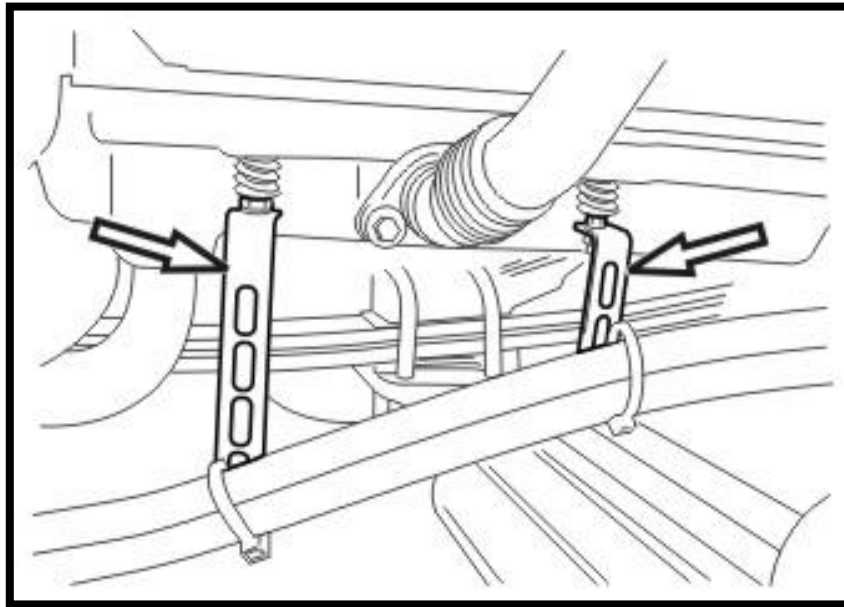

7. Remove the transmission cooler and power steering line brackets. Separate the brackets from the oil pan fasteners. Position the cooler lines out of the way.

Note
Mark the transmission cooler and power steering line bracket stud locations to aid in reassembly.

8. Pull the dipstick partially out of the dipstick tube. Remove the dipstick tube fastener and tube from the oil pan. Remove and discard the O-ring.

## 13L Oil Pickup Replacement

---

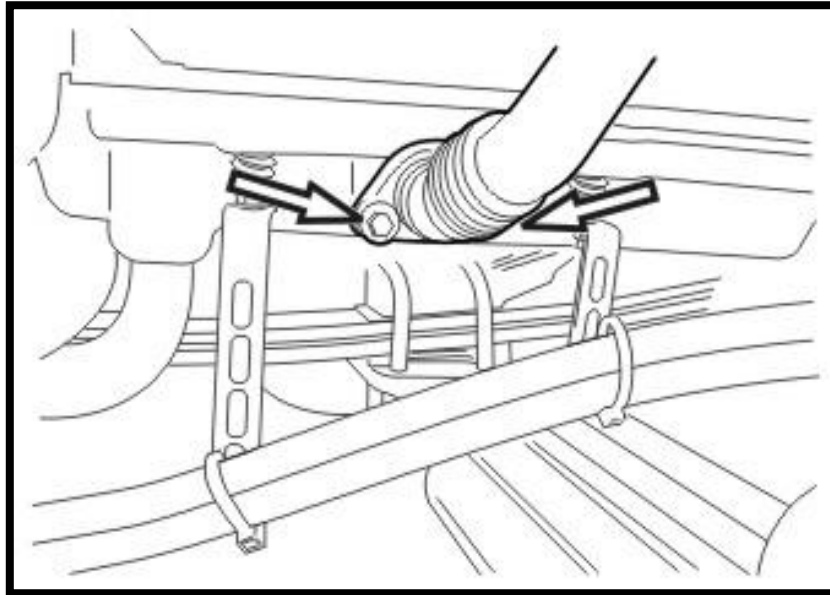

9. Remove the oil fill tube fasteners and tube from the oil pan. Remove and discard the tube O-ring.

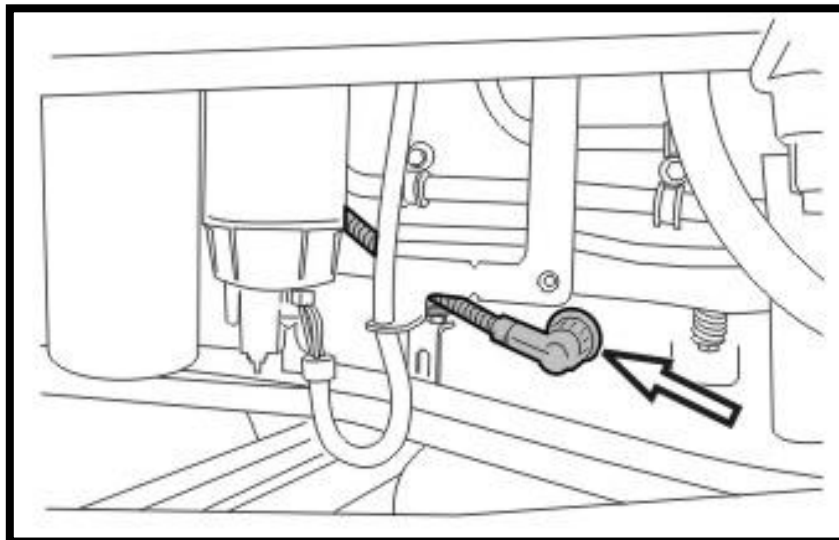

10. Disconnect the engine oil level/temperature sensor connector.

## 13L Oil Pickup Replacement

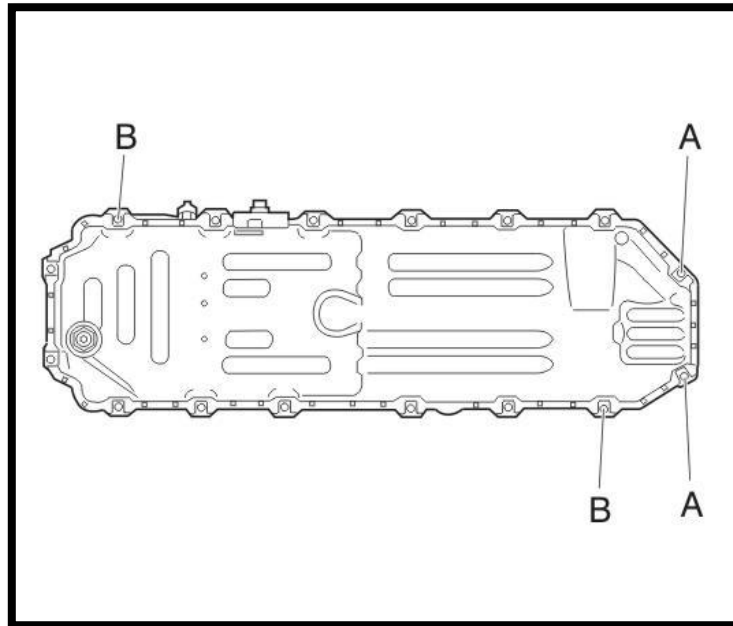

11. Remove the fasteners marked A. Loosen the fasteners marked B, but do not remove. Remove all the other fasteners.
12. With assistance, remove the remaining fasteners (B) and carefully lower and remove the oil pan.

Note
Be careful while removing the oil pan not to hit the pickup tube.

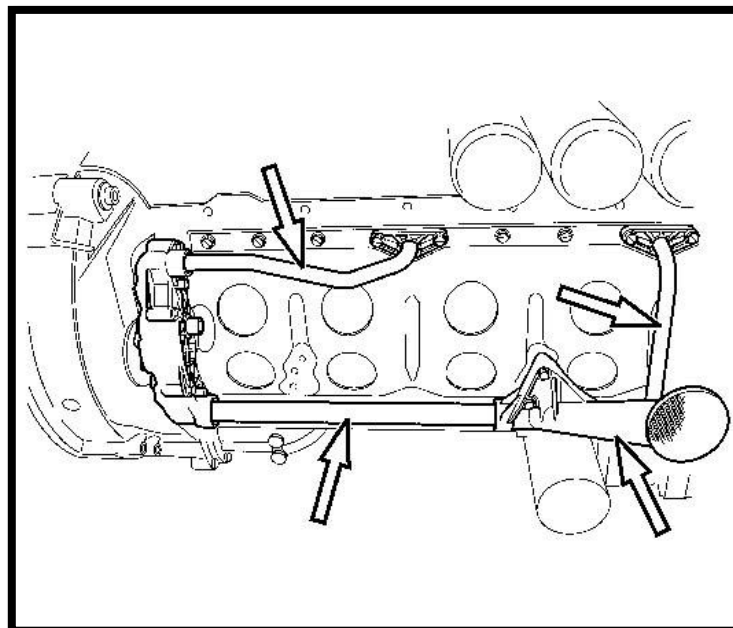

## 13L Oil Pickup Replacement

---

13. Loosen and remove the fasteners securing the oil strainer to the engine stiffening frame. Remove the oil strainer and pickup (suction) tube. Slide the tube out of the oil pump.
14. Separate the oil suction pipe from the oil strainer.
15. Replace both O-rings on the oil suction pipe and install new oil strainer (23545374) onto the pipe.
16. Slide the oil pickup pipe into the oil pump, position the oil strainer to the engine stiffening frame, install the fasteners and tighten to specification.

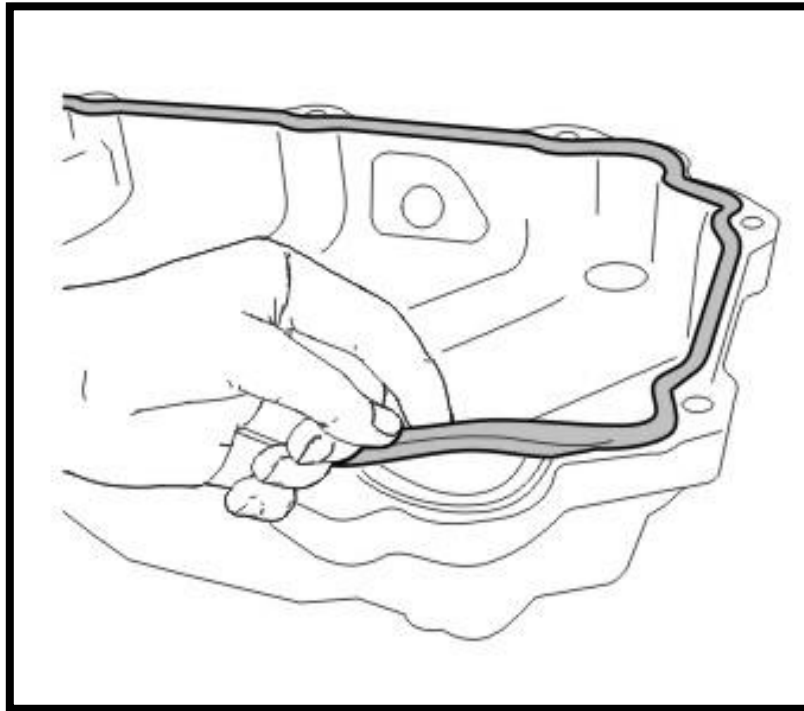

17. Remove the rubber gasket from the oil pan. Clean the oil pan and contact surface on the cylinder block, flywheel housing and front seal cover. All surfaces must be completely free of any grease or oil residue.

## 13L Oil Pickup Replacement

---

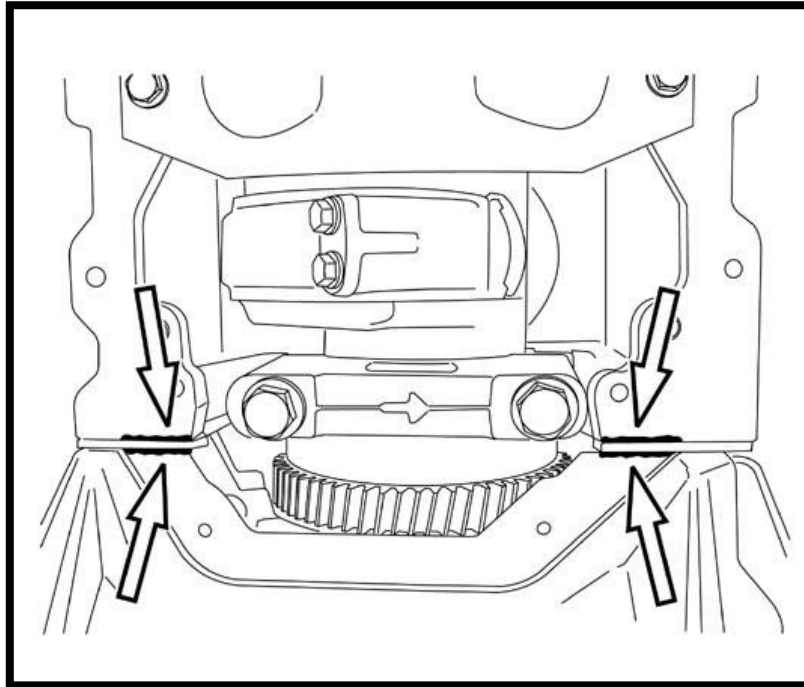

18. Apply a 2 mm (0.079 in) bead of approved sealant to the seams between the flywheel housing and the timing gear mounting plate and between the timing gear mounting plate and the cylinder block.

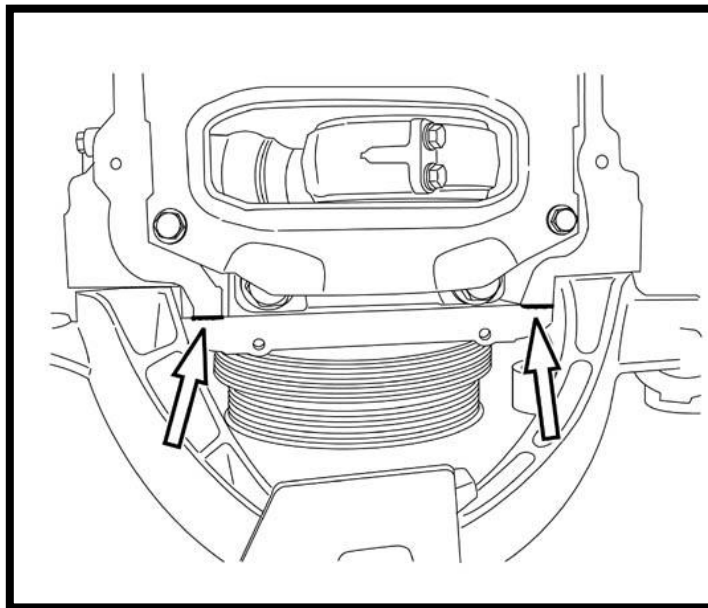

19. Apply a two mm (0.079 inch) bead of approved sealant to the seam between the front seal cover and the cylinder block.

## 13L Oil Pickup Replacement

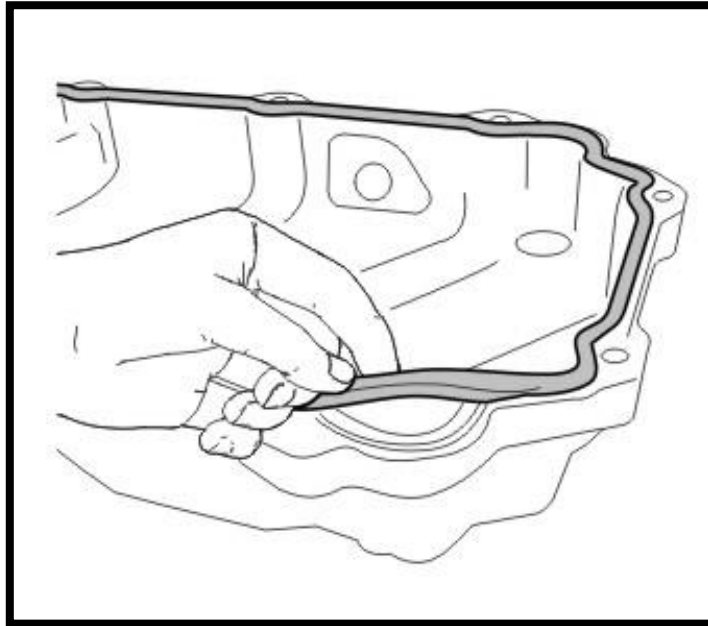

20. Position a new rubber gasket on the oil pan.

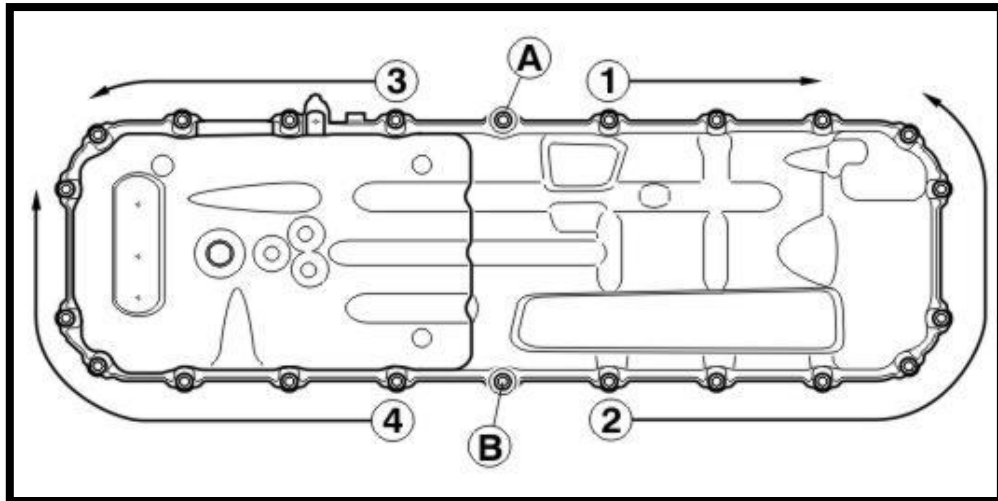

21. With assistance, position the oil pan to the engine block and install the two fasteners marked A and B, tighten to specification.

Tightening torque	
Oil pan (steel and plastic)	24 ± 4 Nm (18 ± 3 ft-lb)
Drain plug, oil pan (steel and plastic)	60 ± 10 Nm (44 ± 7 ft-lb)

Note

## 13L Oil Pickup Replacement

---

Use care to avoid damaging the oil pickup.

22. Tighten the fasteners from the middle and outwards in order 1–4 as shown. Tighten the fasteners to specification. Finish by checking the torque for fasteners A and B.
23. Install the oil drain plug and tighten to specification.

**Note**

The drain plug must not be installed with a copper washer. Always use the steel washer.

**Note**

Do not use an air impact ratchet or similar air tool to remove or install the oil drain plug.

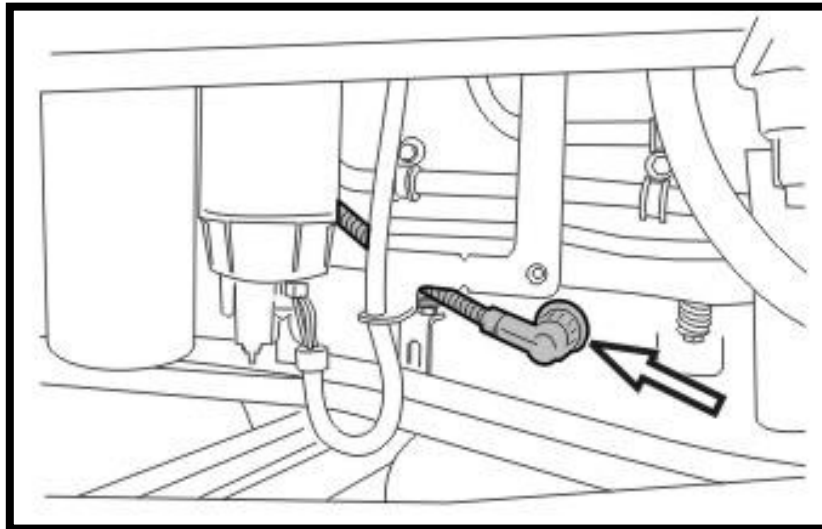

24. Connect the engine oil level/temperature sensor connector.

## 13L Oil Pickup Replacement

---

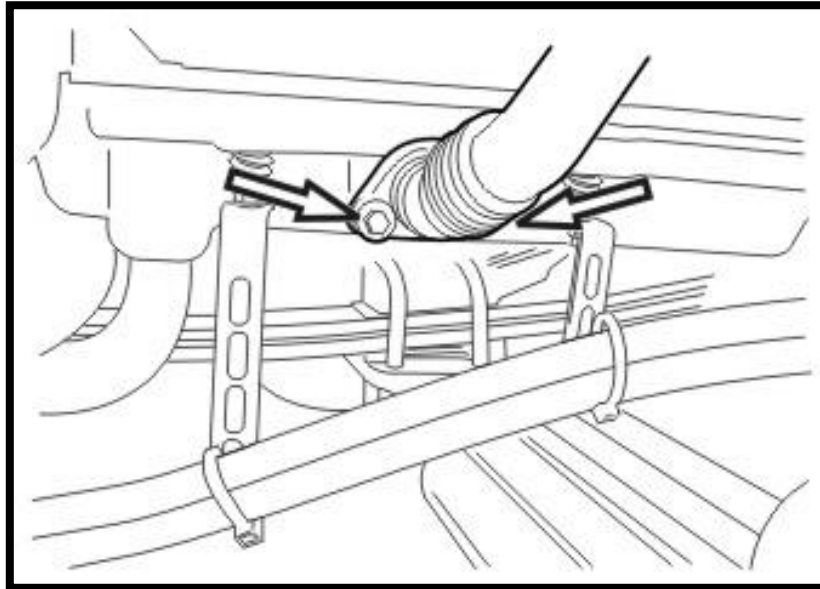

25. Install a new fill tube O-ring and position the fill tube onto the side of the oil pan. Install the oil fill tube fasteners and tighten to secure.

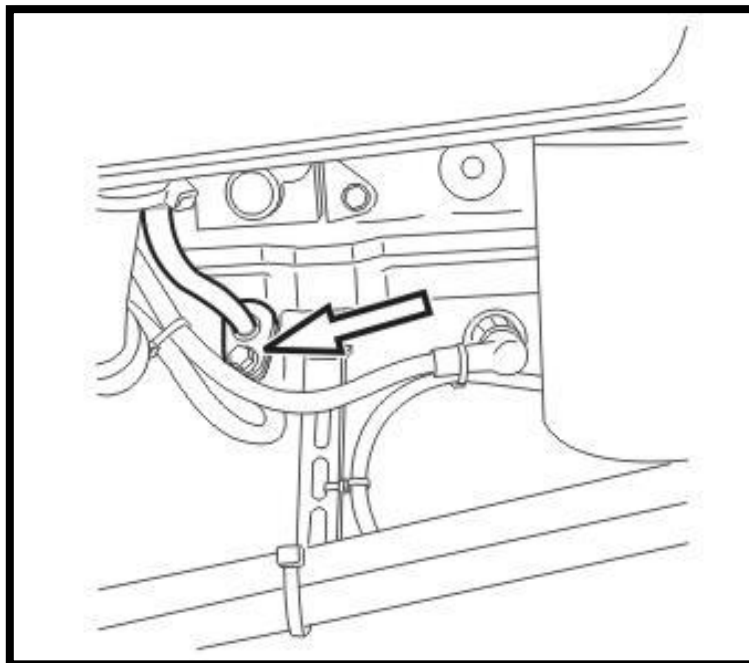

26. Install a new O-ring on the dipstick tube, then install the dipstick tube and secure with the fastener. Install the dipstick.

## 13L Oil Pickup Replacement

---

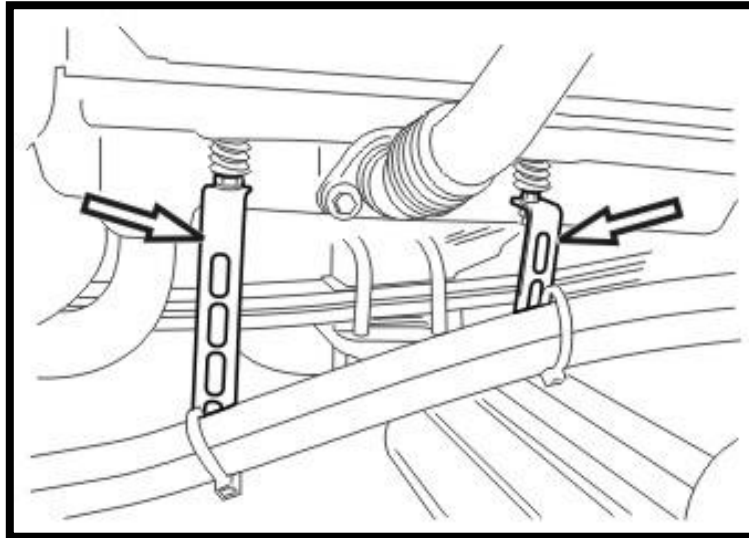

27. Position the transmission cooler and power steering line brackets onto the oil pan fastener stud locations. Install the cooler line bracket fasteners and tighten to secure.

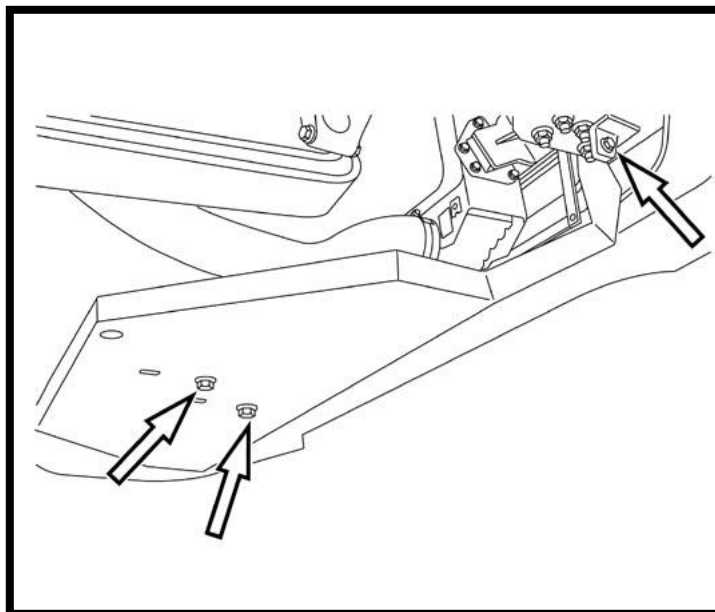

28. Install skid plate if removed for access.  
29. Using a hydraulic jack, raise the front axle and remove the jack stands from under the frame. Lower the front axle and remove the hydraulic jack.  
30. Replace engine oil filters.  
31. Fill the engine with approved oil to the full level on the dipstick.  
32. Reconnect all previously removed cables to the negative (ground) battery terminals.

## 13L Oil Pickup Replacement

---

33. Start the engine, check for leaks and proper operation. After shutdown, replenish fluids as necessary.
34. Close and latch the hood.
35. Remove the wheel chocks.