

Cab Height Adjustment with Air-Suspended Cabs

M-818-001

(March 2007)

Valid for

Mack CXU,CHU,GU,TD models built with air suspended cab

Case description

The purpose of this bulletin is to provide instructions and specifications for setting the desired cab height.

Note: Not Applicable to Mack Trucks Australia.

The following conditions and/or adjustments are required

1. The chassis must be sitting on a flat, level surface.
2. The chassis air system should be within the normal operating range of 100–130 psi.
3. All cab mounting, hood mounting, muffler mounting components and air cleaner mounting components are correctly installed to ensure free (unobstructed) movement of the cab.
4. There must not be any occupants in the cab and no change in cab weight during the adjustment procedure.
5. The cab is not leaning relative to the frame.

Procedures

1. Disconnect the levelling valve connecting rod from the levelling valve arm.
2. Manually operate the levelling valve arm to raise or lower the rear of the cab to obtain the proper cab height shown in the following chart. Take the measurement at dimension “A” in the illustration appropriate for the chassis on which you are working.



Warning

Perform the adjustment procedure from a safe location. Keep hands and arms, etc., out of the way to avoid injury.

Vehicle Model	Cab Rear Mounting Height Inches (mm)	Reference Illustration See Dimension “A”
R600	4.81 ± 0.06 (122.2 ± 1.5)	Figure 1
R700	7.19 ± 0.06 (182.6 ± 1.5)	Figure 1
RS600, RL600	8.00 ± 0.06 (203.2 ± 1.5)	Figure 1

U600	5.94 ± 0.06 (150.8 ± 1.5)	Figure 1
U700	10.94 ± 0.06 (277.9 ± 1.5)	Figure 1
WS700, WL700	11.06 ± 0.06 (280.9 ± 1.5)	Figure 2
MH	9.00 ± 0.06 (229.0 ± 1.5)	Figure 3
*RW	7.87 ± 0.06 (200.0 ± 1.5)	Figure 4
**RW	7.64 ± 0.06 (194.0 ± 1.5)	Figure 4
+CX, +CH	7.09 ± 0.06 (180.0 ± 1.5)	Figure 5
++CX, ++CH	7.64 ± 0.06 (194.0 ± 1.5)	Figure 6
+CL	7.09 ± 0.06 (180.0 ± 1.5)	Figure 7
++CL	7.64 ± 0.06 (194.0 ± 1.5)	Figure 8
CV manufactured prior to 4/2/01.	3.78 ± 0.12 (96.0 ± 3.0)	Figure 9
CV manufactured after 4/2/01.	4.69 ± 0.12 (119.0 ± 3.0)	Figure 9
RD800	12.50 ± 0.06 (317.5 ± 3.0)	Figure 10
+++CXU, +++CXP, +++CXN, +++CHU, +++CHN	7.00 ± 0.12 (178.0 ± 3.0)	Figure 11
GU7, GU8, CTP, CT	7.36 ± 0.12 (187 ± 3.0)	Figure 12
<p>* Denotes RW with air spring part number 227QS38 (5-inch diameter)</p> <p>** Denotes RW with air spring part number 227QS31M (6.5-inch diameter)</p> <p>+ Denotes CX, CH and CL with sleeper</p> <p>++ Denotes CX, CH and CL without sleeper</p> <p>+++ Denotes CXU, CXP, CXN, CHU and CHN, day cab or sleeper</p>		

3. With the cab at the proper height, adjust the length of the levelling valve connecting rod so that the mounting stud of the ball joint can be fully inserted into the hole in the levelling valve arm without moving the levelling valve arm.
4. After proper levelling valve connecting rod length has been obtained, firmly attach the mounting stud of the ball joint to the levelling valve arm and tighten the lock nuts on the connecting rod.

5. Recheck the cab mounting height. If it is not within the tolerance (shown in Table 1), repeat the above procedure starting at Step 1 until the proper height is achieved.

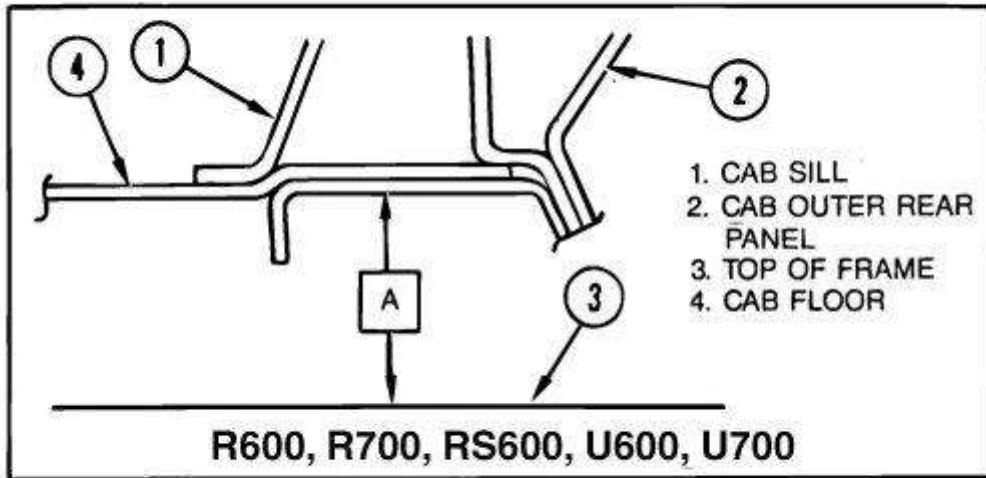

Figure 1 — R600, R700, RS600, RL600, U600, U700

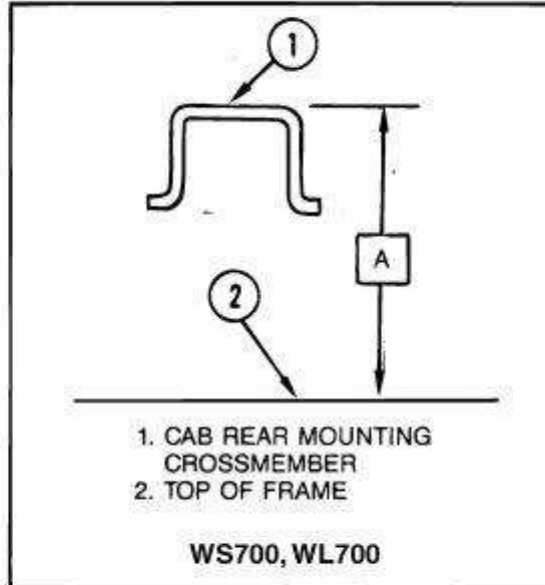

Figure 2 — WS700, WL700

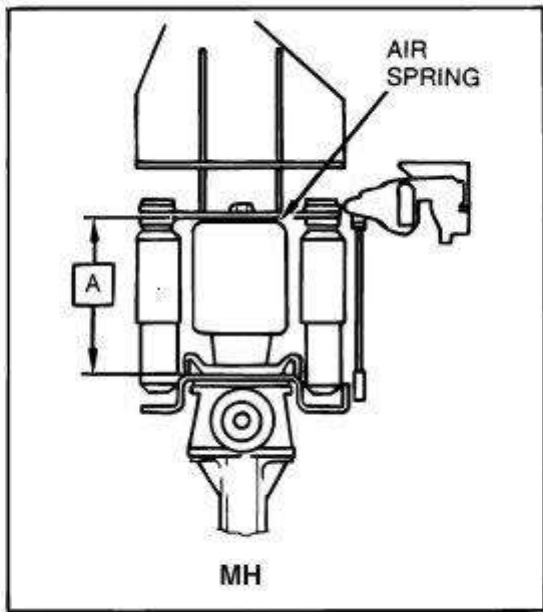

Figure 3 — MH

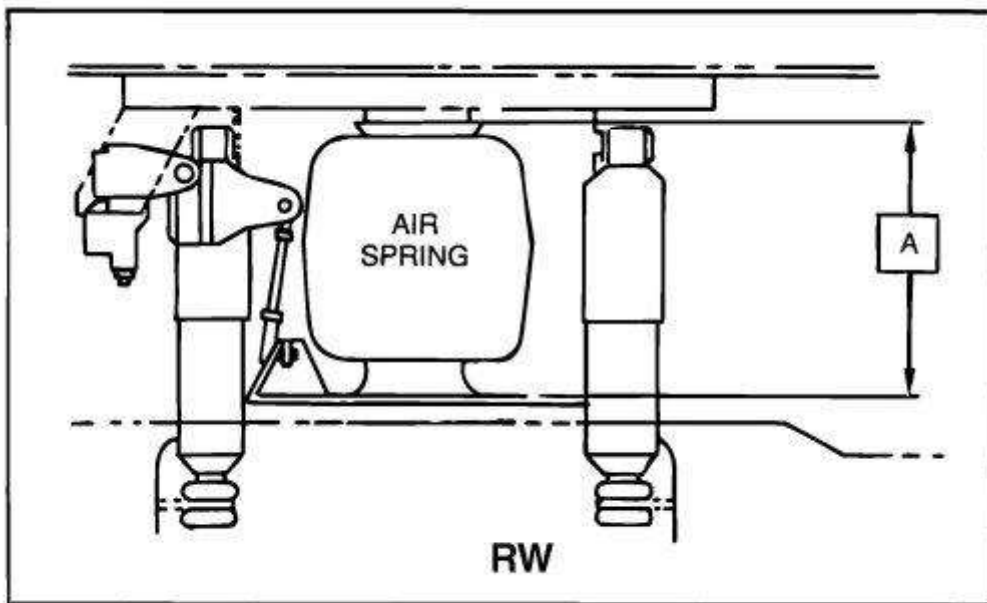

Figure 4 — RW

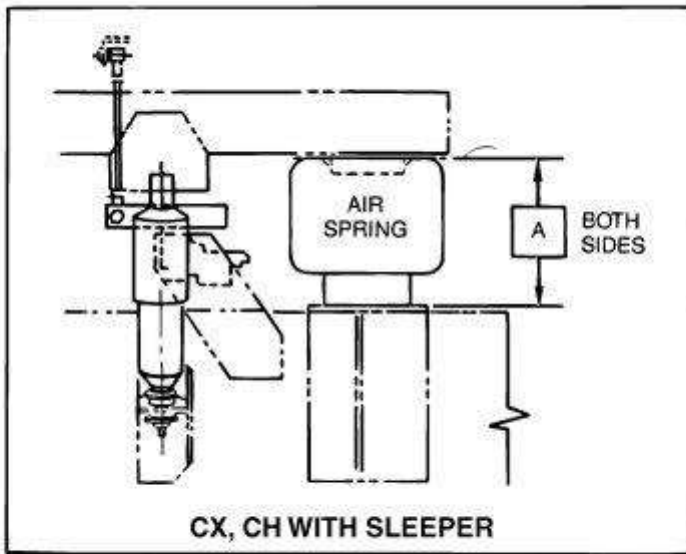

Figure 5 — CX, CH with Sleeper

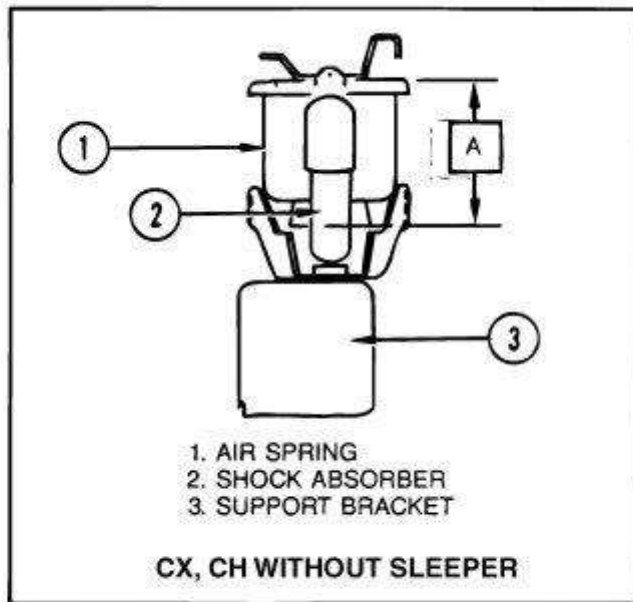

Figure 6 — CX, CH without Sleeper

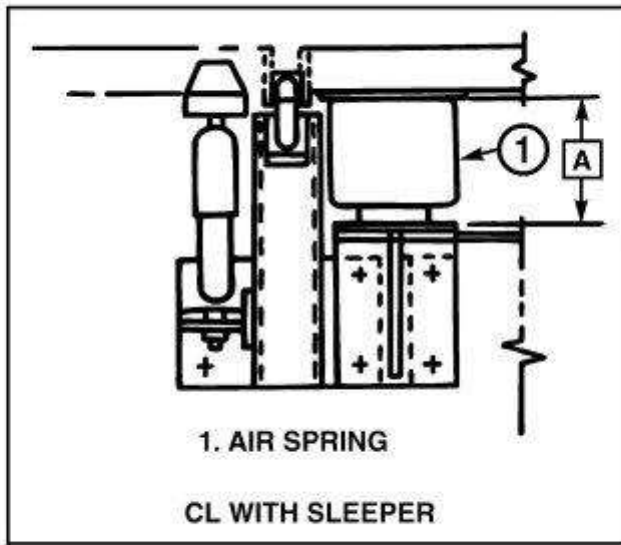

Figure 7 — CL with Sleeper

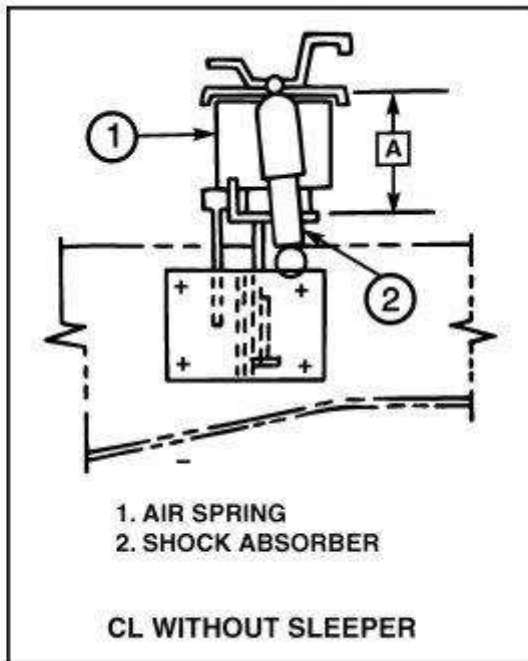

Figure 8 — CL without Sleeper

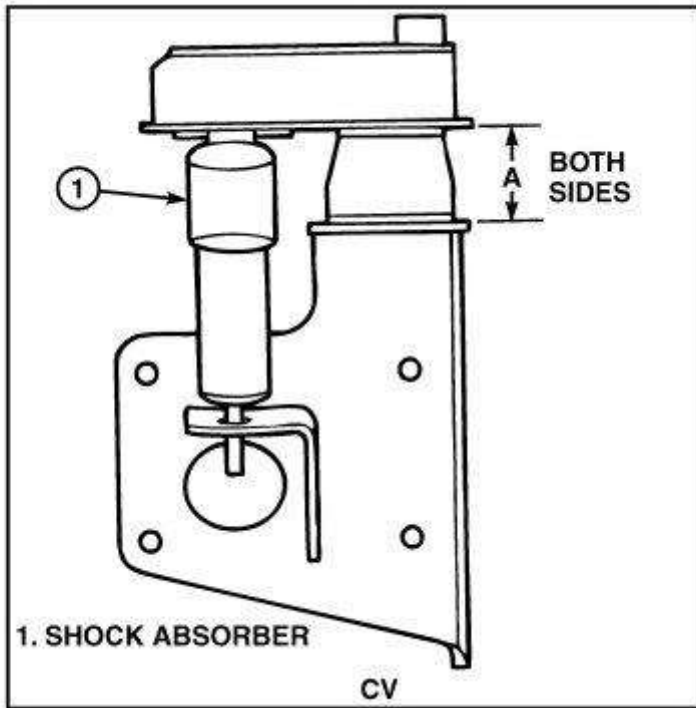

Figure 9 — CV

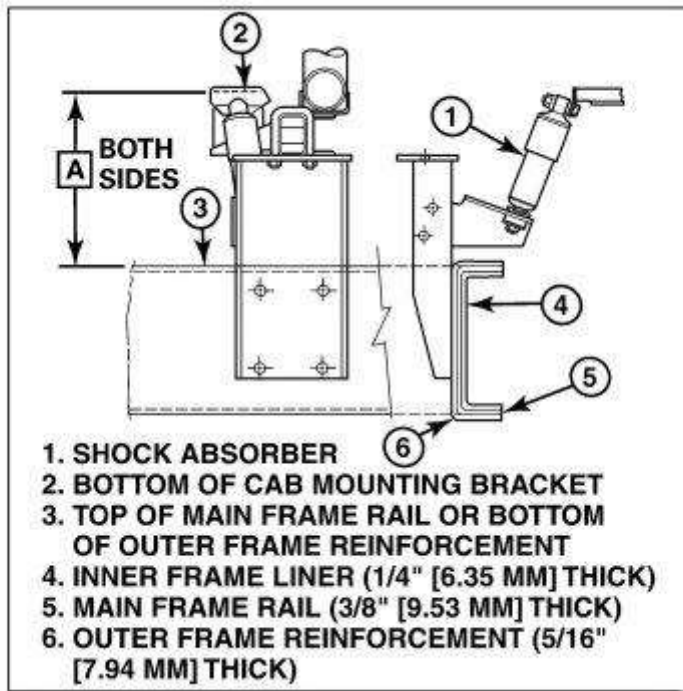

Figure 10 — RD800

Note: RD800 models can have a one, two or three element frame (main frame rail, inside frame liner and outer frame reinforcement). Cab ride height is always measured on the top of the main frame rail. To identify which frame configuration is being serviced, measure the frame thickness at the flange. The main frame rail is 3/8" (9.53 mm) thick, the inner liner is 1/4" (6.35 mm) thick and the outer frame reinforcement is 5/16" (7.94 mm) thick.

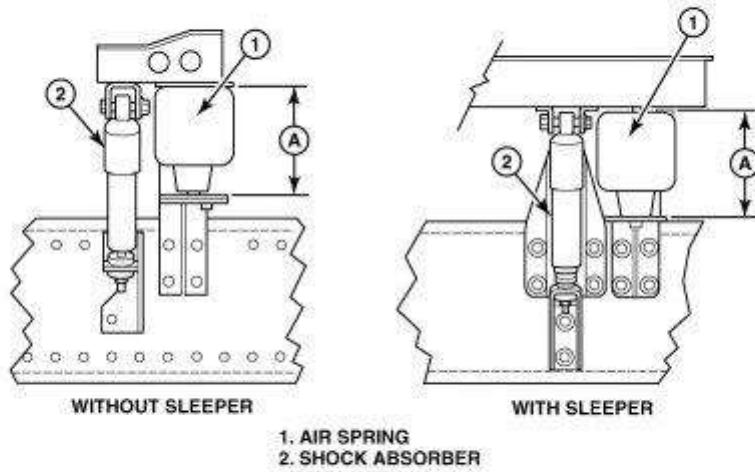

Figure 11 — CXU, CXP, CXN, CHU, CHN with and without Sleeper

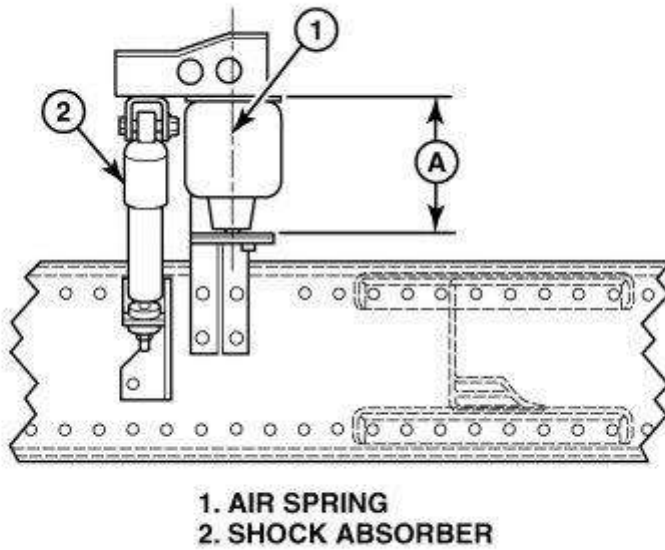

Figure 12 — GU7, GU8, CTP, CT

Issued by

Technical Service