

Synchronizer Assembly Fastener Change — T200 and T300 Transmissions

M-431-001

(April 2008)

Valid for

Mack CXU,CHU,GU,MRU,LEU built with a Mack T200-T300 trans and built before December 2007.

Case description

Effective November 28, 2007, a revised fastener (part number 551KC216) was implemented into production on the synchronizer assembly used in MACK T200 and T300 transmissions. This revised fastener incorporates Scotch-Grip™ adhesive, replacing the patch-lock type fastener, which was used previously. Should the synchronizer assembly be disassembled for any reason, it is recommended that these revised fasteners be used at reassembly. Tightening torque specification remains the same.

Parts

Synchronizer Assembly Fastener — T200 and T300 Transmissions

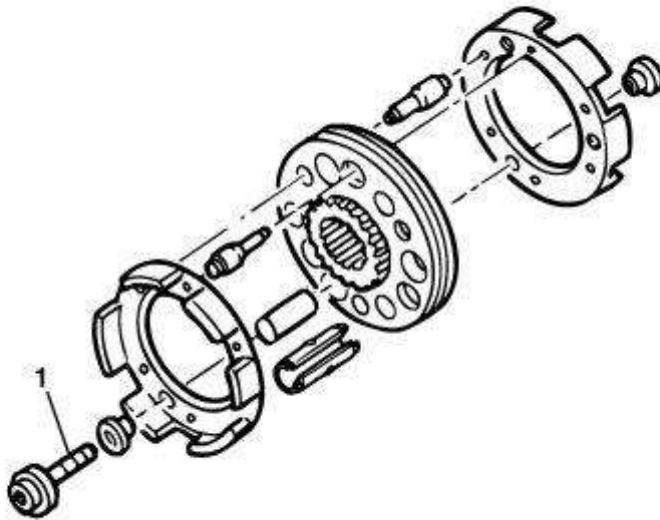

Key	Qty.	Part number	Description	Replaces
1	3	551KC216/ 21158575	Bolt with Scotch-Grip™ adhesive	25107877/ 6AX1606X/ 6AX1582

Note: These fasteners are one-time use fasteners only. They must be replaced anytime the synchronizer assembly is disassembled.

Issued by

Technical Service

Mack Trucks, Inc. engages in a continuous program of testing and evaluating to provide the best possible product. Mack Trucks, Inc., however, is not committed to, or liable for updating existing chassis.