



Service Bulletin

Bulletin No.: 22-NA-081

Date: October, 2022

TECHNICAL

Subject: Paint Peeling or Chipping on Front Fascia at Headlamp or Fender Seam

Brand:	Model:	Model Year:		VIN:		Engine:	Transmission:
		from	to	from	to		
Chevrolet	Corvette	2020	2023	—	—	All	All

Involved Region or Country	North America, Europe, Middle East, Japan, Australia/New Zealand
Condition	Some customers may comment on seeing the paint chipping or peeling on the front fascia, or the fender to fascia body seam.
Cause	The cause of the condition may be that the headlamp is positioned too tight to the body panel. The vehicle may also have too tight of a fit between the front fascia and fender.
Correction	Verify the condition and repair following the steps in the Service Procedure below.

Information

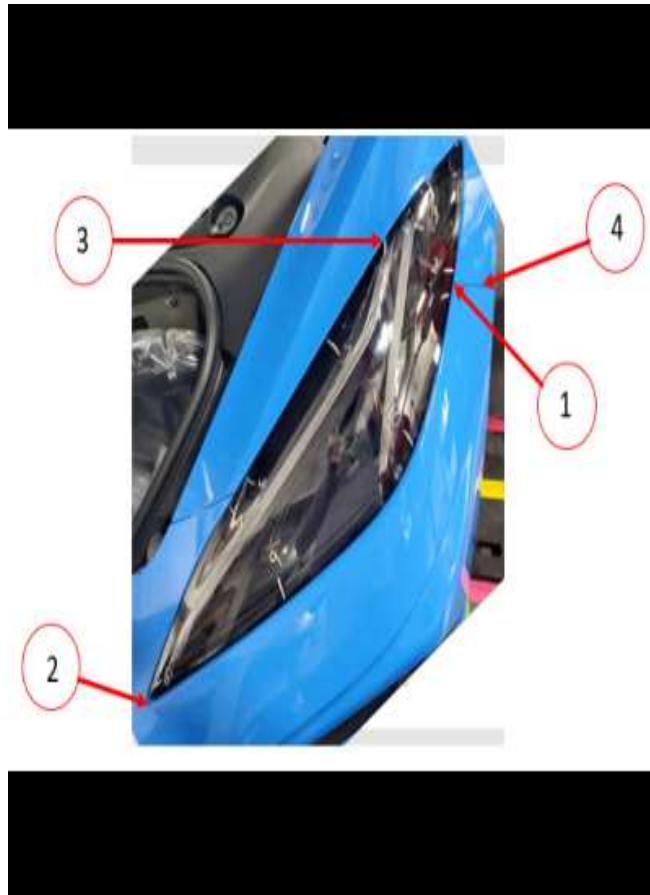

6041596

- There are four potential high contact areas where the paint may chip or peel:
1. Fender/fascia under headlamp (see Service Bulletin # 20-NA-124: Small Front Fascia Paint Chip Below Headlamp).
 2. Front corner of headlamp to the fascia.
 3. Head lamp tight to fender.
 4. Front fascia to fender.

Note: For further information, also refer to PIC6451.

Service Procedure

Important: Service agents must comply with all International, Federal, State, Provincial, and/or Local laws applicable to the activities it performs under this bulletin, including but not limited to handling, deploying, preparing, classifying, packaging, marking, labeling, and shipping dangerous goods. In the event of a conflict between the procedures set forth in this bulletin and the laws that apply to your dealership, you must follow those applicable laws.

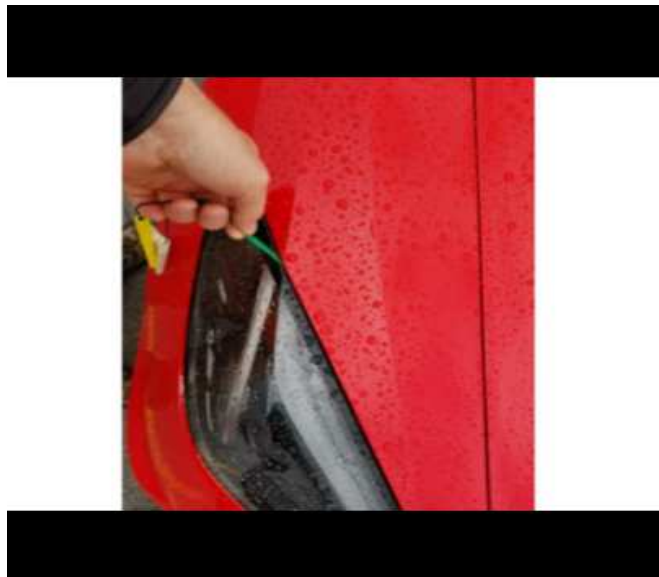

6041598

Note: Correct headlamp position should be confirmed **before** and **after** paint repairs are completed.

1. Measure the gap between the headlamp to the fender and fascia openings. The headlamp lens should have a minimum 0.5 mm (0.02 in) gap between the lens and the body panel.



6041601

2. Check for a tight gap at area # 2.

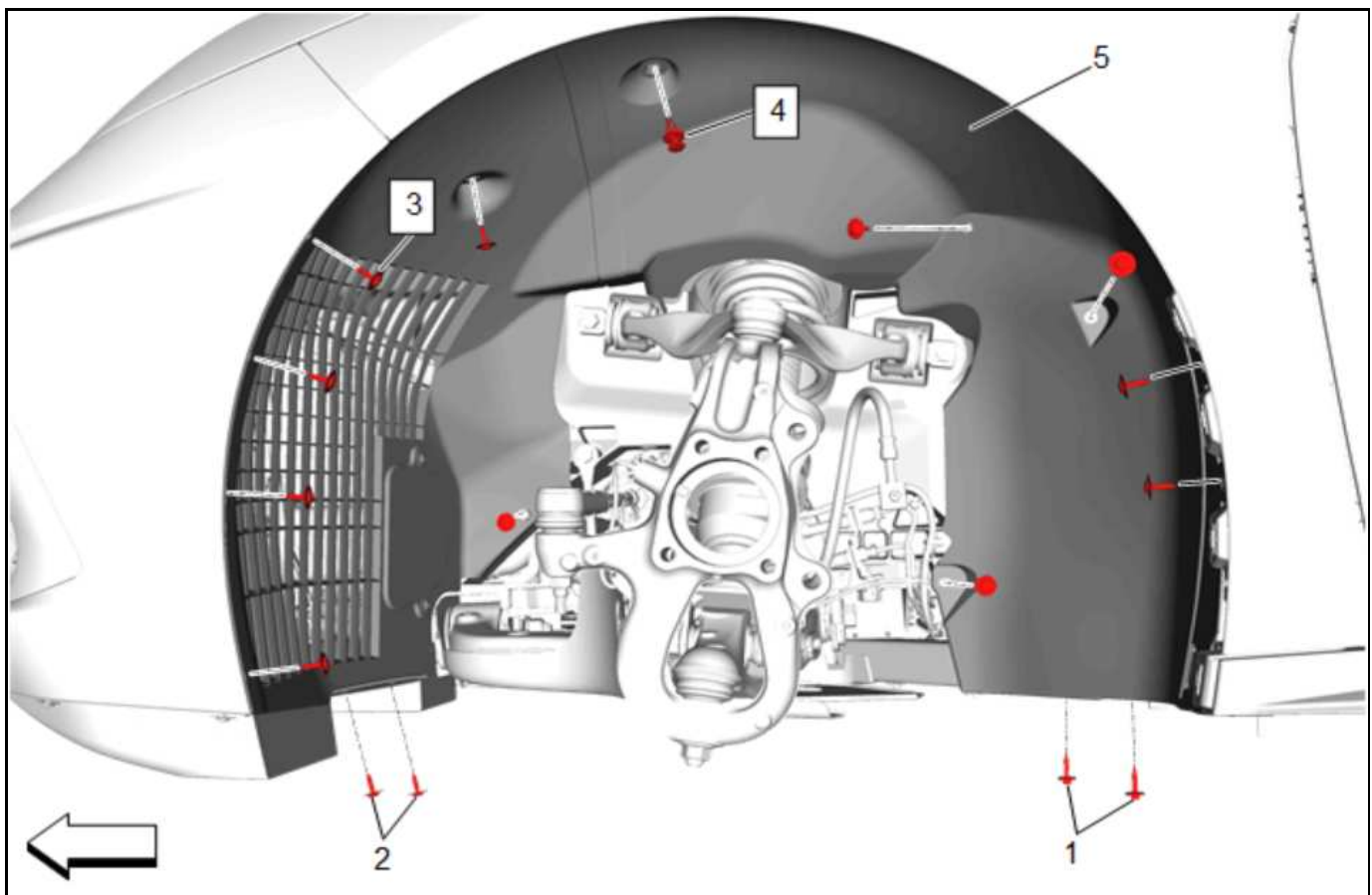

3. Remove both front tire/wheel assemblies and wheelhouse liners. Refer to the appropriate *Front Wheelhouse Liner Replacement* procedure in SI.



6041602

4. Remove the front fascia to gain access to the headlamp fasteners. Refer to *Front Bumper Fascia Removal and Installation* in the Service Manual.

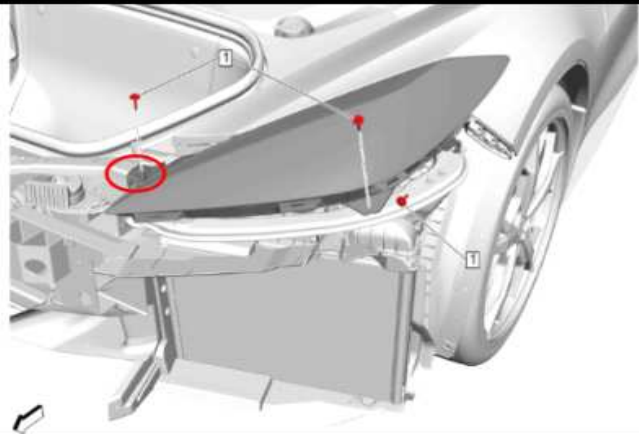

6041605

Note: In some cases, the forward mounting hole in the headlamp housing may need to be slightly enlarged to move the headlamp away from the fascia.

5. Adjust the headlamps on both sides, as necessary, by loosening the fasteners and moving the front corner of the headlamp away from the front compartment opening. Reinstall the bolt while holding the lamp in position. This will gain clearance between the headlamp and the fascia.

Tighten

Tighten the bolts to 2.5 N•m (22 lb in).

Important: Refer to the latest revision of the GM Approved Refinish Materials book to identify the paint systems you may use that have been engineered to meet GM standards.

The latest revision of the GM Approved Refinish Materials booklet is located on the Genuine GM Parts website at www.genuinegmparts.com and also within the "Unit Repair Manual/Specialty Publication" section of GM Service Information (SI).

6. Complete a partial paint repair to the affected location(s) of the front fascia. Refer to *Basecoat/Clearcoat Paint Systems* in the Service Manual.

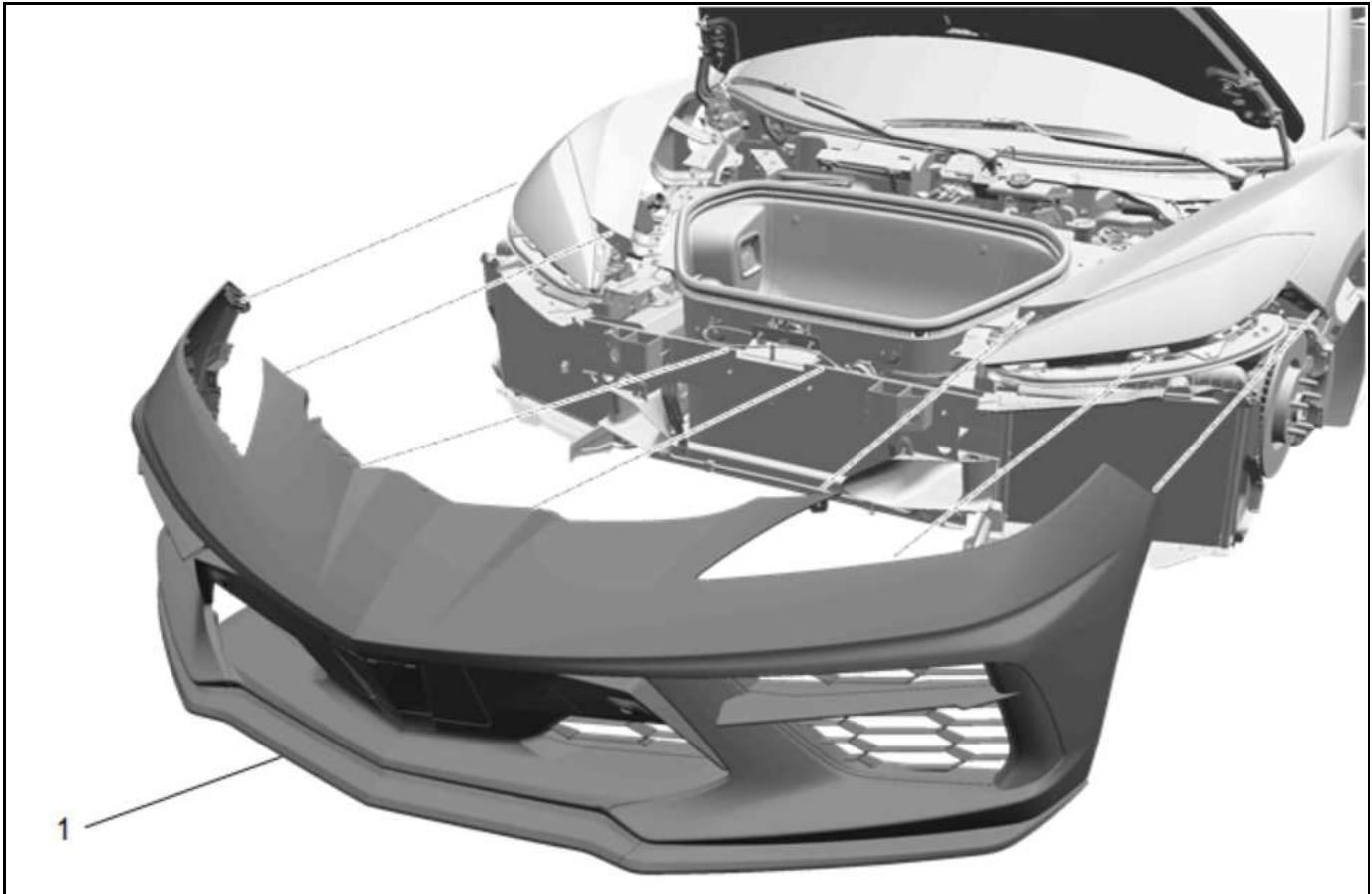

5354777

7. Reinstall the front fascia (1). Refer to *Front Bumper Fascia Removal and Installation* in the Service Manual.

Note: The gap may not be completely uniform all around the headlamp, however ensure the gap is at least 0.5 mm wide in all areas.

8. If a tight gap is noted at area #3, mark the location of the 2 cobra bracket bolts on each side of the vehicle and adjust the brackets:

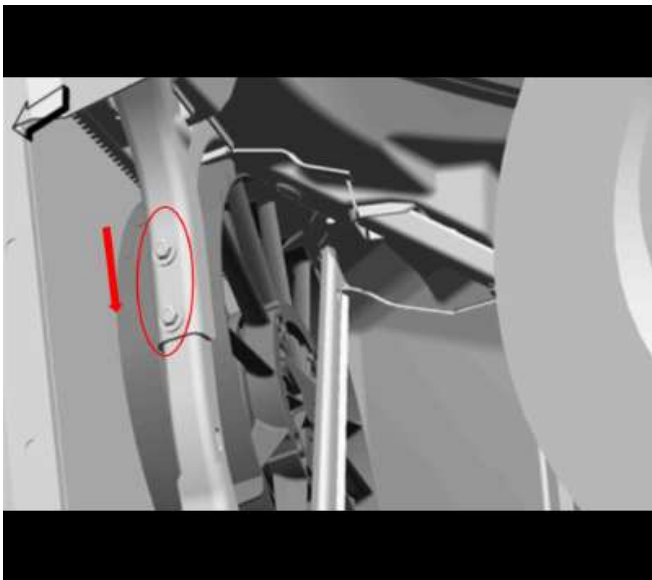

6041608



6041609

- 8.1. Loosen the cobra bracket bolts.
- 8.2. Lowering the bracket will create a larger gap between the headlamp lens and the fender.
- 8.3. Install a 0.5 mm feeler gauge between the headlamp and fender gap. Tighten the cobra bolts with the gauge in place.

Tighten

Tighten the bolts to 9 N•m (80 lb in).

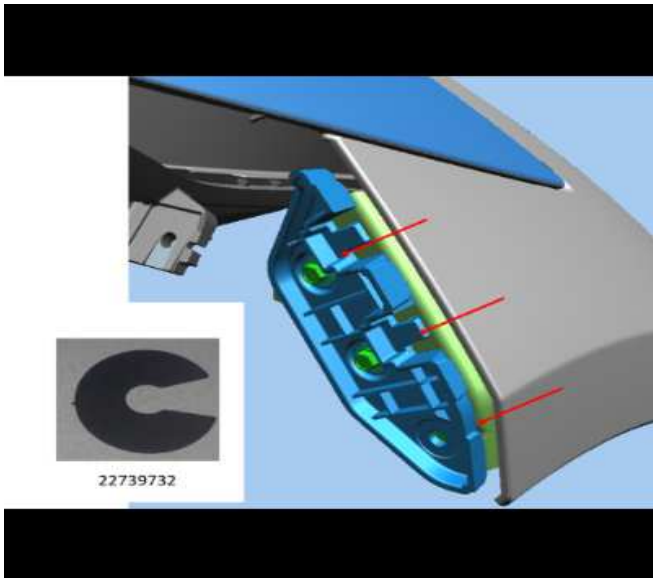

9. If a tight gap is noted at area # 4, install shims, P/N 22739732, between the bracket and the fender at the three locations shown.

Tighten

Tighten the bolts to 2.5 N•m (22 lb in).

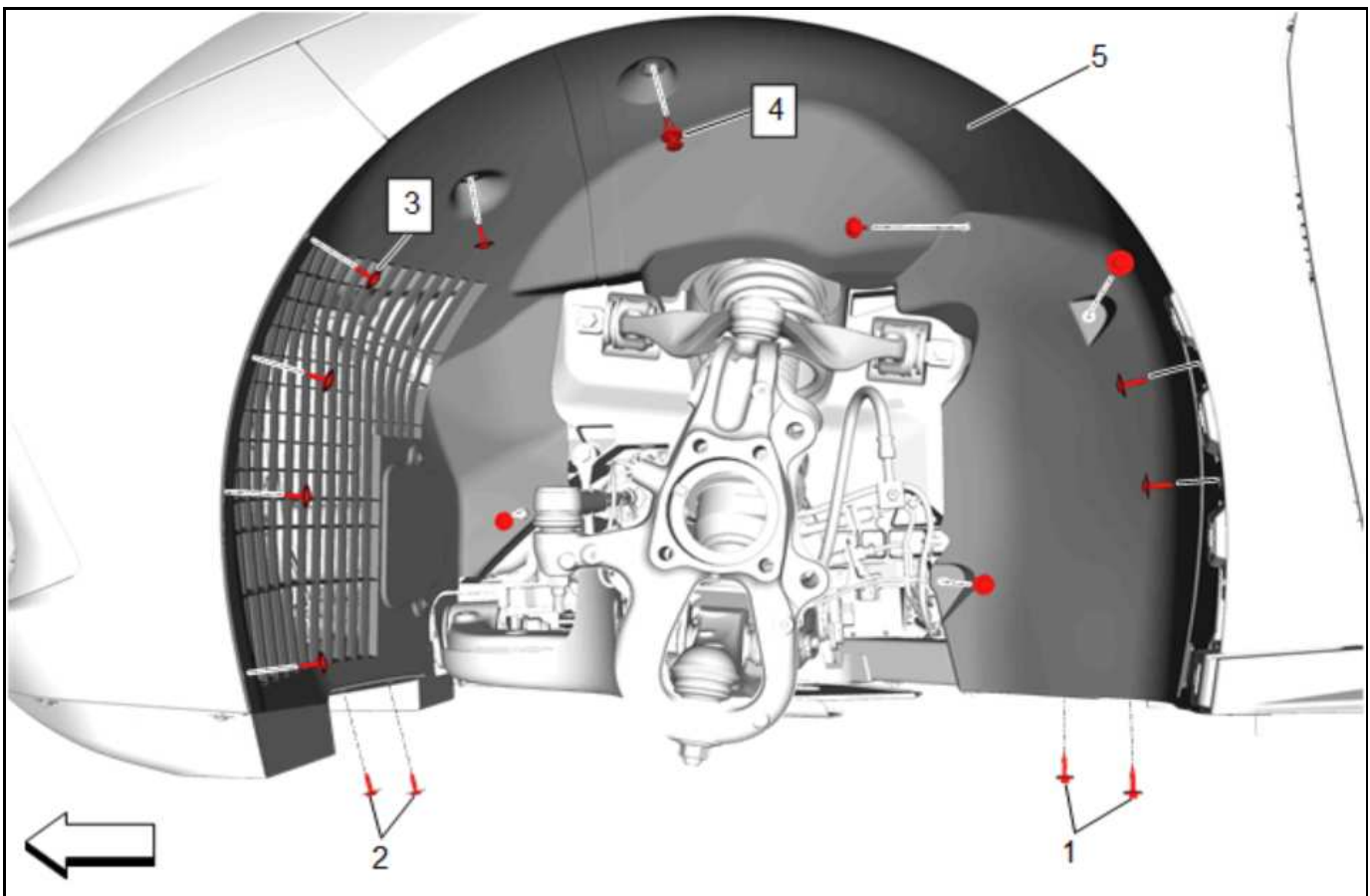

10. Reinstall both front tire/wheel assemblies and wheelhouse liners. Refer to the appropriate *Front Wheelhouse Liner Replacement* procedure in SI.

Warranty Information

For vehicles repaired under the Bumper-to-Bumper coverage (Canada Base Warranty coverage), use the following labor operation. Reference the Applicable Warranties section of Investigate Vehicle History (IVH) for coverage information.

Labor Operation	Description	Labor Time	Paint Code
1481628*	Remove and Install Front Fascia, Partial Refinish Color/Clearcoat, Adjust Headlamps and Cobra Brackets	4.6 hrs**	AM
Add	With Tint Coat/Tri-Coat Paint	0.3 hr	GC
Add	Install Shims One or Both Sides	0.1 hr	—

*This is a unique Labor Operation for bulletin use only.

**Includes repair/prime fascia, and Paint Mix Time

Version	2
Modified	Released April 13, 2022 Revised October 04, 2022 – Added the 2023 Model Year and an Important statement at start of Service Procedure.

