

Front Brake Squeal/Squeak Noise

Service Category Brake

Section Brake (front)

Market USA

Toyota Supports
ASE Certification 

Applicability

YEAR(S)	MODEL(S)	ADDITIONAL INFORMATION
2018 - 2022	Camry, Camry HV	

SUPERSESION NOTICE

The information contained in this bulletin supersedes Service Bulletin T-SB-0015-20.

- Applicability has been updated to include 2022 model year Camry and Camry Hybrid vehicles. Service Bulletin T-SB-0015-20 is obsolete and any printed versions should be discarded.

Introduction

Some 2018 – 2022 model year Camry and Camry Hybrid vehicles may exhibit a brake squeal/squeak noise from the front brake components. A new brake caliper assembly and fitting kit has been developed to address this condition. Follow the Repair Procedures in this bulletin to address this condition.

Front Brake Squeal/Squeak Noise

Production Change Information

This bulletin applies to vehicles produced **BEFORE** and **AFTER** the Production Change Effective VINs shown below.

- For 2018 model year vehicles produced **BEFORE** the Production Change Effective VINs shown below perform Repair Procedure A.
- For 2018 model year vehicles produced **AFTER** the Production Change Effective VINs shown below perform Repair Procedure B.
- For ALL 2019 – 2022 model year vehicles perform Repair Procedure B.

NOTE

If the first three digits of the VIN begin with 4T1 and the 12th digit of the VIN is between 0 and 4, reference the table below.

MODEL	GRADE	ENGINE	PRODUCTION CHANGE EFFECTIVE VIN
Camry	L, LE, SE, XLE	4 Cyl.	4T1B11HK#JU144761
	XSE		4T1B61HK#JU144761
	LE	HV	4T1B31HK#JU004476
	SE, XLE		4T1B21HK#JU009132
	XLE, XSE	6 Cyl.	4T1BZ1HK#JU020370

NOTE

If the first three digits of the VIN begin with 4T1 and the 12th digit of the VIN is between 5 and 9, reference the table below.

MODEL	GRADE	ENGINE	PRODUCTION CHANGE EFFECTIVE VIN
Camry	L, LE, SE, XLE	4 Cyl.	4T1B11HK#JU662207
	XSE		4T1B61HK#JU662207
	LE	HV	4T1B31HK#JU507718
	SE, XLE		4T1B21HK#JU510071
	XLE, XSE	6 Cyl.	4T1BZ1HK#JU506701

Front Brake Squeal/Squeak Noise

Production Change Information (continued)

NOTE

- If the first three digits of the VIN begin with JTN, reference the table below.
- Repair Procedure B does NOT apply to Japan-built vehicles.

MODEL	GRADE	ENGINE	PRODUCTION CHANGE EFFECTIVE VIN
Camry	LE	4 Cyl.	JTNB11HK#J3071474
	SE		JTNB11HK#J3071473

Warranty Information

Repair Procedure A

OP CODE	DESCRIPTION	MODEL	TIME	OPF	T1	T2
473101	R & R Front Brake Calipers	Camry	1.1	47750-#####*	36	99
		Camry HV	1.2			
Combo A	Opposite Side**	All	0.2			

*Warranty claim MUST be submitted with the correct 10-digit OPF. Choose the correct OPF for the vehicle being repaired by searching for the parts in the Electronic Parts Catalog using the VIN filter.

**Both sides are to be replaced under this Service Bulletin.

APPLICABLE WARRANTY

- This repair is covered under the Toyota Basic Warranty. This warranty is in effect for 36 months or 36,000 miles, whichever occurs first, from the vehicle's in-service date.
- Warranty application is limited to occurrence of the specified condition described in this bulletin.

Repair Procedure B

OP CODE	DESCRIPTION	MODEL	TIME	OPF	T1	T2
BR1914	R & R Front Shim Kit (Both Sides*)	Camry	0.7	04465-0E060	36	99
BR1915		Camry HV	0.7			

*Both sides are to be replaced under this Service Bulletin.

APPLICABLE WARRANTY

- This repair is covered under the Toyota Basic Warranty. This warranty is in effect for 36 months or 36,000 miles, whichever occurs first, from the vehicle's in-service date.
- Warranty application is limited to occurrence of the specified condition described in this bulletin.

Front Brake Squeal/Squeak Noise

Parts Information

NOTE

For North America produced vehicles (4T1), order both fitting kit part numbers listed.

Repair Procedure A

WMI	PART NUMBER		PART NAME	QTY
	PREVIOUS	NEW		
4T1	47750-06320	47750-06321	Cylinder Assy, LH	1
	47730-06320	47730-06321	Cylinder Assy, RH	1
	04947-0E030	04947-0E031	Fitting Kit, Disc, Front	1
	04947-06130		Fitting Kit, Disc, Front	1
	47389-50021		Brake Hose Gaskets	2
	00475-13F03		Brake Fluid	1
JTN	47750-33380	47750-33311	Cylinder Assy, LH	1
	47730-33380	47730-33381	Cylinder Assy, RH	1
	04947-33280	04947-33281	Fitting Kit, Disc, Front	1
	47389-50021		Brake Hose Gaskets	2
	00475-13F03		Brake Fluid	1

Repair Procedure B

WMI	PART NUMBER	PART NAME	QTY
4T1	04947-06130	Fitting Kit, Disc, Front	1
JTN	Repair Procedure B Does Not Apply to Japan-built Vehicles		

Front Brake Squeal/Squeak Noise

Required Tools & Equipment

REQUIRED EQUIPMENT	SUPPLIER	PART NUMBER	QTY
Techstream ADVi*	ADE	TSADVUNIT	1
Techstream 2.0		TS2UNIT	
Techstream Lite		TSLITEPDLR01	
Techstream Lite (Green Cable)		TSLP2DLR01	

*Essential SST.

NOTE

- Only ONE of the Techstream units listed above is required.
- Software version 17.20.013 or later is required.
- Additional Techstream units may be ordered by calling Approved Dealer Equipment (ADE) at 1-800-368-6787.

REQUIRED EQUIPMENT	SUPPLIER	PART NUMBER	QTY
ChassisEAR™ (or equivalent)	ADE	JSP06608 (JS Products)	1

NOTE

- A mechanic's stethoscope or similar tool may be used in place of ChassisEAR™.
- ChassisEAR™ may be ordered by calling Approved Dealer Equipment (ADE) at 1-800-368-6787.

Repair Procedure

Repair Procedure A

1. Confirm the condition exists.

NOTE

- Brake squeal may be more likely at slower speeds.
- If necessary, use ChassisEar™ (or equivalent) to help identify the source of the noise.

Does the vehicle exhibit a squeal/squeak noise from the front brake components?

- **YES** — Continue to step 2.
- **NO** — This bulletin does NOT apply. Continue diagnosis using the applicable Repair Manual.

Front Brake Squeal/Squeak Noise

Repair Procedure (continued)

Repair Procedure A (continued)

2. Replace BOTH front brake caliper assemblies.

A. Remove the front brake caliper assemblies.

Refer to TIS, applicable model and model year Repair Manual:

- 2018 Camry:
Brake – Brake (Front) – [“Brake \(Front\): Front Brake \(except 2-Pot Caliper\): Removal”](#)
- 2018 Camry HV:
Brake – Brake (Front) – [“Brake \(Front\): Front Brake: Removal”](#)

B. Install the UPDATED front brake caliper assemblies.

Refer to TIS, applicable model and model year Repair Manual:

- 2018 Camry:
Brake – Brake (Front) – [“Brake \(Front\): Front Brake \(except 2-Pot Caliper\): Installation”](#)
- 2018 Camry HV:
Brake – Brake (Front) – [“Brake \(Front\): Front Brake: Installation”](#)

NOTE

Use Repair Procedure B when installing fitting kit (the two separate fitting kits) for North America Produced Vehicle (4T1).

3. Confirm the squeal/squeak noise is no longer present.

Repair Procedure B

1. Confirm the condition exists.

NOTE

- Brake squeal may be more likely at slower speeds.
- If necessary, use ChassisEar™ (or equivalent) to help identify the source of the noise.

Does the vehicle exhibit a squeal/squeak noise from the front brake components?

- **YES** — Continue to step 2.
- **NO** — This bulletin does NOT apply. Continue diagnosis using the applicable Repair Manual.

Front Brake Squeal/Squeak Noise

Repair Procedure (continued)

Repair Procedure B (continued)

2. Replace BOTH front brake fitting kit assemblies (outer side ONLY).

A. Remove front brake pads.

Refer to TIS, applicable model and model year Repair Manual:

- 2018 – 2022 Camry:
General – Maintenance – [“Maintenance: Front Disc Brake Pad: Removal”](#)
- 2018 – 2020 Camry HV:
General – Maintenance – [“Maintenance: Front Disc Brake Pad: Removal”](#)
- 2021 – 2022 Camry HV:
General – Maintenance – [“Maintenance: Front Disc Brake Pad: Removal”](#)

B. Remove the outer side fitting kit assembly ONLY.

Figure 1.

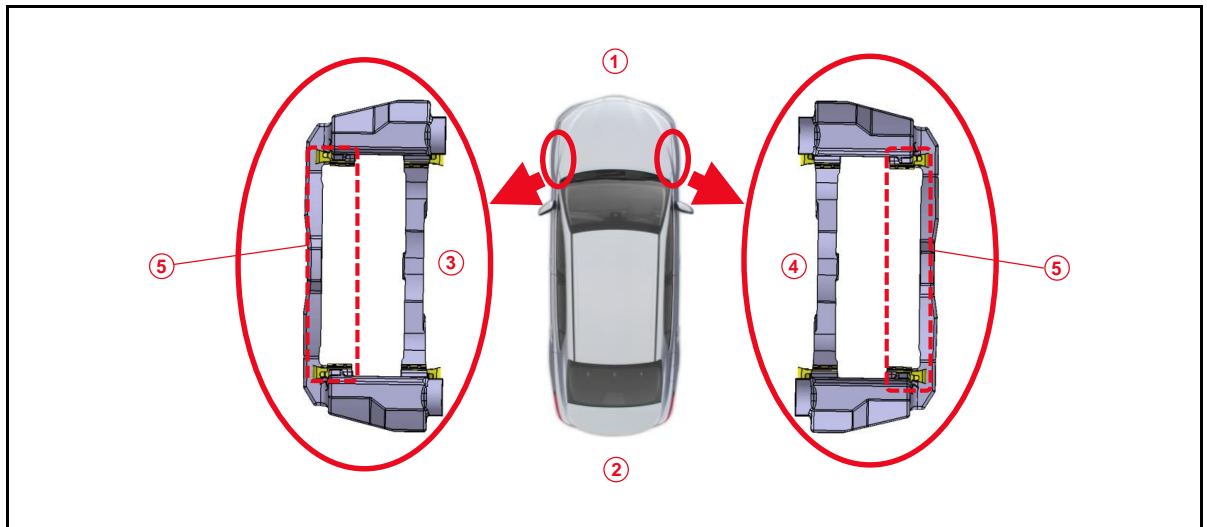

1	Front
2	Rear
3	Left

4	Right
5	Outer Side Fitting Kit Assembly

Front Brake Squeal/Squeak Noise

Repair Procedure (continued)

Repair Procedure B (continued)

- C. Remove the four pieces from the fitting kit (P/N 04947-06130) and apply the Wako grease that is included in the kit.

Figure 2.

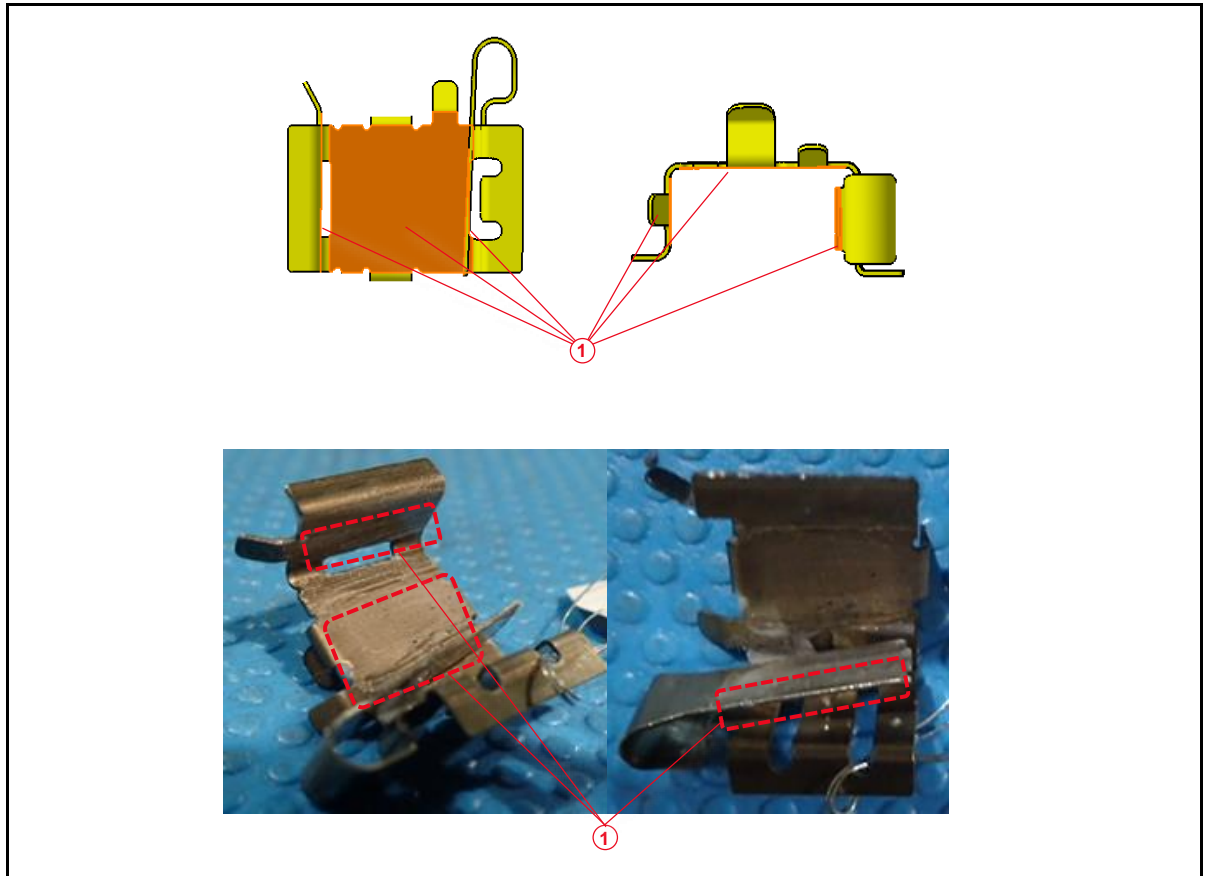

1	Grease Location
----------	------------------------

NOTE
 Grease is to stay ONLY within the pad clip on specified areas (total Wako grease quantity: 0.0075g).

Front Brake Squeal/Squeak Noise

Repair Procedure (continued)

Repair Procedure B (continued)

- D. Install the four fitting kit pieces with Wako grease applied onto the outer side of the caliper brackets.
Use the original fitting kit for the inner side of the bracket (P/N 04947-0E031).

Figure 3.

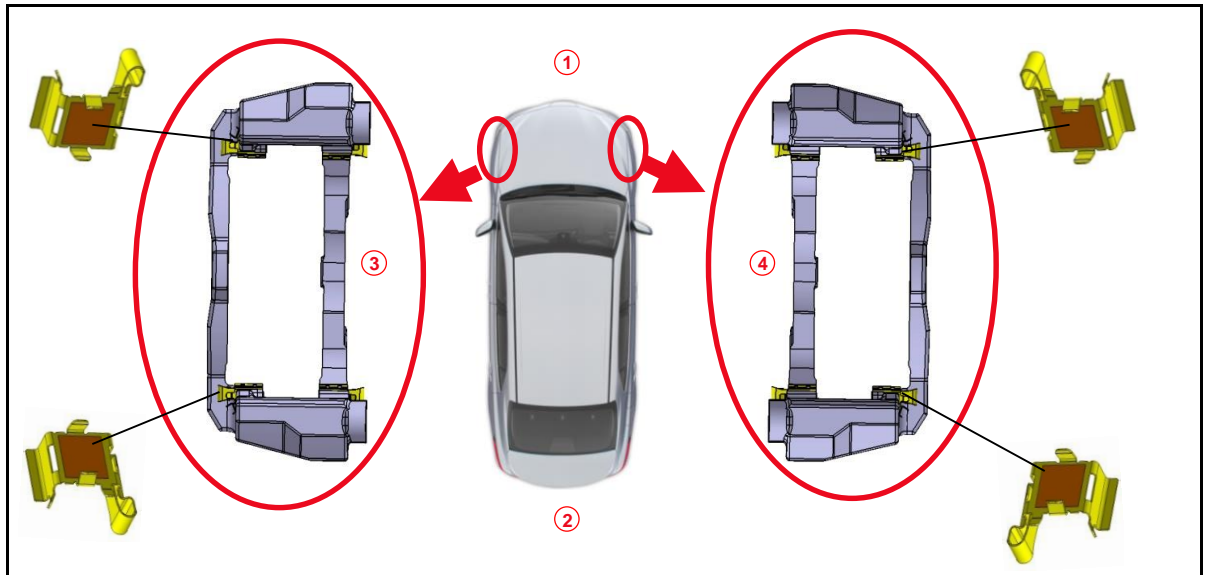

1	Front
2	Rear

3	Left
4	Right

- E. Install the front brake pads.
Refer to TIS, applicable model and model year Repair Manual:
- 2018 – 2022 Camry:
General – Maintenance – [“Maintenance: Front Disc Brake Pad: Installation”](#)
 - 2018 – 2022 Camry HV:
Brake – Brake (Front) – [“Brake \(Front\): Front Disc Brake Pad: Installation”](#)

3. Confirm the squeal/squeak noise is no longer present.