

2023 Sienna HV Pre-Delivery Service (PDS)

Service Category General

Section Pre-Delivery Service

Market USA

Toyota Supports
 ASE Certification 

Applicability

YEAR(S)	MODEL(S)	ADDITIONAL INFORMATION
2023	Sienna HV	

Introduction

Pre-Delivery Service (PDS) is a critical step in satisfying our new car customers. Customer feedback indicates the following areas deserve special attention when performing PDS:

- Careful inspection for paint chips/scratches and body dents/dings.
- Proper operation of electrical accessories (including interior light, clock, and radio reset).
- Interior cleanliness.
- Proper function of mechanical systems.

Customer retention and proper maintenance of vehicles are and have always been a major focus for Toyota. To help remind customers that regular service is essential to the proper maintenance of the vehicle, dealers are required to install a service reminder sticker before delivery. By doing this, customers will be reminded to return to your dealership for service. Your current service reminder sticker may be used. (See PDS Check Sheet item 8 of “Final Inspection and Cleaning.”)

This bulletin contains the PDS procedures that apply specifically to 2023 model year Sienna Hybrid vehicles. A universal PDS [Check Sheet](#) that contains PDS steps that apply to all 2023 model year Toyota vehicles has been developed. To properly perform a complete PDS, you must complete all procedures contained in this TSB as well as the universal PDS [Check Sheet](#).

In addition, if the vehicle is stored for over 30 days, be sure to follow [Long-Term Vehicle Storage Guidelines](#).

2023 Sienna HV Pre-Delivery Service (PDS)

Warranty Policy

If the need for additional repairs or adjustment is noted during PDS, the required service should be performed under warranty. Reimbursement will be managed under the warranty policy.

The Warranty Policy and Procedures Manual requires that you maintain the completed Check Sheet in the customer's file. If you cannot produce a completed form for each retailed vehicle upon TMS and/or Region/Distributor audit, the PDS payment amount will be subject to debit.

An additional Repair Order completed in conjunction with normal PDS MUST have time punch/flags for service. If multiple repairs are performed, separate time flags MUST be punched for each repair.

Warranty Information

OP CODE	DESCRIPTION	MODEL	TIME	OFP	T1	T2
001013	Pre-Delivery Service (PDS)	Sienna HV	1.5	-	-	-

Required Tools & Equipment

REQUIRED EQUIPMENT	SUPPLIER	PART NUMBER	QTY
Techstream ADVi*	ADE	TSADVUNIT	1
Techstream 2.0		TS2UNIT	
Techstream Lite		TSLITEPDLR01	
Techstream Lite (Green Cable)		TSLP2DLR01	

*Essential SST.

NOTE

- Only ONE of the Techstream units listed above is required.
- Software version 17.10.012 or later is required.
- Additional Techstream units may be ordered by calling Approved Dealer Equipment (ADE) at 1-800-368-6787.

2023 Sienna HV Pre-Delivery Service (PDS)

Procedures

- [D/C Cut Fuse Installation](#).....4
- [Power Sliding Door Initialization](#)4
- [Power Back Door Initialization*](#)4
- [Floor Plug Installation*](#)5
- [Seating Position Control ECU Initialization*](#)6
- [Memorize Steering Angle Neutral Point](#)6
- [Perform Steering Sensor Zero Point Calibration*](#)6
- [Front Wheel Opening Extension Pad Installation](#)7
- [Front License Plate and Mounting Bracket Installation](#).....8
- [Installation of Rubber Body Plugs*](#)9
- [Tire Pressure Warning System \(TPWS\) Initialization](#)10
- [Dealer Contact Information for Call Dealer Head Unit Function*](#)10

*If applicable.

2023 Sienna HV Pre-Delivery Service (PDS)

D/C Cut Fuse Installation

To minimize battery discharge, the D/C cut fuse (25A) has been removed and is stored in the engine compartment relay block. Install the D/C cut fuse (25A) and confirm ALL related Diagnostic Trouble Codes (DTCs) are cleared.

Figure 1.

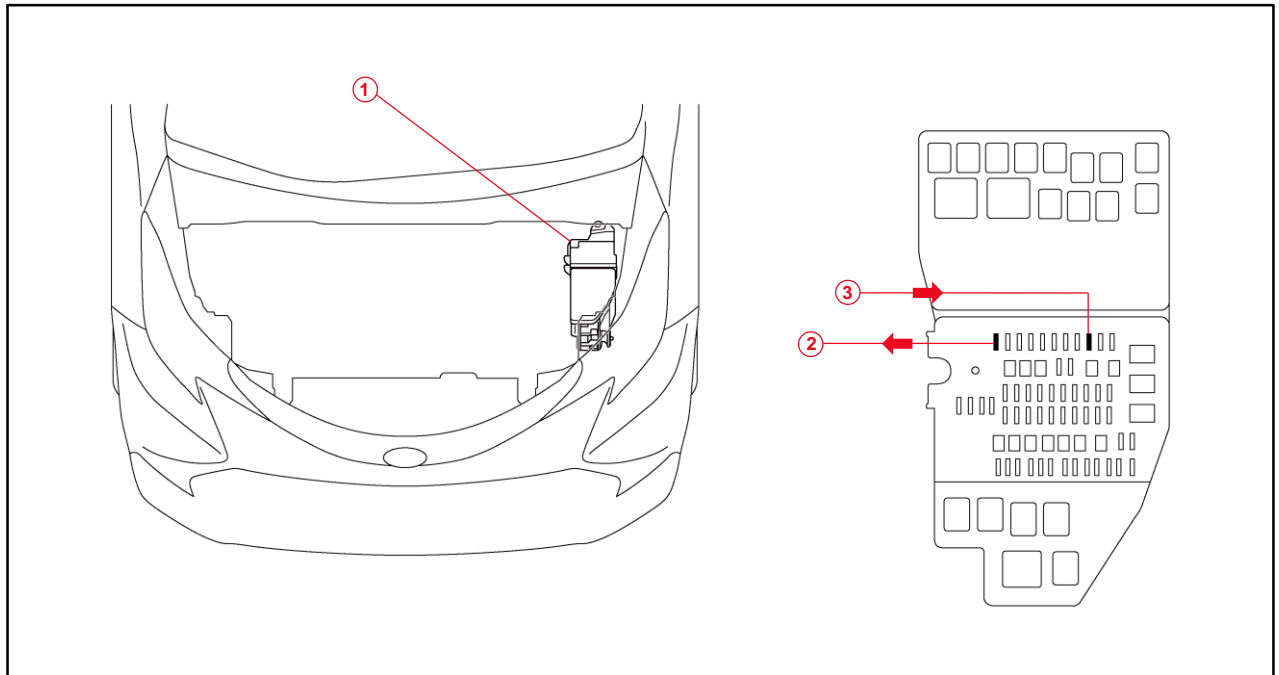

1	Relay Block
2	Remove D/C Cut Fuse (25A)
3	Install D/C Cut Fuse (25A)

Power Sliding Door Initialization

Initialize the power sliding door system AFTER installing the D/C cut fuse during PDS by moving the sliding door once to the fully closed position manually.

Power Back Door Initialization

Initialize the power back door system AFTER installing the D/C cut fuse during PDS by fully closing the back door manually.

2023 Sienna HV Pre-Delivery Service (PDS)

Floor Plug Installation

Some 2023 model year Sienna Hybrid vehicles are NOT equipped with floor mats. If floor mats are NOT included with the vehicle, use the floor plugs to plug the three floor grommets in the second row, and the three grommets in the third row. The floor plugs are stored in the luggage compartment where you would normally find the floor mats.

NOTE

This procedure does NOT apply to vehicles equipped with floor mats.

1. Insert six floor plugs in the open grommets located in the second and third rows.

2. Press firmly on top of the plug to ensure proper installation.

3. Verify ALL six floor plugs have been installed correctly.

Figure 2.

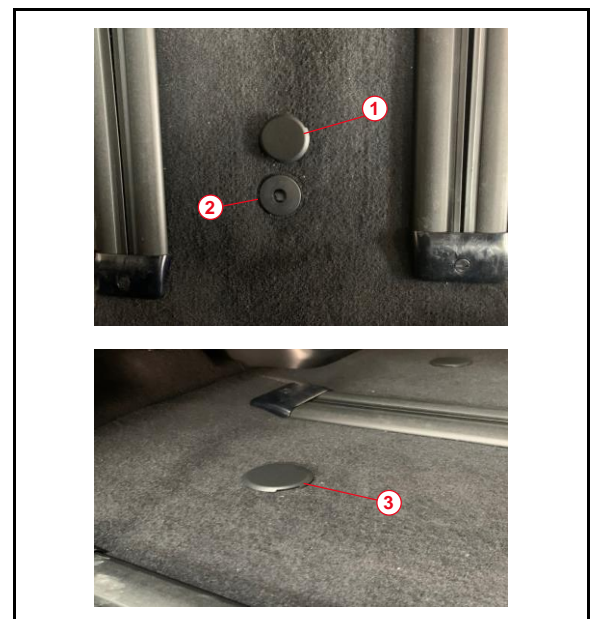

1	Uninstalled Floor Plug
2	Open Grommet
3	Installed Floor Plug

2023 Sienna HV Pre-Delivery Service (PDS)

Seating Position Control ECU Initialization

Refer to the applicable Repair Manual for the seating position control ECU [initialization procedure](#) (procedure 2).

Memorize Steering Angle Neutral Point

As a result of the removal of the D/C cut fuse, the power source to the steering angle sensor is cut off. When the D/C cut fuse is reinstalled, the parking assist monitor system/panoramic view monitor system will be operative, but it cannot display guidelines to assist parking operation because the center position recognized by the steering angle sensor may not be in an initial position. Therefore, perform steering angle neutral point initialization AFTER installing the D/C cut fuse during PDS.

Refer to the applicable Repair Manual for the steering angle neutral point [initialization procedure](#).

Perform Steering Sensor Zero Point Calibration

As a result of the removal of the D/C cut fuse, the steering angle sensor power source is cut off. When the D/C cut fuse is reinstalled, the center position recognized by the steering angle sensor may not be the appropriate position. Therefore, it is necessary to perform steering sensor zero point calibration AFTER installing the D/C cut fuse during PDS.

Refer to the applicable Repair Manual for the steering sensor zero point calibration procedure:

- [Driving Method](#).
- [Techstream Method](#) (procedure 4).

2023 Sienna HV Pre-Delivery Service (PDS)

Front Wheel Opening Extension Pad Installation

The front wheel opening extension pad set (right and left front wheel opening extension pads) is loaded in the luggage compartment at the assembly plant to avoid damage in transit.

1. Remove the four self-tapping screws from the engine under cover (the self-tapping screws will be reused for the installation).

HINT

The removed self-tapping screws are reused when installing the front wheel opening extension pad.

Figure 3.

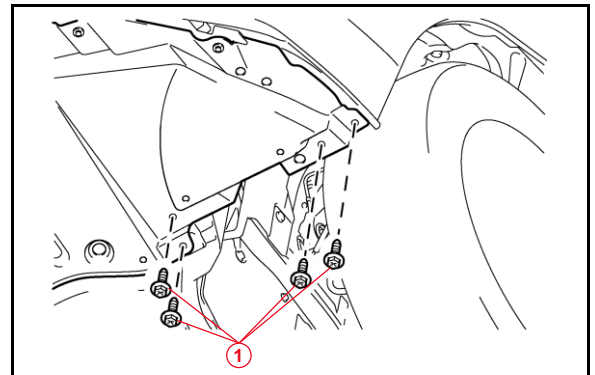

1	Self-tapping Screw
----------	---------------------------

2. Place the left-hand side front wheel opening extension pad on the installation position as shown and tighten the four self-tapping screws.

HINT

There is a distinguishable mark on each opening extension pad.

Figure 4.

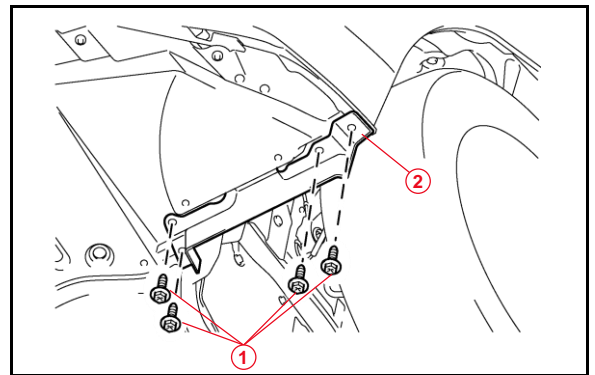

1	Self-tapping Screw
2	Front Wheel Opening Extension Pad

3. Repeat steps 1 and 2 for the right-hand side.

2023 Sienna HV Pre-Delivery Service (PDS)

Front License Plate and Mounting Bracket Installation

The front license plate bracket and four self-tapping screws are stored in the vehicle. Follow this procedure to install the front license plate bracket and front license plate in states where it is required by law.

1. Place the license plate bracket over the lower grille.

Figure 5.

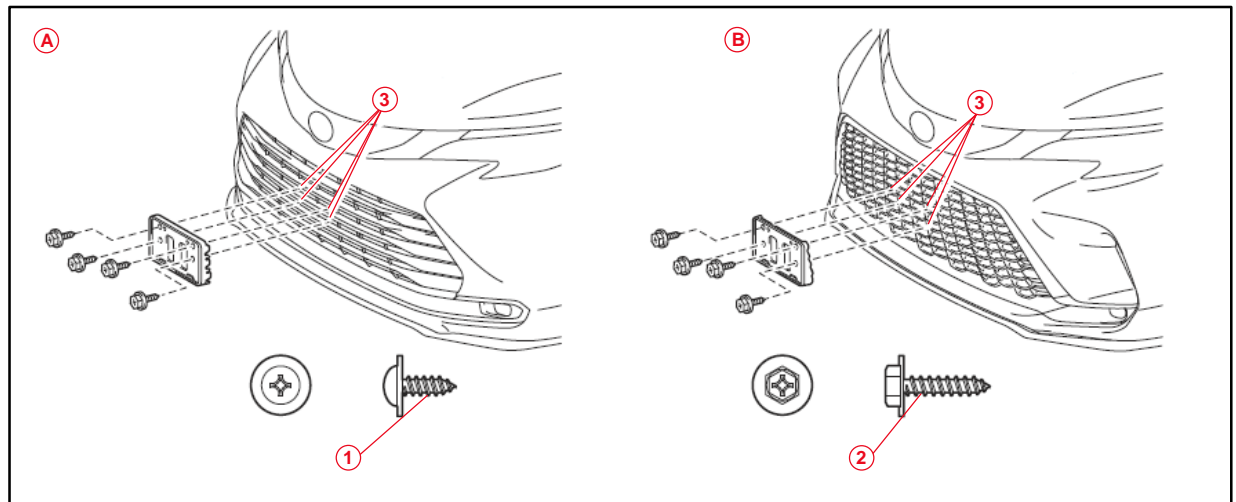

A	Type A
B	Type B
1	Short Self-tapping Screw

2	Long Self-tapping Screw
3	Dimple

2. Align the holes on the license plate bracket with the dimples on the front of the lower grille.
3. Install the four long self-tapping screws through the slotted and round holes on the license plate bracket and lower grille.
4. Align the holes of the license plate with the rounded holes of the license plate bracket.
5. Install two short self-tapping screws through the holes on the license plate bracket and license plate.

Figure 6.

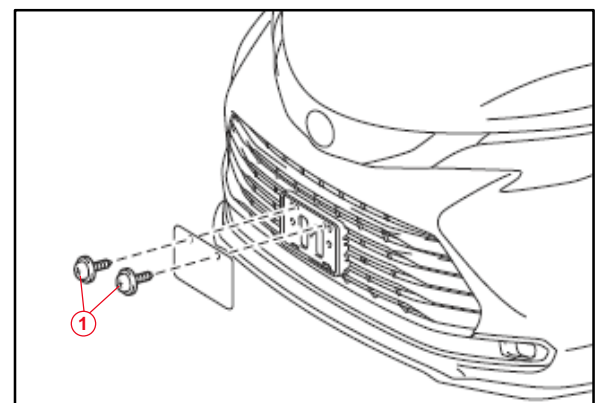

1	Short Self-tapping Screw
----------	--------------------------

2023 Sienna HV Pre-Delivery Service (PDS)

Installation of Rubber Body Plugs

1. Confirm the number of plugs in the glove box. If two plugs are present, perform substep 2A ONLY. If four plugs are present, perform substep 2A AND substep 2B.
2. Install the plugs according to the instructions below by confirming the number of plugs in the glove box.
 - A. Install two plugs in the rear side member hole or rocker inner hole as shown.
 - B. Install two plugs in the torque box hole or rocker inner hole as shown.

Figure 7.

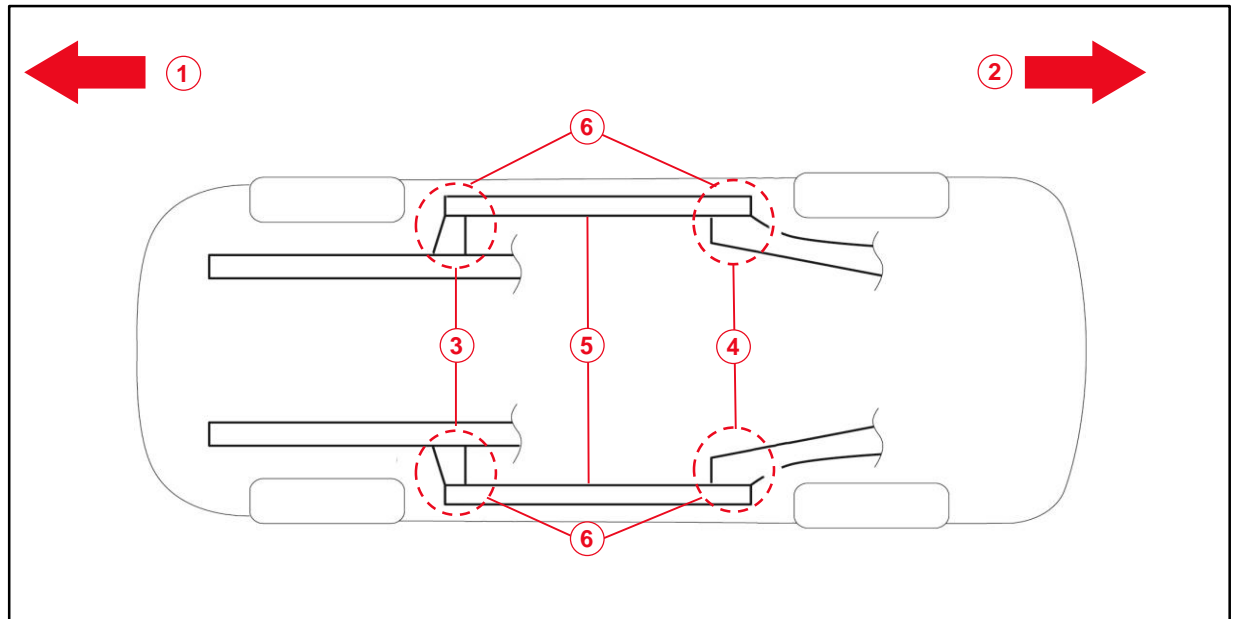

1	Front Side
2	Rear Side
3	Torque Box Hole or Rocker Inner Hole
4	Rear Side Member Hole or Rocker Inner Hole
5	Rocker Inner
6	Install Plug Here (if Applicable)

NOTICE

- The installation of these plugs is required to prevent rust.
- These plugs are stored in the glove box.
- The number of plugs may vary according to production locations in the same vehicle model.

2023 Sienna HV Pre-Delivery Service (PDS)

Tire Pressure Warning System (TPWS) Initialization

Refer to the applicable Repair Manual for the TPWS [initialization procedure](#). Note the spare tire does NOT have a TPWS sensor.

NOTE

To adjust the tire pressure correctly when the outside temperature is significantly colder than shop temperature, perform a Health Check using Techstream and select the compensation tire pressure checkbox. Compensation pressures will display on the Health Check results screen. Adjust the tire pressure when the tires are cold.

Dealer Contact Information for Call Dealer Head Unit Function

Refer to the *Multimedia System Owner's Manual* to [add dealer contact information](#).