



STAR ONLINE PUBLICATION



Case Number: S2108000279 REV. A

Release Date: January 2021

Symptom/Vehicle Issue: Rear View Mirror Camera Is Not Displaying In The Rearview Mirror

Customer Complaint/Technician Observation: Rear view camera display has no camera displaying after a recent service repair (see below image). Technician observes the rear view mirror has a camera icon warning lamp with a line through it.

Repair Procedure: The icon in the upper left corner of the digital mirror indicates no communication with the camera in the spoiler. Use the below test cable 99776-8 coaxial and circuit detail to isolate a connection of the J239 circuit to locate any issues from the mirror to the camera, Fig 1-3, pictures for routing and diagnostic aid.



Fig 1

This document does not authorize warranty repairs. This communication documents a record of past experiences. STAR Online does not provide any conclusions about what is wrong with the vehicle. Rather, it captures all previous cases known that appear to be similar or related to the vehicle symptom / condition. You are the expert, and you are responsible for deciding on the appropriate course of action.

Contact STAR Center, or your Technical Assistance Center Via TechCONNECT or eCONTACT ticket if no solution is found



STAR ONLINE PUBLICATION



Fig 2

This document does not authorize warranty repairs. This communication documents a record of past experiences. STAR Online does not provide any conclusions about what is wrong with the vehicle. Rather, it captures all previous cases known that appear to be similar or related to the vehicle symptom / condition. You are the expert, and you are responsible for deciding on the appropriate course of action.

Contact STAR Center, or your Technical Assistance Center Via TechCONNECT or eCONTACT ticket if no solution is found



STAR ONLINE PUBLICATION



Wiring Diagram - MIRROR - INTERIOR

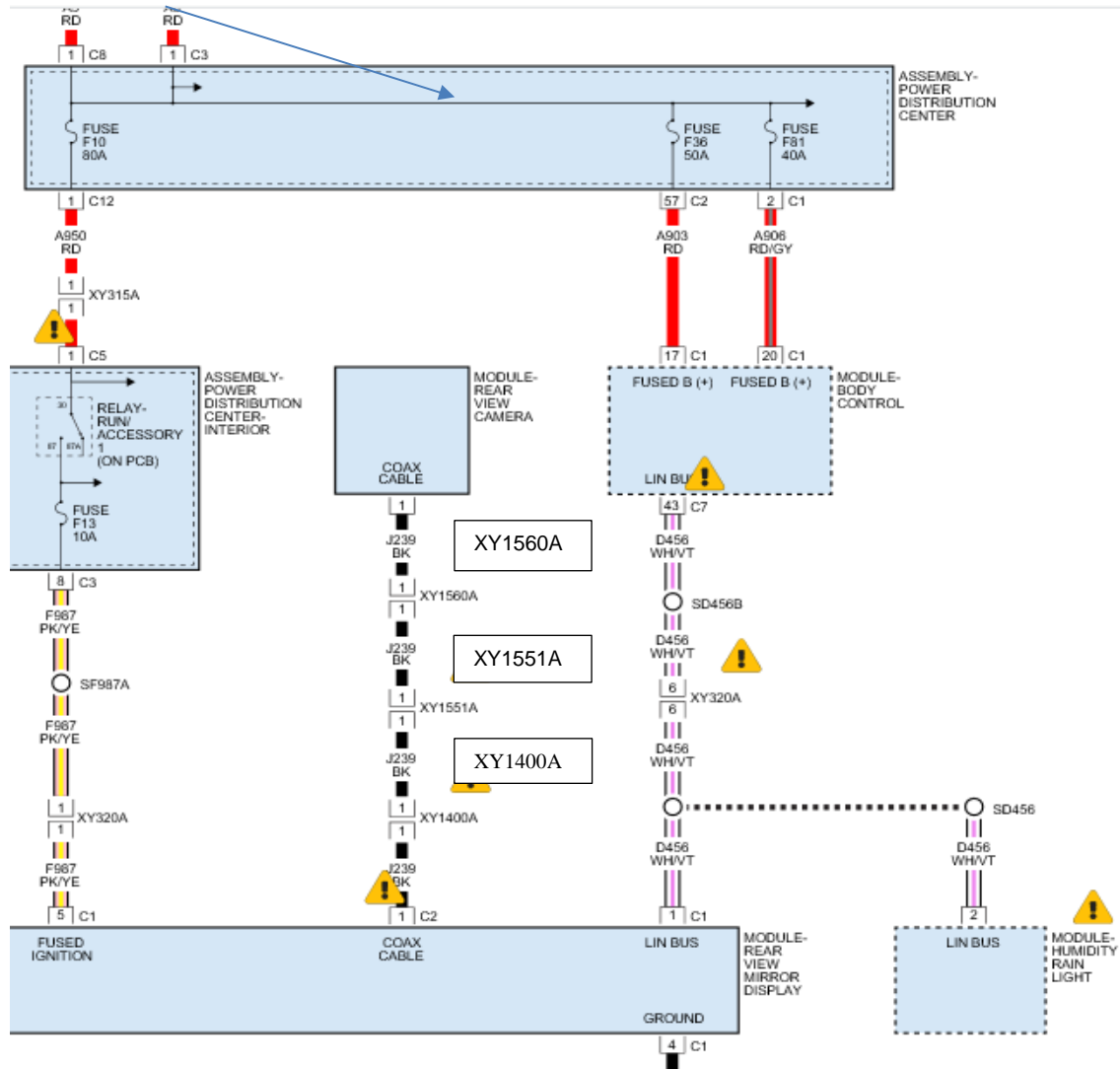

Fig 3

Pictures Below. Used as an aid for diagnostics, see below details.

This document does not authorize warranty repairs. This communication documents a record of past experiences. STAR Online does not provide any conclusions about what is wrong with the vehicle. Rather, it captures all previous cases known that appear to be similar or related to the vehicle symptom / condition. You are the expert, and you are responsible for deciding on the appropriate course of action.

Contact STAR Center, or your Technical Assistance Center Via TechCONNECT or eCONTACT ticket if no solution is found



STAR ONLINE PUBLICATION



Issue: rear view mirror service warning message cluster and rear view mirror upper left corner. No camera image rear view mirror. Vehicle options and function.

Diagnostic aid: use camera test cables and adapters, run test cable from mirror to tailgate connector. ******Also note tailgate must be closed when testing rear view mirror camera with test cable. Image will not display with tailgate open.**

Warning: follow one of two paths depending on vehicle camera code options. Because many WLs have BOTH options - rear cam view radio screen AND rear cam view on rear view mirror.

General advice need long coax camera test cable, and male to female connector adapters to diagnose this system. Remember to close tailgate or camera image will not display on rear view mirror.

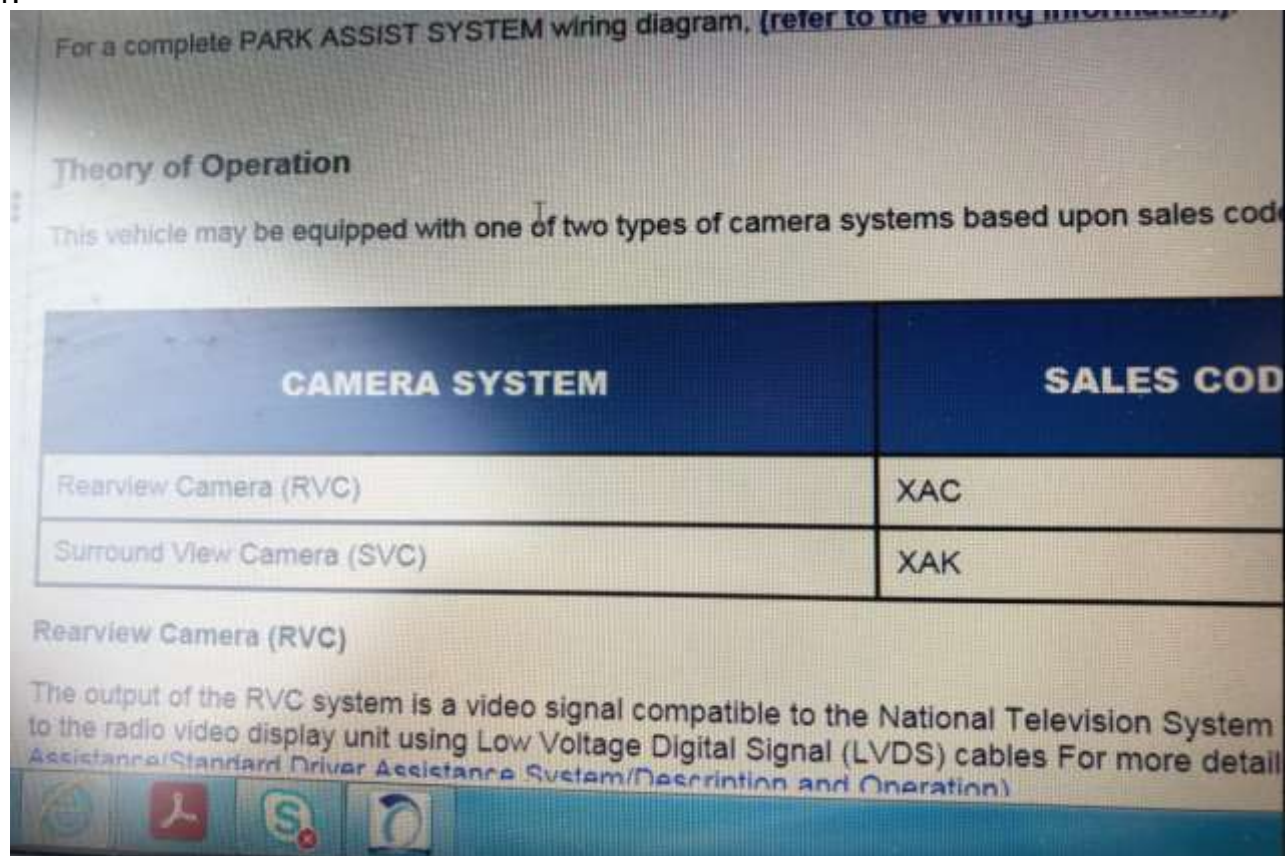

This document does not authorize warranty repairs. This communication documents a record of past experiences. STAR Online does not provide any conclusions about what is wrong with the vehicle. Rather, it captures all previous cases known that appear to be similar or related to the vehicle symptom / condition. You are the expert, and you are responsible for deciding on the appropriate course of action.

Contact STAR Center, or your Technical Assistance Center Via TechCONNECT or eCONTACT ticket if no solution is found



STAR ONLINE PUBLICATION



This document does not authorize warranty repairs. This communication documents a record of past experiences. STAR Online does not provide any conclusions about what is wrong with the vehicle. Rather, it captures all previous cases known that appear to be similar or related to the vehicle symptom / condition. You are the expert, and you are responsible for deciding on the appropriate course of action.

Contact STAR Center, or your Technical Assistance Center Via TechCONNECT or eCONTACT ticket if no solution is found



STAR ONLINE PUBLICATION



This document does not authorize warranty repairs. This communication documents a record of past experiences. STAR Online does not provide any conclusions about what is wrong with the vehicle. Rather, it captures all previous cases known that appear to be similar or related to the vehicle symptom / condition. You are the expert, and you are responsible for deciding on the appropriate course of action.

Contact STAR Center, or your Technical Assistance Center Via TechCONNECT or eCONTACT ticket if no solution is found



STAR ONLINE PUBLICATION



This document does not authorize warranty repairs. This communication documents a record of past experiences. STAR Online does not provide any conclusions about what is wrong with the vehicle. Rather, it captures all previous cases known that appear to be similar or related to the vehicle symptom / condition. You are the expert, and you are responsible for deciding on the appropriate course of action.

Contact STAR Center, or your Technical Assistance Center Via TechCONNECT or eCONTACT ticket if no solution is found



STAR ONLINE PUBLICATION



This document does not authorize warranty repairs. This communication documents a record of past experiences. STAR Online does not provide any conclusions about what is wrong with the vehicle. Rather, it captures all previous cases known that appear to be similar or related to the vehicle symptom / condition. You are the expert, and you are responsible for deciding on the appropriate course of action.

Contact STAR Center, or your Technical Assistance Center Via TechCONNECT or eCONTACT ticket if no solution is found