



QUALITY ACTION

CAMPAIGN BULLETIN Cowl Seam Seal Dealer Inventory

Reference: PMA11
Date: October 14, 2022

Attention: Dealer Principal, Sales, Service & Parts Managers

REVISED October 14, 2022
Please discard earlier versions of this bulletin.

The announcement from October 14, 2022 has been revised to include the following:

- The procedure in the Original Document for this Quality Action was a DRAFT VERSION of the procedure and was released in error. Disregard previous versions of this procedure.

Affected Models/Years:	Affected Population:	Dealer Inventory:	SERVICE COMM Activation date:	Stop Sale In Effect:
MY2022 Sentra (B18)	NA	418	October 7, 2022	YES

****** Dealer Announcement ******

Nissan is now updating the temporary hold on **418** specific model year 2022 Sentra vehicles identified in Service Comm to a dealer inventory quality action to apply sealant in the engine room. Due to a manufacturing issue, which has since been corrected, a seal was either improperly applied or is missing behind the left front strut tower in the cowl area of the engine room.

Affected vehicles are subject to stop sale and are either currently in dealer inventory or assigned and in transit to the dealer.

****** What Dealers Should Do ******

PLEASE FOLLOW THE ATTACHED INSTRUCTIONS:

1. Verify if vehicles are affected by this quality action using Service Comm or DBS National Service History – Open Campaigns I.D. **PMA11**
 - New vehicles in dealer inventory can also be identified using DBS (Sales-> Vehicle Inventory, and filter by Open Campaign).
 - Refer to NPSB 15-460 for additional information
 - **Some vehicles may still be in transit. Please continue to check newly arriving inventory for applicability.**

2. Please **do not drive, loan, sell or trade** the specific vehicles in dealer inventory subject to this quality action.
3. Use the attached procedure to remedy any vehicles affected by this quality action prior to sale.
4. The service department should submit the applicable warranty claim for the action performed to close the campaign in Service Comm and release the vehicle.

NISSAN NORTH AMERICA, INC.

Total Customer Satisfaction



PMA11 – 2022 SENTRA COWL SEAM SEAL

REQUIRED EQUIPMENT:



1. Seam Sealer: LORD Fusor 800DTM or 3M Urethane Seam Sealer #08368.

- LORD Fusor is available through Nissan Maintenance Advantage PN: 999MP9G000P
- Both LORD Fusor 800 DTM and 3M Urethane Seam Sealer #08368 can be purchased at Bodyshop Supply retailers or some Auto Parts Suppliers

2. Flat Brush: 1" size or #10.

- Can be purchased through Dollar type stores, large retail chain stores or craft stores

DISASSEMBLY:

1. Mark the location of the wiper blades on the windshield (Figure 1).

- Use a white or yellow china pencil/grease marker or equivalent

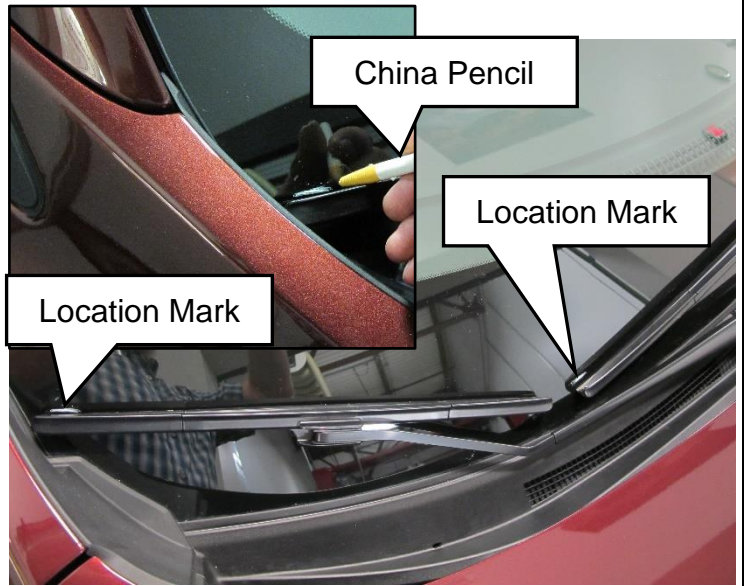

Figure 1

2. Open the hood.

- Secure hood prop rod to secure the hood (Figure 2)



Figure 2

3. Install fender protection to both fenders (Figure 3).



Figure 3

4. Remove wiper arm assemblies (Figures 4 and 5).

- Remove wiper nut caps
- Remove 14 mm wiper retainer nuts



Figure 4

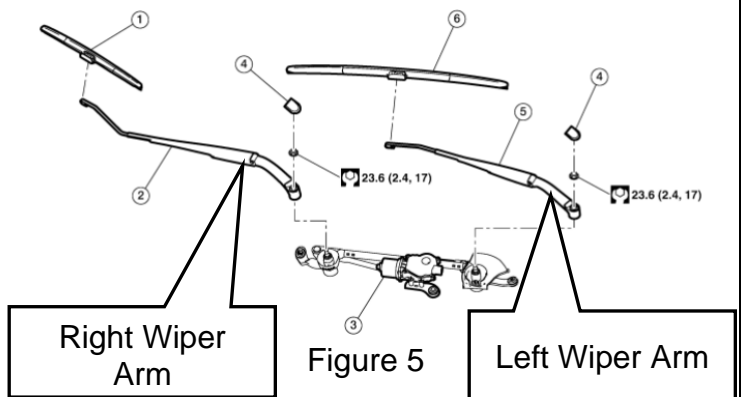

Right Wiper Arm

Figure 5

Left Wiper Arm

5. Remove cowl top side trim cover (LH) and (RH) (Figures 6, 7 and 8).

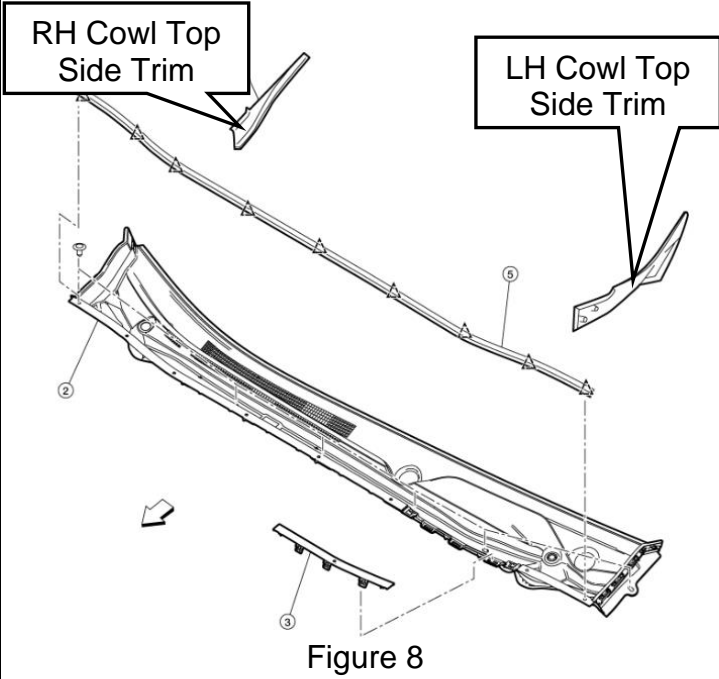

Figure 6



Figure 7

6. Remove cowl top assembly (Figure 9).

- Remove (6) retaining clips
- Gently remove the cowl top assembly making sure to not damage the windshield edge

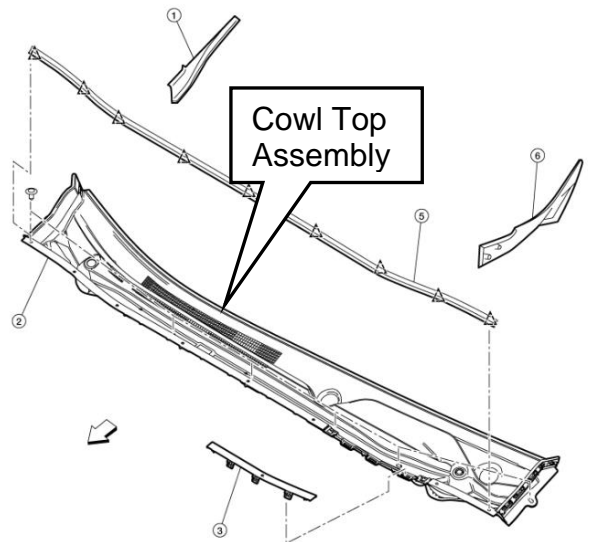

Figure 9

7. Disconnect wiper motor connector (Figure 10).

- Tuck the connector under the cowl as shown in Figure 11

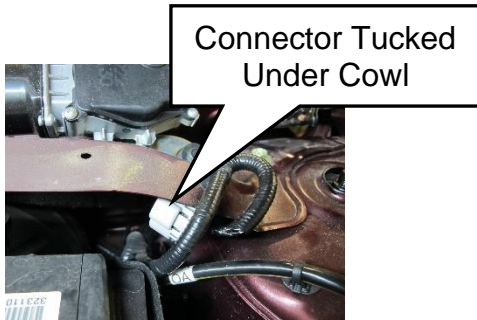

Figure 11

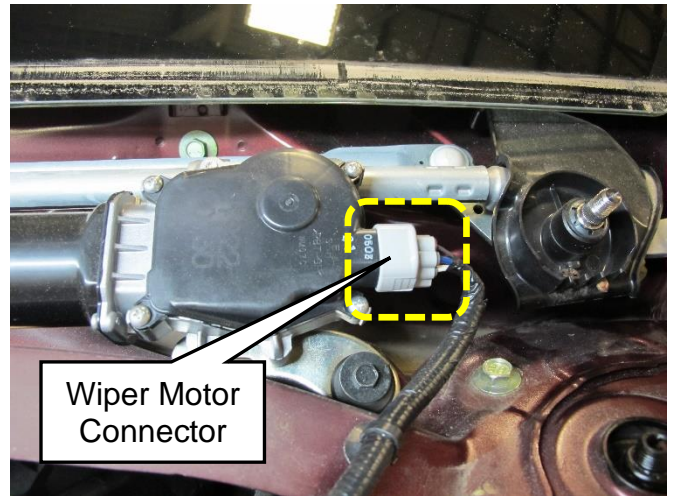

Figure 10

8. Remove wiper drive assembly.

- Remove the (3) 10mm retaining bolts as shown in Figure 12

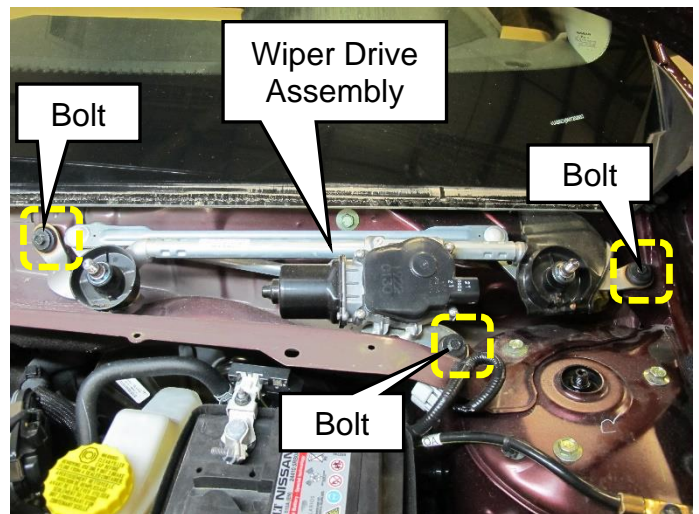

Figure 12

9. Locate the Driver's Side (Left Side) cowl joint seams to be resealed as shown in Figures 13 and 14.

- Figure 13 shows general area of driver's side strut/cowl area
- Figure 14 is seen by looking down the windshield toward the engine bay under the open hood

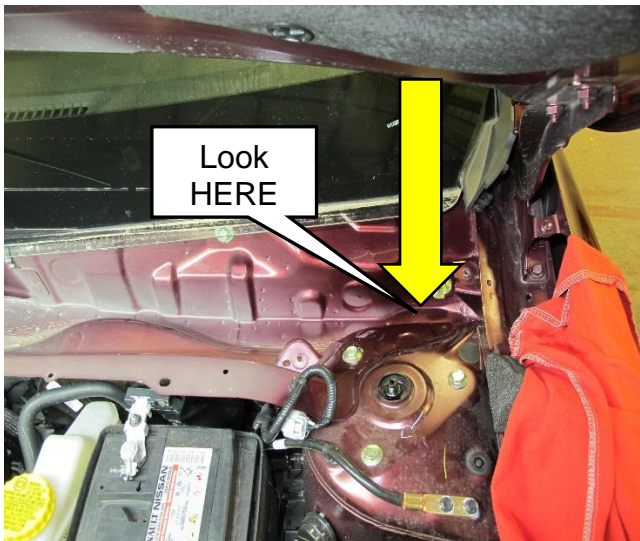

Figure 13

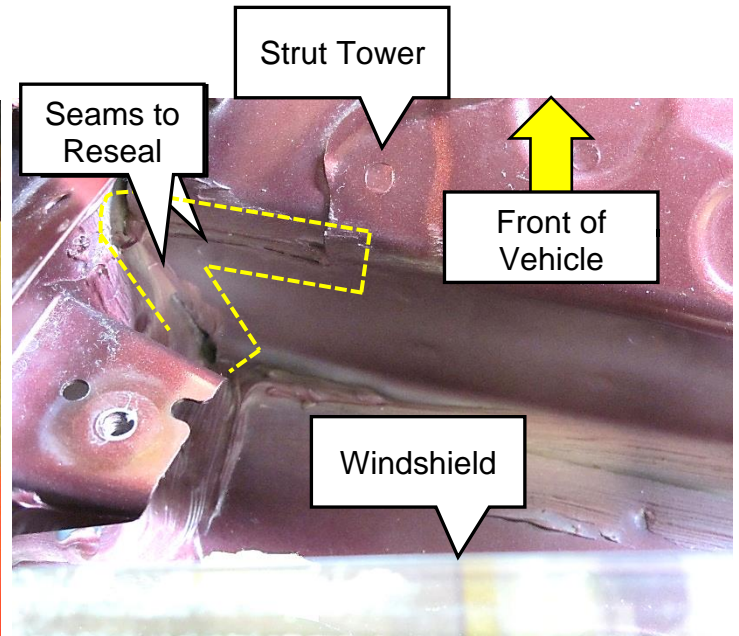

Figure 14

HINT: Use of a light source will assist with seam location.

10. Prepare the cowl area for application of the seam sealer.

- Using a clean lint free cloth and warm soapy water, clean the area to be resealed (Figure 15)
- Use compressed air to dry the area after cleaning

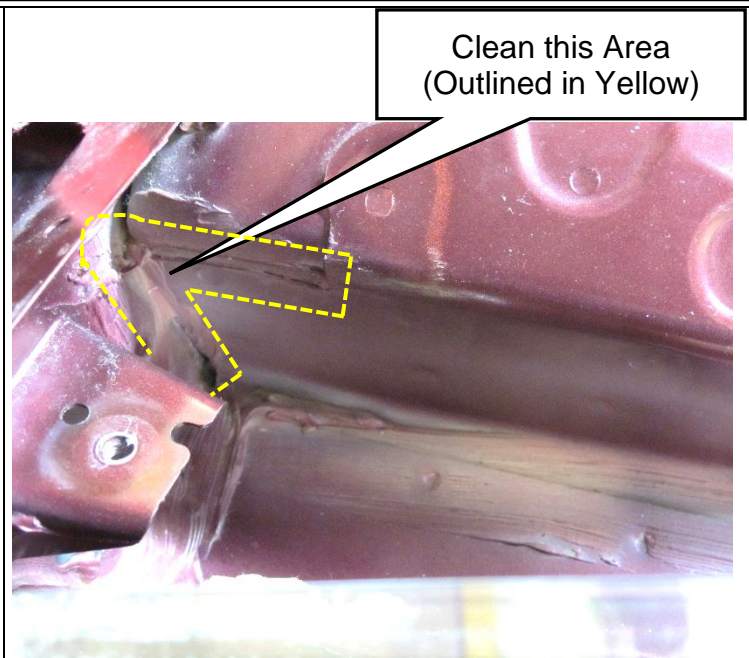

Figure 15

APPLY SEAM SEALER:

11. Prepare the seam sealer.

- If using 3M 08368 Urethane Seam Sealer, remove cartridge seal from the bottom of the cartridge tube
- Puncture the top end of the seam sealer cartridge tube (threaded outlet)
- Install applicator nozzle
- Insert the cartridge tube into an appropriate caulking gun
- Make sure to read and understand all instructions, precautions, and warnings on the cartridge tube of the seam sealer

12. Apply 1 inch of the seam sealer on the flat brush (Figure 16).

- Repeat this process until the seams listed in Step 13 below are completely sealed



Figure 16

13. Using the brush with the seam sealer on it, apply the seam sealer to the joint seams identified in Figure 19.

- Use brush angle of 30-45 degrees to smooth the sealer (Figure 17)

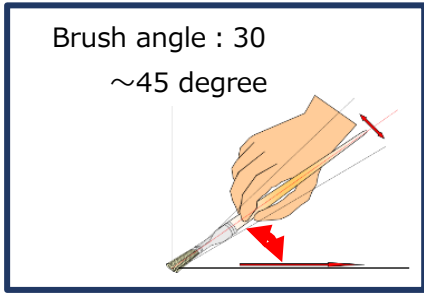

Figure 17

- Brush the seam sealer into the joint seams as shown in Figure 18

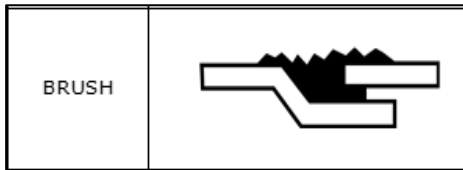

Figure 18

14. Figure 20 shows the cowl area after joint seams have been resealed with the brushed on seam sealer.

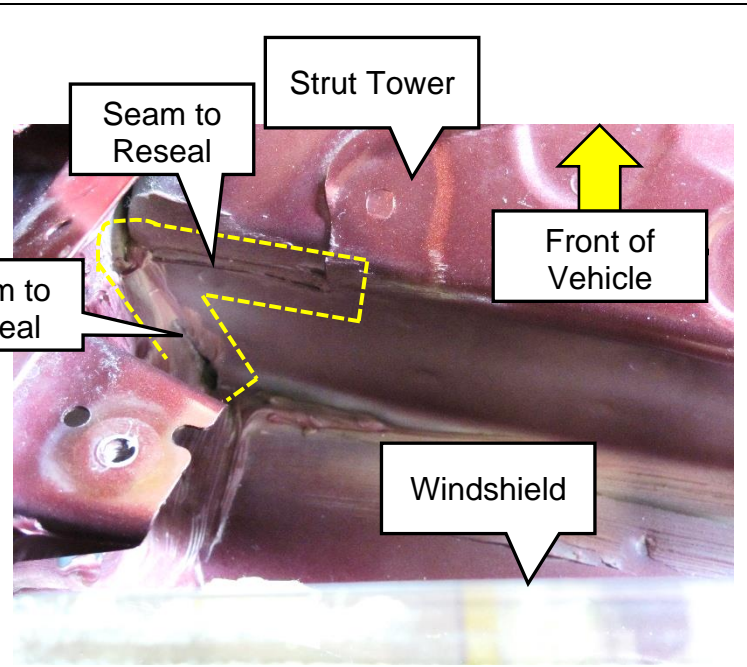

Figure 19



Figure 20

15. Once the seam sealer application is completed, allow the sealer to dry for 30 minutes.



REASSEMBLY:

16. Install wiper drive assembly.

- Tighten the wiper drive assembly bolts to the sequence shown in Figure 21 and torque specification shown below
- Torque the (3) 10 mm retaining bolts to 8 N•m (0.82 kg-m, **71 in-lb**)

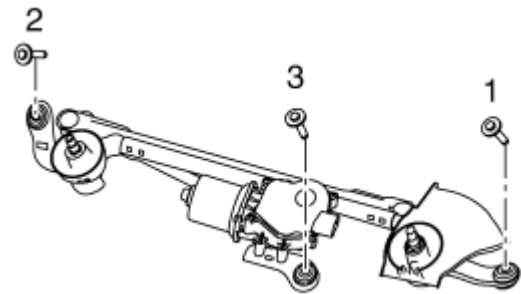

Figure 21

17. Install the wiper motor connector (Figure 22).

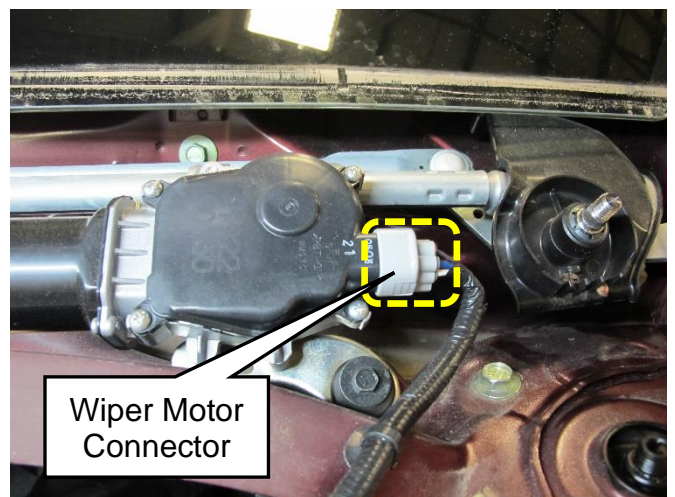
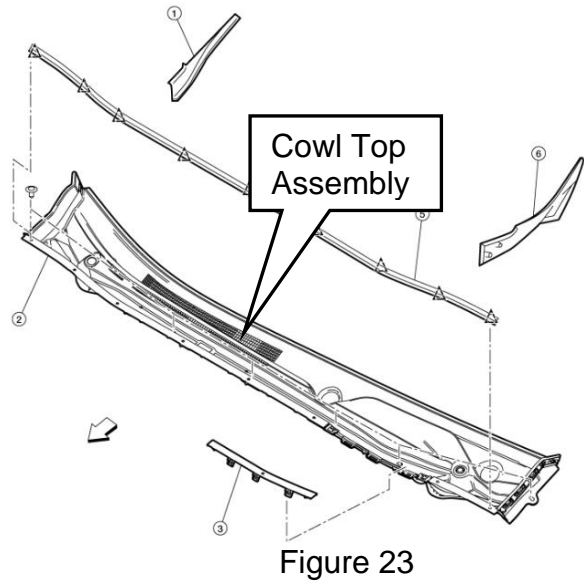

Figure 22

18. Install cowl top assembly (Figure 23).

IMPORTANT: Prior to cowl top installation, use a clean damp cloth to clean the joint between the cowl top cover and the windshield.

- Carefully slide the cowl top onto the bottom of the windshield using care to not damage the (13) positioning clips that nest under the windshield edge
- Install the (6) retaining clips



19. Install cowl top side trim cover (RH) and (LH) (Figures 24 and 25).



20. Install wiper arm assemblies (Figures 26 and 27).

- Position both wiper blades to the location marks on the windshield
- Install the 14 mm wiper retainer nuts
- Torque the wiper retaining nuts to 23.6 N•m (2.4 kg-m, **17 ft-lb**)
- Install wiper nut caps

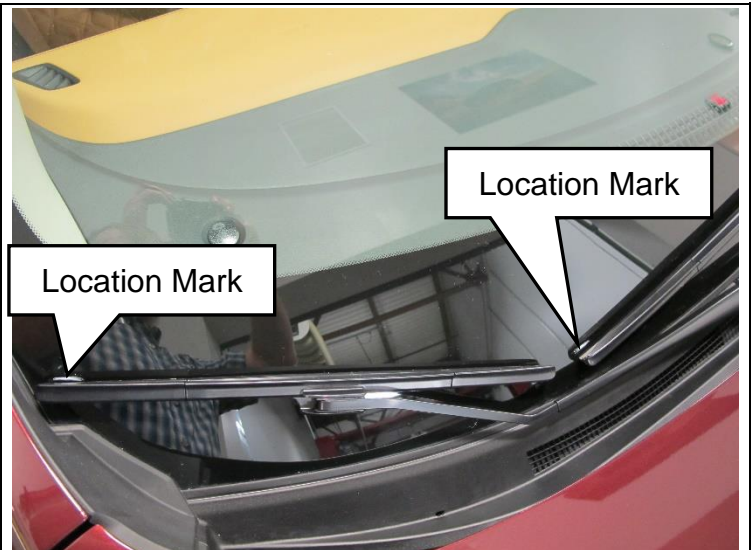

Figure 26

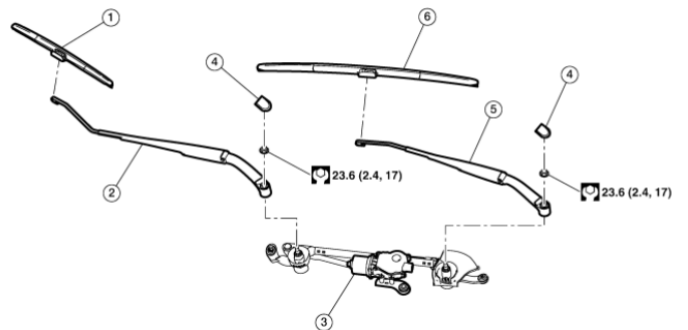

Figure 27

21. Remove the fender protection.

22. Close the hood.

- Stow the hood prop rod on retainer clip

23. Verify wiper blades operate correctly.

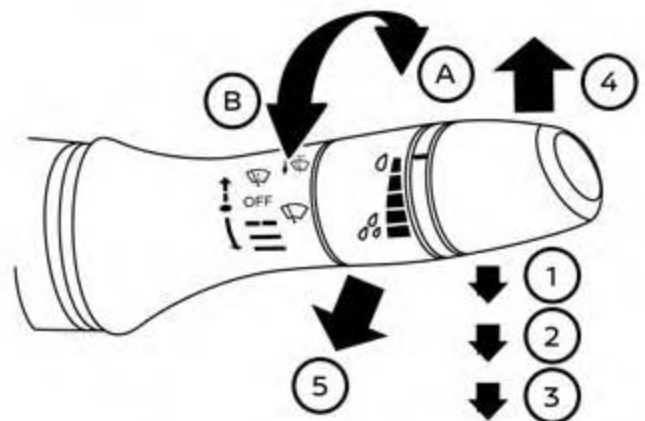

Figure 28

EXPENSE CODE

EXPENSE CODE	DESCRIPTION	MAX AMOUNT
101*	LORD Fusor 800DTM <u>or</u> 3M #08368 Seam Sealer <u>and</u> Flat Brush*	\$66.00

*** LORD Fusor is available through Nissan Maintenance Advantage PN: 999MP9G000P.**

NOTE:

- **3M Urethane Seam Sealer #08368 can be purchased at Bodyshop Supply retailers or some Auto Parts Suppliers**
- **The flat brush can be purchased through Dollar type stores, large retail chain stores or craft stores**
- **MAX AMOUNT includes one of the above listed seam sealers, a flat brush, local and state tax**

CLAIMS INFORMATION

Submit a "CM" line claim using the following claims coding:

Campaign ("CM") ID	Description:	Op Code	FRT
PMA11	Reseal Driver Side Cowl Seam	PMA110	0.6 Hr