



Service Bulletin

Bulletin No.: 22-NA-089

Date: September, 2022

TECHNICAL

Subject: Intermittent Click Noise at Front of Vehicle, ABS, Traction Control System (TCS)/ Stabilitrak Lamps May Illuminate Intermittently and/or Deactivate for Ignition Cycle - DTC P215B, C0035-C0051 Set

Brand:	Model:	Model Year:		VIN:		Engine:	Transmission:
		from	to	from	to		
Chevrolet	Bolt EV	2017	2019	—	—	—	—

Involved Region or Country	North America, Middle East, GM Korea Company		
Condition	<p>Some customers may comment on one or more of the following conditions: Note: The systems in question may deactivated/shut off for that ignition cycle.</p> <ul style="list-style-type: none"> • Hearing an intermittent click noise in the front of vehicle. • ABS, TCS and/or Stabilitrak system lamps illuminate intermittently. <p>Technicians may find one or more of the following DTCs set:</p> <ul style="list-style-type: none"> • P215B • C0035-C0051 		
Cause			
Correction	<p style="text-align: right;">5317523</p> <p>This condition may be caused by fracturing of the front wheel drive shaft anti-click washer (1) and possible collateral damage to the ABS wheel speed sensor (WSS).</p> <p>Note: In cases where the condition is verified on both sides of the vehicle, replace the anti-click washer on BOTH sides.</p> <p>Upon verifying the condition, replace the anti-click washer with new part number shown below on the affected half shaft(s), then inspect the wheel speed sensor on that side(s).</p> <p>Note: If DTC P215B ever sets on the vehicle, replace the wheel speed sensor.</p>		

Service Procedure

Important: Service agents must comply with all International, Federal, State, Provincial, and/or Local laws applicable to the activities it performs under this bulletin, including but not limited to handling, deploying, preparing, classifying, packaging, marking, labeling, and shipping dangerous goods. In the event of a conflict between the procedures set forth in this bulletin and the laws that apply to your dealership, you must follow those applicable laws.

Antilock Brake System:

Important: Once removed, the drive shaft nut cannot be reused. Follow the recommendations in SI for this and any other fastener replacement.

1. Separate the lower control arm from the steering knuckle. Refer to *Front Wheel Drive Shaft Replacement* in the Service Manual.

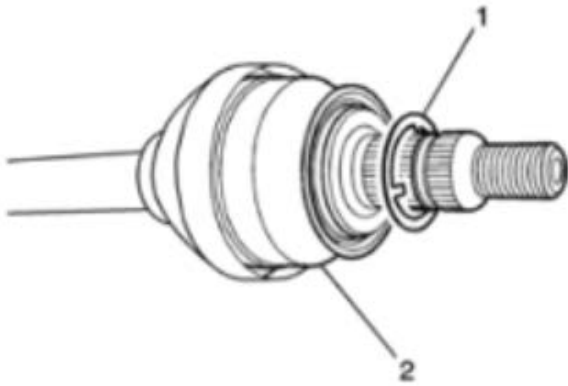

5317528

2. Remove the anti-click washer (1) from the outboard joint of the half shaft (2) and discard. Then replace the anti-click washer with new part number shown below.
3. If affected, repeat steps #1 and #2 on the opposite side.

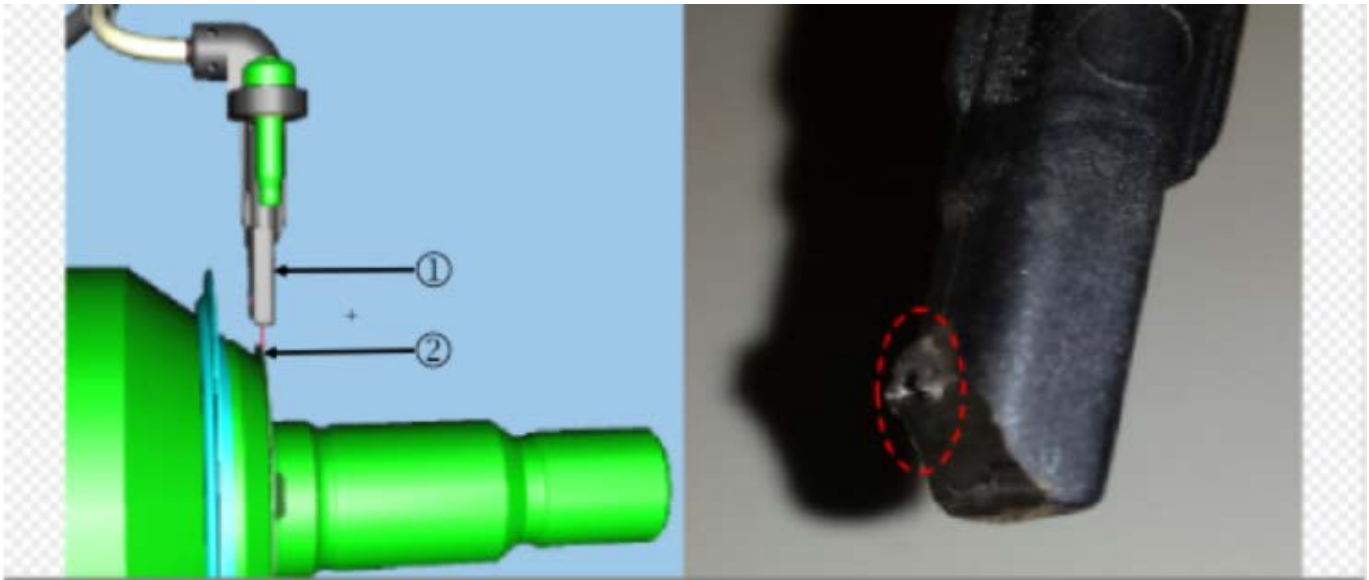

5317529

Note: The example above depicts the wheel speed sensor (WSS) (1) directly in-line with the anti-click washer (2) on the outboard joint of the half shaft.

4. Inspect the WSS on either/both affected side(s) for possible damage.
 - If no damage is found, reinstall the lower control to the steering knuckle, and no further repairs are necessary.
 - If the WSS is found to be damaged (as shown circled in the graphic above), continue ahead to step # 5.

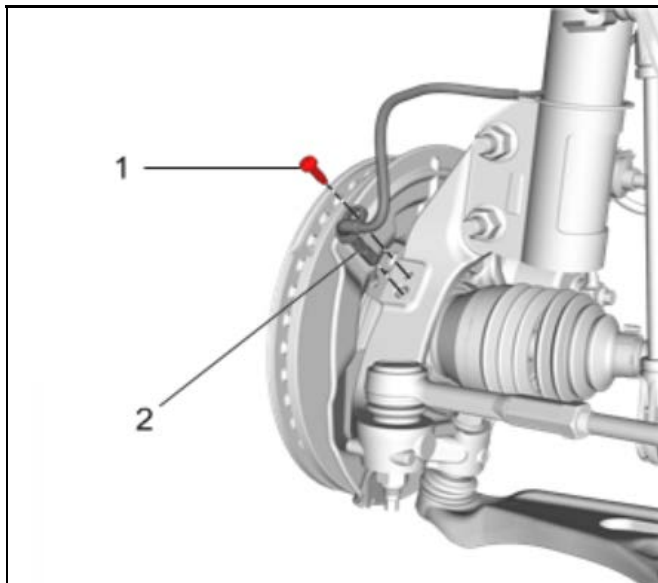

4514607

5. Replace any damaged front WSS (2). Refer to *Front Wheel Speed Sensor Replacement* in the Service Manual.
6. Install the lower control arm to the steering knuckle. Refer to- *Front Wheel Drive Shaft Replacement* in the Service Manual.

Parts Information

Use the vehicle identification number (VIN), SI, and the GM Electronic Parts Catalog to determine the proper part to order.

Causal Part	Description	Part Number	Qty
X	WASHER – FRT WHL DRV SHF (57 MM OD)	42754282	1, or 2, if required
N/A	NUT – FRT WHL DRV SHF (M22 X 1.5)	13208079	
N/A	SENSOR – FRT WHL SPD	42768982	

Warranty Information

For vehicles repaired under the Powertrain coverage, use the following labor operation. Reference the Applicable Warranties section of Investigate Vehicle History (IVH) for coverage information.

Labor Operation	Description	Labor Time
3087328*	REPLACE FRONT WHEEL DRIVE SHAFT WASHER (ONE SIDE)	1.1 hrs
Add	REPLACE WHEEL SPEED SENSOR (ONE SIDE)	0.2 hr
Add	REPLACE FRONT WHEEL DRIVE SHAFT WASHER (OTHER SIDE)	0.7 hr
Add	REPLACE WHEEL SPEED SENSOR (OTHER SIDE)	0.2 hr

*This is a unique Labor Operation for bulletin use only.

Version	2
Modified	Released May 25, 2022 Revised September 16, 2022 – Added an Important statement to the beginning of the Service Procedure, removed the Important statement between steps 1 and 2, added a line to step 2 and removed a line from step 4.

