

WNK7 - Replace Connectors for Antenna Cable (Workshop Campaign)

Revision: This bulletin replaces bulletin Group 9 149/22 WNK7, dated September 12, 2022.

Model Series: **Taycan**

Model Year: **As of 2020 up to 2022**

Concerns: **Antenna cable plug connections**

Information: **Due to a temporary manufacturing defect, there is a possibility of moisture penetration into the electric plug connections for the antenna cables on the affected vehicles.**

A corroded plug connection can cause increased contact resistances and signal faults over the service life of the vehicle.

Action required: Replace the connector housings of the electric plug connections assigned to the respective vehicle according to the campaign scope and repair the plug connections if necessary.

Affected Vehicles: Only vehicles assigned to the campaign (see also PCSS Vehicle Information).



Information

Due to the equipment variant and the differently affected batches, the affected vehicles are assigned to one scope (1 to 3).

Due to the failure rate, it is expected that more than 90% of the vehicles can be handled via this scope.

With regard to the remaining max. 10%, there is a possibility that one or up to three plug connections may show corrosion due to moisture penetration and will therefore have to be repaired (scope 4-14).

To find out which campaign scope is assigned to the respective vehicle for **replacing the plug connections**, see PCSS Vehicle Information.

Scope:	Action required:					
	Replacing connector housing for front camera	Replacing connector housing for LTE antenna	Replacing connector housing for reversing camera	Replacing front camera. front camera antenna cable & repair plug connection	Replace LTE antenna cable & repair plug connection	Replace reversing camera antenna cable & repair plug connection
1	■	■	■			
2	■	■				
3			■			
4		■	■	■		
5	■		■		■	
6			■	■	■	
7	■	■				■
8				■	■	■
9		■		■		
10				■	■	
11	■				■	
12						■
13		■		■		■
14	■				■	■

Parts required



Information

Ordering and invoicing process for antenna cable connectors

The parts required for replacing the connector housings for antenna cables can be ordered from the **TKR Automotive GmbH online shop**.

The link for the online shop is:

<http://www.tkr-connector.com>

For more information about using the online shop, see: Video in attachment for campaign WNK7 in the PPN document.

There are various search functions to help you identify the repair kit "**Antenna cable plug connections**", e.g. by entering the campaign number or using a graphic search function.

Order the required repair kits individually as required or as a collective order using the ordering process for the TKR Automotive GmbH online shop.

Order rate:

Please initially order only 80% of the repair kits 1-3 you need.

Due to the expected failure rate of corroded plug connections, please order **only approx. 8% of repair kits 4-5 and less than 1% of repair kit 6**.

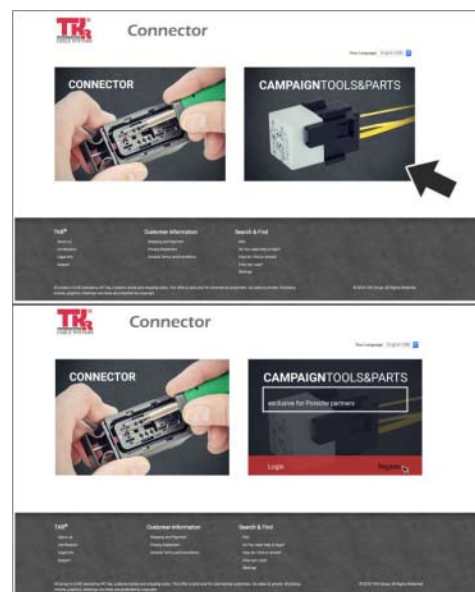

TKR Automotive GmbH online shop

Please read the following information about processing the campaign:

- For warranty processing, the **Part Nos. WNK70000001 WNK70000006** with the designation "WNK7 Repair kit for plug connections" can be invoiced as an **additional part** in the warranty claim. Amount individually according to the repair kit.
- For a collective order, the shipping costs may only be invoiced once for the first vehicle during warranty processing by specifying **Part No. WNK70000008** with the designation "Shipping costs" as an **additional part** and using the amount as per invoice. For all other vehicles, on which parts from this collective order will be used, only the repair kit, expendable items and labor time are to be invoiced in the warranty claim.
- Document a copy of the invoice in the warranty claim.

Parts Info: The **WNK7 connector housing** repair kits comprise the following individual parts:

- 1 – Connector housing for LTE, front camera and reversing camera
- 2 – Connector housing for LTE, front camera
- 3 – Connector housing for reversing camera

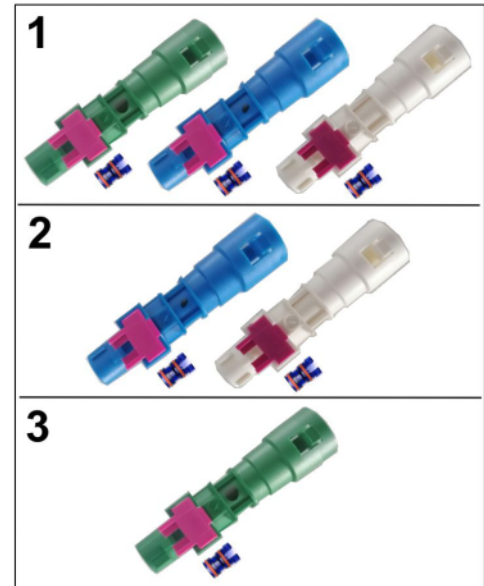

Connector housing repair kits

Repair kit:	Overview of parts:			Number	Amount
	Connector housing (blue) front camera	Connector housing (white) LTE antenna	Connector housing (green) reversing camera		
WNK7100000 01	■	■	■	1 piece	\$31.88
WNK7100000 02	■	■		1 piece	\$31.25
WNK7100000 03			■	1 piece	\$30.63



Information

Ordering and invoicing process for repair parts for repairing the plug connections

We assume that a **repair of the plug connections (scope 4-14)** is only necessary in max. 10% of the vehicles affected by the campaign.

To order the spare parts required for repairing the plug connections (scope 4-14), the following procedure MUST be observed:

- We generally assume that, if a connector is corroded, it is sufficient to repair the connection on the body with a connector including coupler. For this purpose, cut the affected antenna cable as close as possible to the old coupler/connector and crimp it using a new coupler according to the instructions in repair kit VAS6720.

- The suitable couplers/connectors from the repair range in the kit for antenna lines (VAS 6720) may be used if they comply with the specifications set out in the TI.
- If connectors/couplers of add-on parts (front/rear bumper) are corroded, the complete antenna cable must be replaced. The connector generations are also **changed here from the 420 series to the 5QF series**.

The **WNK7 plug connections and antenna cables** repair kit comprises the following individual parts:

Repair set	Designation	Number
4	Cable seal (red)	1 piece
	Connector housing (blue)	1 piece
	Inner conductor (RG174)	4 pieces
	Connector, straight (RG174)	1 piece
	Crimping sleeve (RG174)	1 piece
	Plastic cap	1 piece
	Front camera antenna cable	1 piece
5	Cable seal (blue)	1 piece
	Connector housing (white)	1 piece
	Inner conductor (RTK031)	4 pieces
	Connector, straight (RTK031)	1 piece
	Crimping sleeve (RTK031)	1 piece
	Plastic cap	1 piece
	LTE antenna cable	1 piece
6	Cable seal (red)	1 piece
	Connector housing (blue)	1 piece
	Inner conductor (RG174)	4 pieces
	Coupler, straight (RG174)	1 piece
	Crimping sleeve (RG174)	1 piece
	Plastic cap	1 piece
	Antenna cable for reversing camera	1 piece

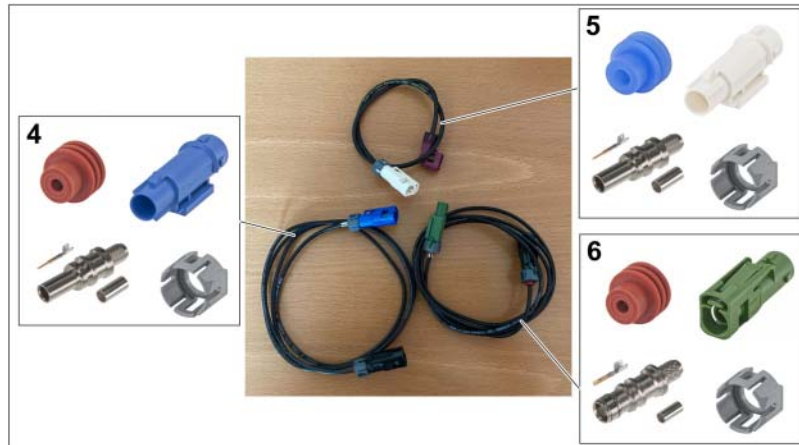

Repair kits for plug connections and antenna cables

- 4 – Antenna cable repair kit for front camera & plug connection (blue)
- 5 – Repair kit for LTE antenna cable & plug connection (white)
- 6 – Antenna cable repair kit for reversing camera - & plug connection (green)

Repair kit:	Overview of parts:			Number	Amount
	Front camera antenna cable & plug connection (blue)	LTE antenna cable & plug connection (white)	Antenna cable for reversing camera & plug connection (green)		
WNK71000004	■			1 piece	\$58.13
WNK71000005		■		1 piece	\$58.13
WNK71000006			■	1 piece	\$58.13

Expendable items:

Required materials (usually already available at the Porsche dealer):

- Fabric adhesive tape (fleece)
- Tie-wrap

For warranty processing, the Part No. **WNK70000007** with the designation “Expendable items” can be invoiced as an **additional part** in the warranty claim. Maximum cost: \$2.50.

Required tools

Tools:

- Torque wrench, 40 – 200 Nm (30 – 148 ftlb.), e.g. **V.A.G 1332A - Torque wrench, 40 – 200 Nm (30 – 148 ftlb.)** or equivalent

- Torque wrench, 2 – 10 Nm (1.5 – 7.5 ftlb.), e.g. **VAG 1783 Torque wrench, 2-10 Nm (1.5-7.5 ftlb.)** or equivalent
- Torque wrench, 6 – 50 Nm (4.5 – 37 ftlb.), e.g. **VAG 1331A Torque wrench, 6-50 Nm (4.5-37 ftlb.)** or equivalent
- **VAS 6720 - Antenna line repair set** (only if required)

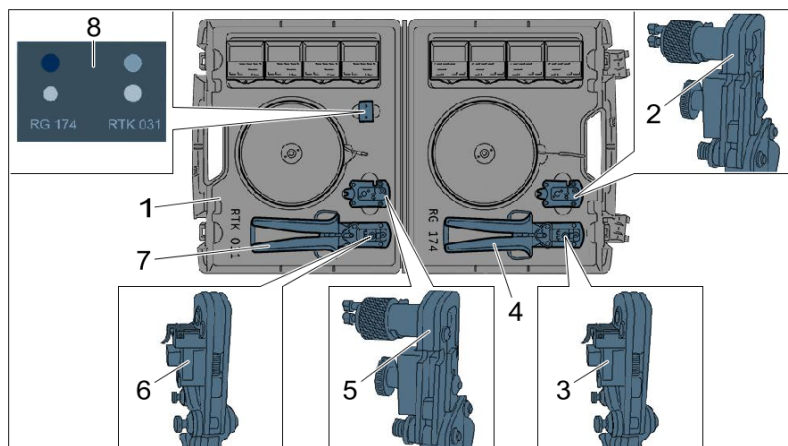

Antenna line repair set

- 1 – **VAS 6720 - Antenna line repair set**
- 2 – **VAS 6720/3** Wire stripping tool RG 174.
- 3 – **VAS 6720/4** Crimping tool RG 174
- 4 – Crimping pliers
- 5 – **VAS 6720/1** Wire stripping tool RTK-031
- 6 – **VAS 6720/2** Crimping tool RTK-031
- 7 – Crimping pliers
- 8 – **VAS 6720/5** Gauge

Please see <https://ppn.porsche.com/portal/docs/DOC-327999> for VAS 6720 tool location.

Replacing connector housing for antenna cable at front and rear (scope 1)

Work

Preparatory work

Procedure:

- 1 Remove front left wheel housing liner, (front section). ⇒ *Workshop Manual '50561903 Removing and installing rear wheel housing liner (front section)'*
- 2 Remove rear left wheel housing liner. ⇒ *Workshop Manual '536919 Removing and installing rear wheel housing liner'*



Information

The number of electric plug connections can vary depending on equipment.

- 3 **Replacing front connector housing (blue/white)**

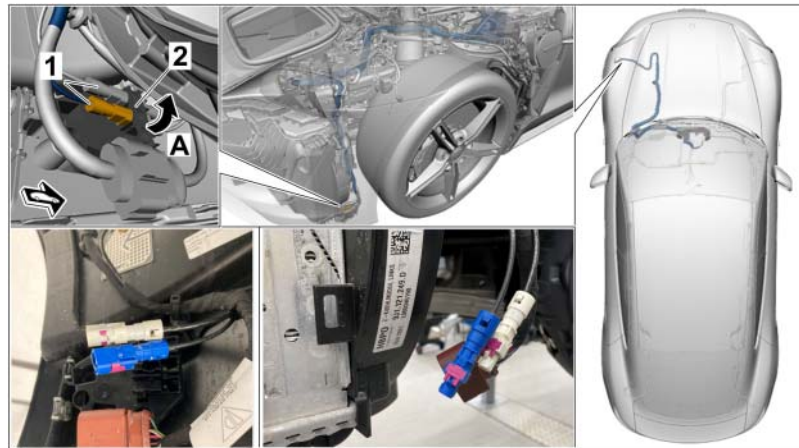

Replacing front connector housing

3.1 Unclip plug connections ⇒ *Replacing front connector housing -1-* from ⇒ *Replacing front connector housing -2-* the holder ⇒ *Replacing front connector housing -arrow A-*.

3.2 Release electric plug connections and disconnect them.

3.3 Check whether the coupler connection ⇒ *Checking connector -Arrow-* has visible traces of corrosion on both plug connections.

If no traces of corrosion are visible on the coupler, **continue with Step 3.4**.

If traces of corrosion are visible on the coupler, document this by taking a photograph using a digital camera and repair the antenna cable. For this purpose, **continue with** ⇒ *Replace antenna cable and repair plug connection (scope 4-14)*.

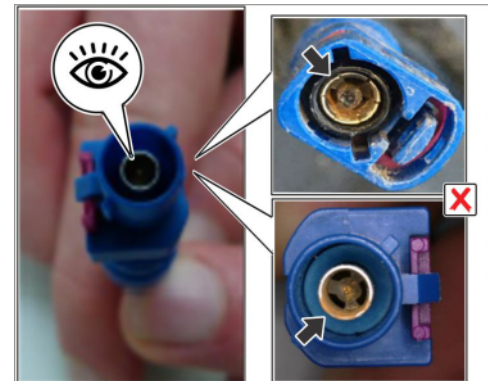

Checking connector

- 3.4 Replace connector housing (on body).
 - 3.4.1 Lever off secondary lock on the connector housing ⇒ *Disassemble connector housing -1-* using a small screwdriver ⇒ *Disassemble connector housing -arrow A-*.
 - 3.4.2 Lever off primary lock ⇒ *Disassemble connector housing -Arrow B-* and ⇒ *Disassemble connector housing -Arrow C-* pull connector housing out of the antenna cable.

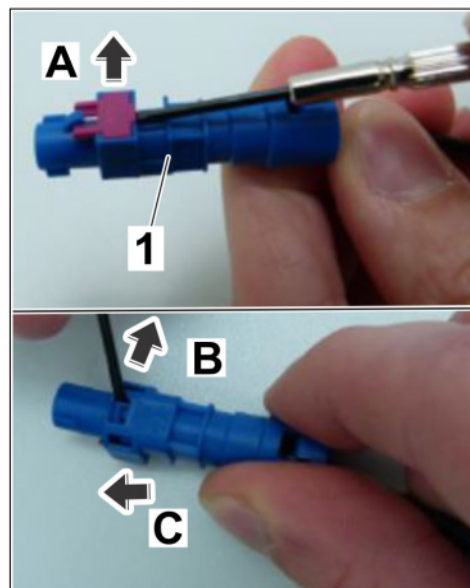

Disassemble connector housing

- 3.4.3 Dispose of ⇒ *Replacing connector housing -1-* connector housing.
- 3.4.4 Pull off sleeve ⇒ *Replacing connector housing -2-* on the coupler ⇒ *Replacing connector housing -3-* and dispose of it.
- 3.4.5 Push in the new sleeve ⇒ *Replacing connector housing -2-* on the coupler ⇒ *Replacing connector housing -3-* up to the anchor block ⇒ *Replacing connector housing -arrow-*.

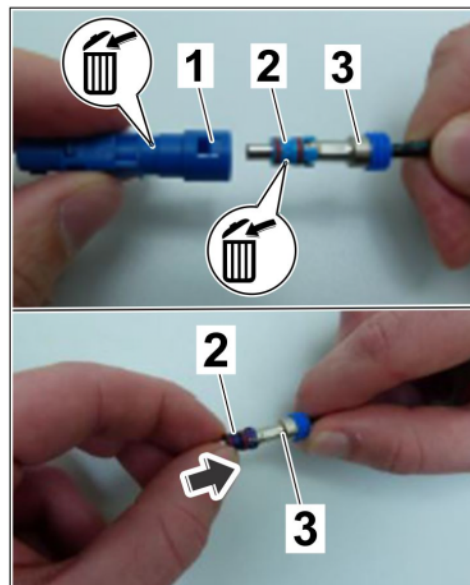

Replacing connector housing

3.4.6 Push in new connector housing (420 series) ⇒ *Assemble connector housing -1-* on the antenna cable ⇒ *Assemble connector housing -1-* until it engages securely ⇒ *Assemble connector housing -Arrows A-*.

3.4.7 Press in secondary lock ⇒ *Assemble connector housing -Arrow B-* and ensure that the antenna cable is locked correctly by pulling.

3.5 Check and replace second plug connection as described in Steps 3.3 to 3.4.

3.6 Connect both plug connections and fasten them in the holder again.

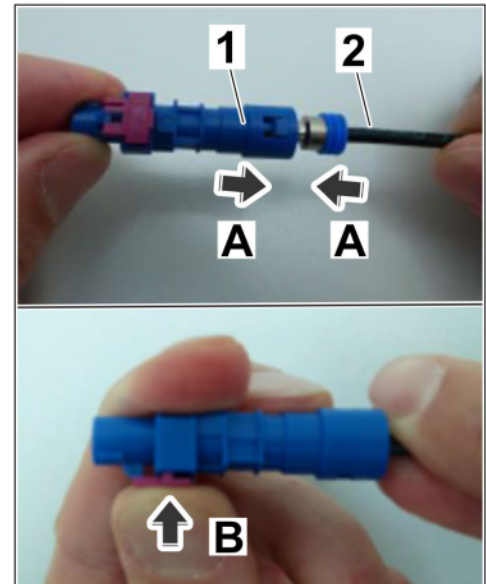

Assemble connector housing

4 Replacing rear connector housing (green)

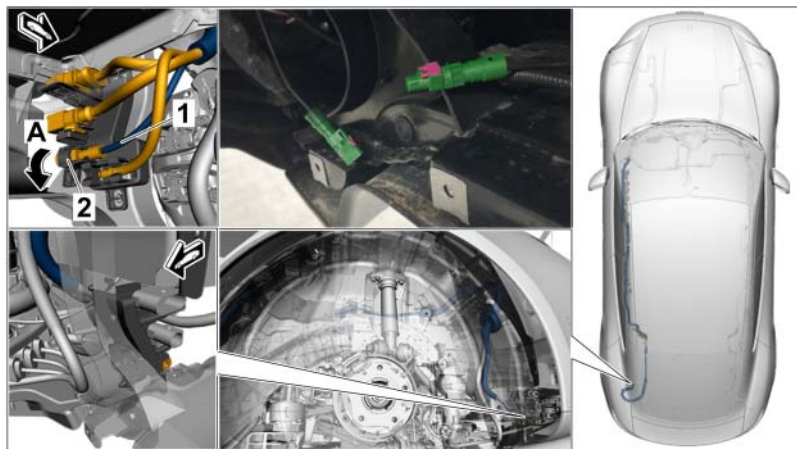

Replacing rear connector housing

4.1 Unclip ⇒ *Replacing rear connector housing -1-* plug connection ⇒ *Replacing rear connector housing -2-* from the holder ⇒ *Replacing rear connector housing -arrow A-*.

4.2 Release plug connection and disconnect it.

4.3 Check and replace connector housing (rear bumper) as described in Steps 3.3 to 3.4.

If traces of corrosion are visible on the coupler, document this by taking a photograph using a digital camera and repair the antenna cable. For this purpose, **continue with** ⇒ *Replace antenna cable and repair plug connection (scope 4-14)*.

5 Connect both plug connections and fasten them in the holder again.

Concluding work

- 6 Install front left wheel housing liner (front section). ⇒ *Workshop Manual '50561903 Removing and installing rear wheel housing liner (front section)'*
- 7 Install wheel housing liner rear. ⇒ *Workshop Manual '536919 Removing and installing rear wheel housing liner'*
- 8 Enter the campaign in the Warranty and Maintenance booklet.

Replacing connector housing for front antenna cable (scope 2)

Work
Procedure:

Preparatory work

- 1 Remove front left wheel housing liner, (front section). ⇒ *Workshop Manual '50561903 Removing and installing rear wheel housing liner (front section)'*



Information

The number of electric plug connections can vary depending on equipment.

- 2 **Replacing front connector housing (blue/white)**

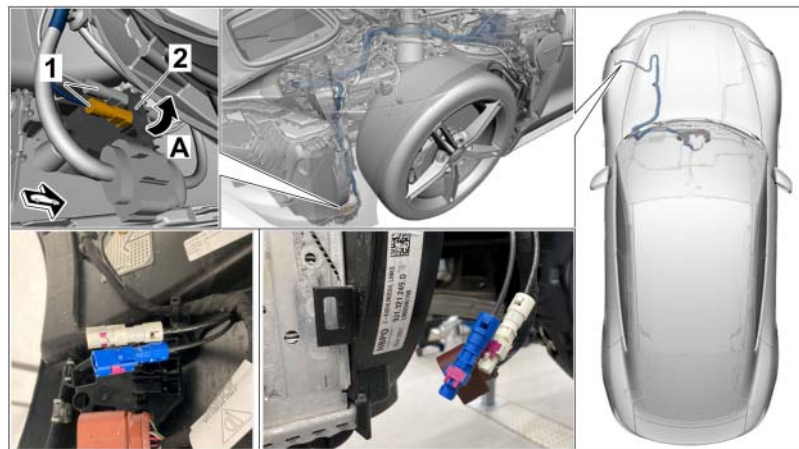

Replacing front connector housing

- 2.1 Unclip plug connections ⇒ *Replacing front connector housing -1-* from ⇒ *Replacing front connector housing -2-* the holder ⇒ *Replacing front connector housing -arrow A-*.
- 2.2 Release electric plug connections and disconnect them.

- 2.3 Check whether the coupler connection \Rightarrow *Checking connector -Arrow-* on both plug connections has visible signs of corrosion.

If no traces of corrosion are visible on the coupler, **continue with Step 2.4.**

If traces of corrosion are visible on the coupler, document this by taking a photograph using a digital camera and repair the antenna cable. For this purpose, **continue with** \Rightarrow *Replace antenna cable and repair plug connection (scope 4-14).*

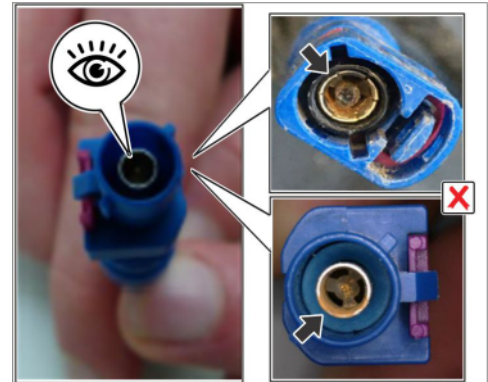

Checking connector

- 2.4 Replace connector housing (on body).
- 2.4.1 Lever off secondary lock on the connector housing \Rightarrow *Disassemble connector housing -1-* using a small screwdriver \Rightarrow *Disassemble connector housing -arrow A-*.
- 2.4.2 Lever off primary lock \Rightarrow *Disassemble connector housing -Arrow B-* and \Rightarrow *Disassemble connector housing -Arrow C-* pull connector housing out of the antenna cable.

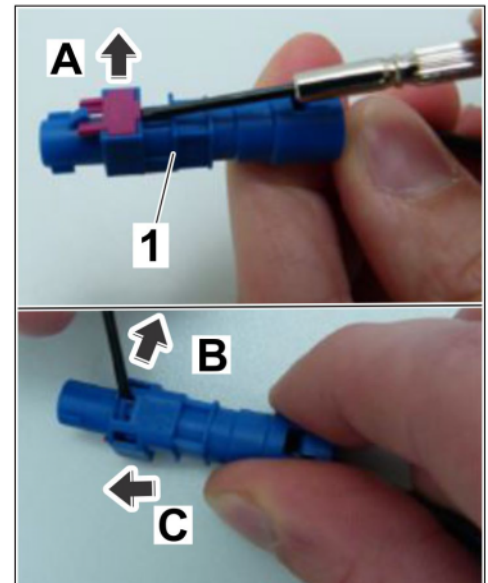

Disassemble connector housing

2.4.3 Dispose of ⇒ *Replacing connector housing -1-* connector housing.

2.4.4 Pull off sleeve ⇒ *Replacing connector housing -2-* on the coupler ⇒ *Replacing connector housing -3-* and dispose of it.

2.4.5 Push in the new sleeve ⇒ *Replacing connector housing -2-* on the coupler ⇒ *Replacing connector housing -3-* up to the anchor block ⇒ *Replacing connector housing -arrow-*.

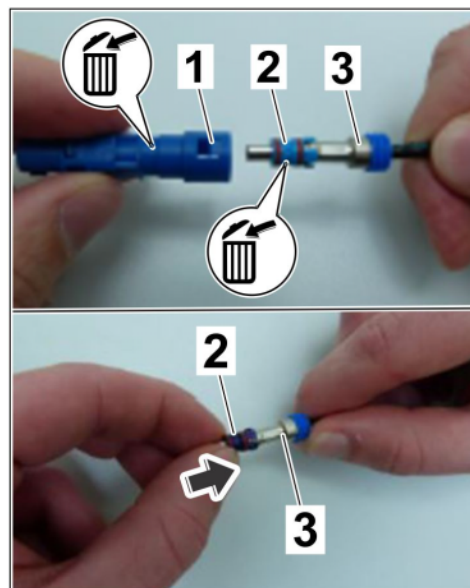

Replacing connector housing

2.4.6 Push in new connector housing (420 series) ⇒ *Assemble connector housing -1-* on the antenna cable ⇒ *Assemble connector housing -1-* until it engages securely ⇒ *Assemble connector housing -Arrows A-*.

2.4.7 Press in secondary lock ⇒ *Assemble connector housing -Arrow B-* and ensure that the antenna cable is locked correctly by pulling.

2.5 Check and replace second plug connection as described in Steps 2.3 to 2.4.

2.6 Connect both plug connections and fasten them in the holder again.

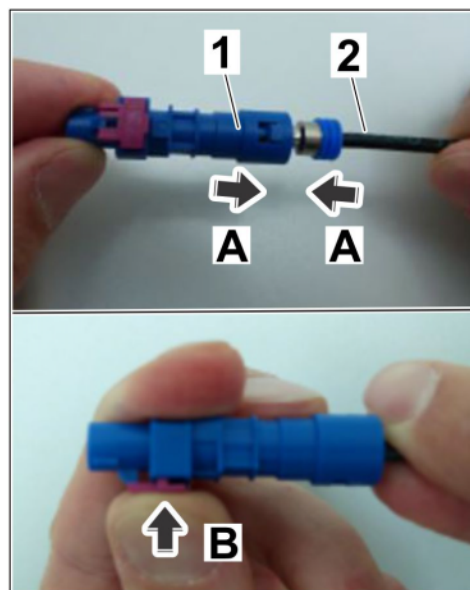

Assemble connector housing

Concluding work

- 3 Install front left wheel housing liner (front section). ⇒ *Workshop Manual '50561903 Removing and installing rear wheel housing liner (front section)'*
- 4 Enter the campaign in the Warranty and Maintenance booklet.

Replacing connector housing for rear antenna cable (scope 3)

Work

Procedure:

Preparatory work

- 1 Remove rear left wheel housing liner. ⇒ *Workshop Manual '536919 Removing and installing rear wheel housing liner'*
- 2 **Replacing rear connector housing (green)**

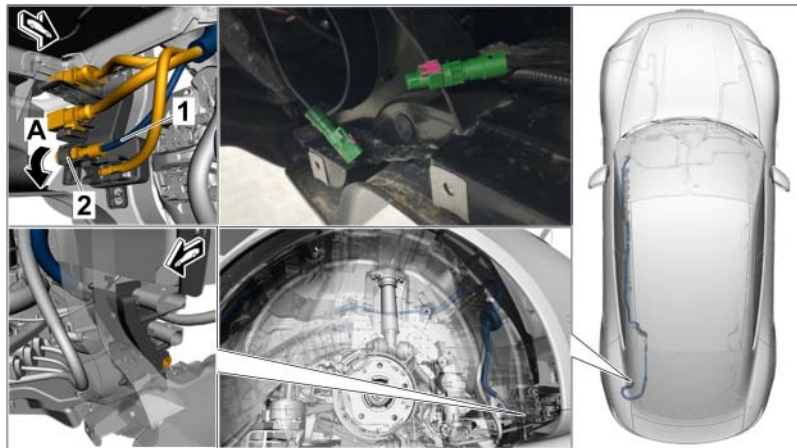

Replacing rear connector housing

- 2.1 Unclip ⇒ *Replacing rear connector housing -1-* plug connection ⇒ *Replacing rear connector housing -2-* from the holder ⇒ *Replacing rear connector housing -arrow A-*.
- 2.2 Release plug connection and disconnect it.
- 2.3 Check whether the coupler connection ⇒ *Checking connector -Arrow-* on both plug connections has visible signs of corrosion.
If no traces of corrosion are visible on the coupler, **continue with Step 2.4**.

If traces of corrosion are visible on the coupler, document this by taking a photograph using a digital camera and repair the antenna cable. For this purpose, **continue with** ⇒ *Replace antenna cable and repair plug connection (scope 4-14)*.

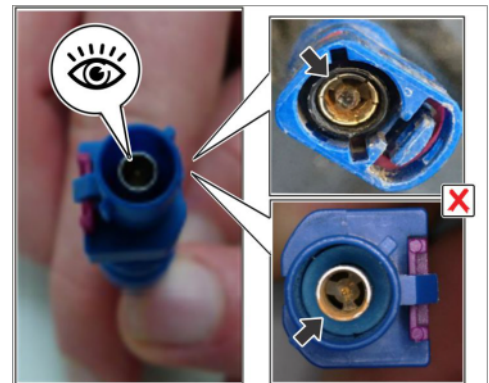

Checking connector

2.4 Replace connector housing (rear bumper).

2.4.1 Lever off secondary lock on the connector housing ⇒ *Disassemble connector housing -1-* using a small screwdriver ⇒ *Disassemble connector housing -arrow A-*.

2.4.2 Lever off primary lock ⇒ *Disassemble connector housing -Arrow B-* and ⇒ *Disassemble connector housing -Arrow C-* pull connector housing out of the antenna cable.

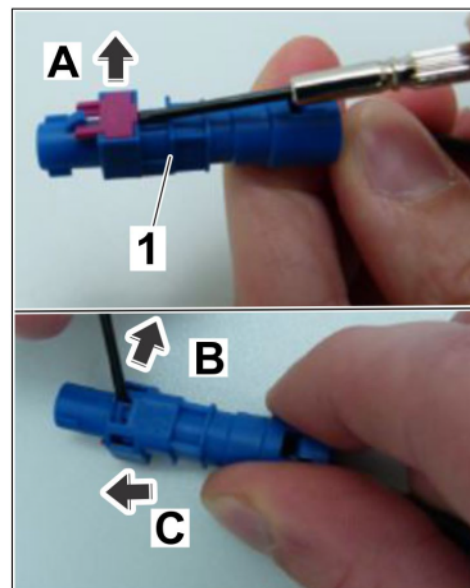

Disassemble connector housing

2.4.3 Dispose of ⇒ *Replacing connector housing -1-* connector housing.

2.4.4 Pull off sleeve ⇒ *Replacing connector housing -2-* on the coupler ⇒ *Replacing connector housing -3-* and dispose of it.

2.4.5 Push in the new sleeve ⇒ *Replacing connector housing -2-* on the coupler ⇒ *Replacing connector housing -3-* up to the anchor block ⇒ *Replacing connector housing -arrow-*.

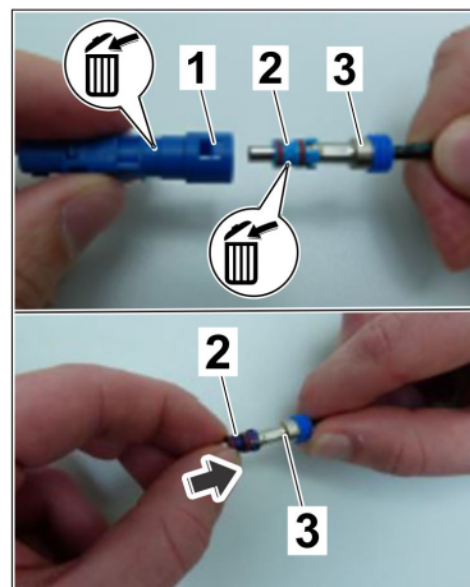

Replacing connector housing

2.4.6 Push in new connector housing (420 series) ⇒ *Assemble connector housing -1-* on the antenna cable ⇒ *Assemble connector housing -1-* until it engages securely ⇒ *Assemble connector housing -Arrows A-*.

2.4.7 Press in secondary lock ⇒ *Assemble connector housing -Arrow B-* and ensure that the antenna cable is locked correctly by pulling.

2.5 Connect both plug connections and fasten them in the holder again.

Concluding work

3 Install wheel housing liner rear. ⇒ *Workshop Manual '536919 Removing and installing rear wheel housing liner'*

4 Enter the campaign in the Warranty and Maintenance booklet.

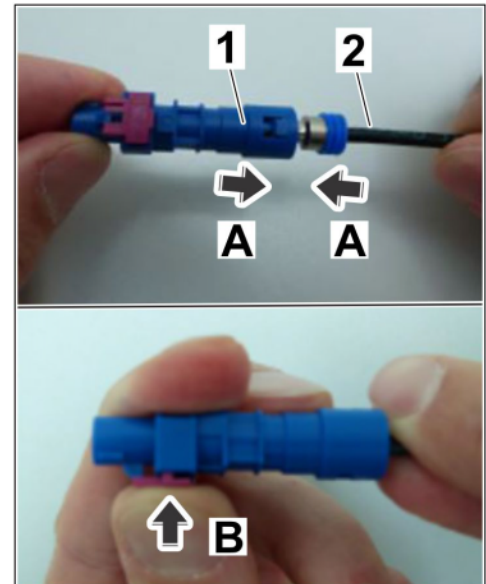

Assemble connector housing

Replace antenna cable and repair plug connection (scope 4-14)

Work Procedure: 1 Preparatory work for replacing the antenna cable.

1.1 Depending on the affected connector/antenna cable, remove the add-on parts:
 Remove front bumper. ⇒ *Workshop Manual '631519 Removing and installing front bumper'*
 or
 Remove rear bumper. ⇒ *Workshop Manual '635519 Removing and installing rear bumper'*



Information

The number of electric plug connections can vary depending on equipment.

2 Replace front antenna cable.

2.1 Connect LTE antenna cable.

- 2.1.1 Release connector ⇒ *Connector for LTE antenna -1-* on LTE antenna and pull it off.
- 2.1.2 Secure both connections of the connector on the wire harness with a tie-wrap and fabric tape.

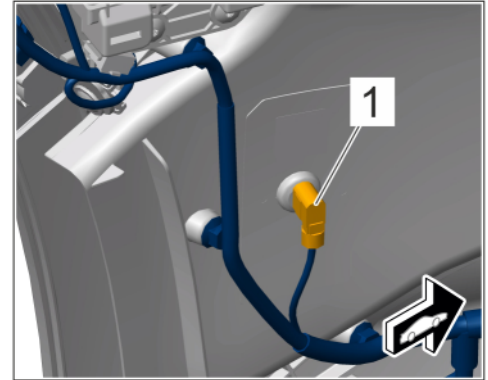

Connector for LTE antenna

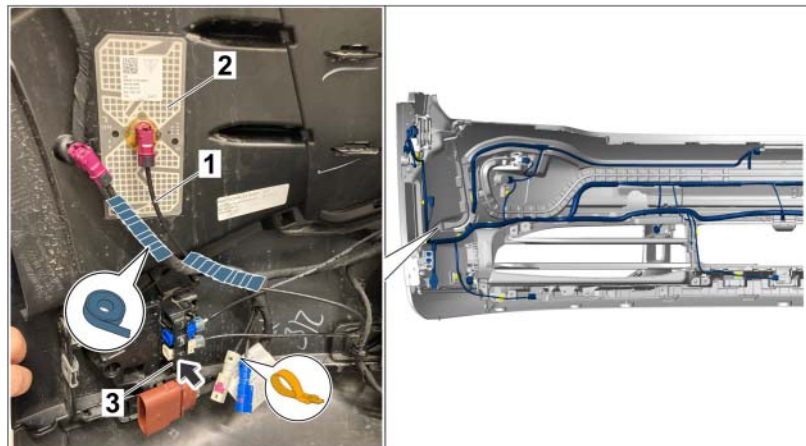

Connect LTE antenna cable

- 2.1.3 Route new LTE antenna cable ⇒ *Connect LTE antenna cable -1-* along the original antenna cable without tension or kinks.
- 2.1.4 Plug in connector on the LTE antenna ⇒ *Connect LTE antenna cable -2-*, until it locks securely.
- 2.1.5 Fasten the connector in the holder ⇒ *Connect LTE antenna cable -3-* again ⇒ *Connect LTE antenna cable -arrow-*.
- 2.1.6 Secure LTE antenna cable with a tie-wrap and fabric tape.
- 2.2 Connect antenna cable for front camera.

- 2.2.1 Release ⇒ *Front camera connector -1-* connector on front camera and pull it off.
- 2.2.2 Secure both connections of the connector on the wire harness with a tie-wrap and fabric tape.

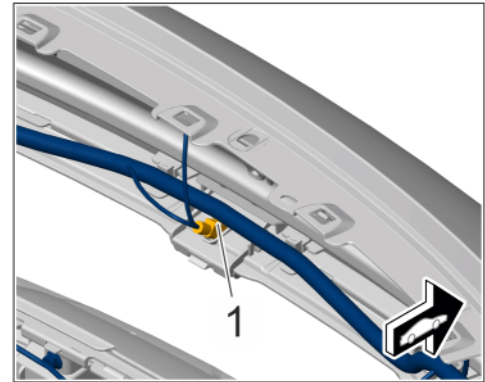

Front camera connector

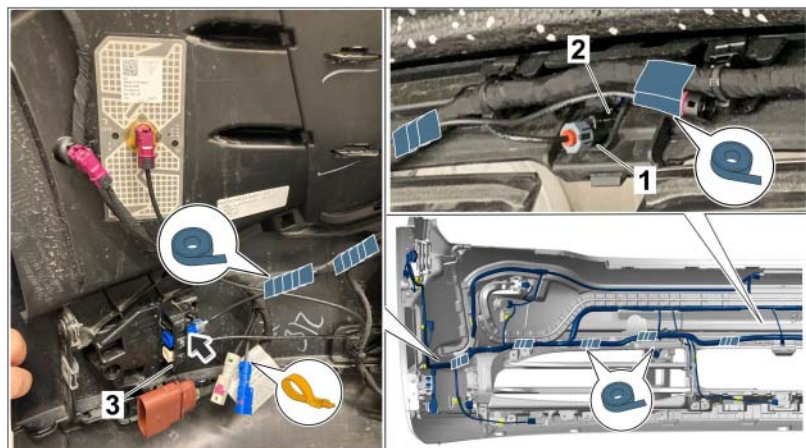

Connecting antenna cable for front camera

- 2.2.3 Route new antenna cable for front camera ⇒ *Connecting antenna cable for front camera -1-* along the original antenna cable without tension or kinks.
- 2.2.4 Plug in connector on the front camera ⇒ *Connecting antenna cable for front camera -2-*, until it locks securely.
- 2.2.5 Fasten the connector in the holder ⇒ *Connecting antenna cable for front camera -3-* again ⇒ *Connecting antenna cable for front camera -arrow-*.
- 2.2.6 Secure antenna cable for front camera with a tie-wrap and fabric insulating tape.
- 2.3 Connect antenna cable for reversing camera.



Connecting antenna cable for reversing camera

- 2.3.1 Release the plug connection ⇒ *Connecting antenna cable for reversing camera -1-* on the short wire harness for the reversing camera ⇒ *Connecting antenna cable for reversing camera -2-* and pull it off.
 - 2.3.2 Secure both connections of the connector on the wire harness with a tie-wrap and fabric tape.
 - 2.3.3 Route new antenna cable for reversing camera along the original antenna cable without tension or kinks.
 - 2.3.4 Plug in connector on the short wire harness for the reversing camera, until it locks securely.
 - 2.3.5 Secure antenna cable with a tie-wrap and fabric insulating tape.
- 3 Repair corroded plug connection for antenna cable (on body).

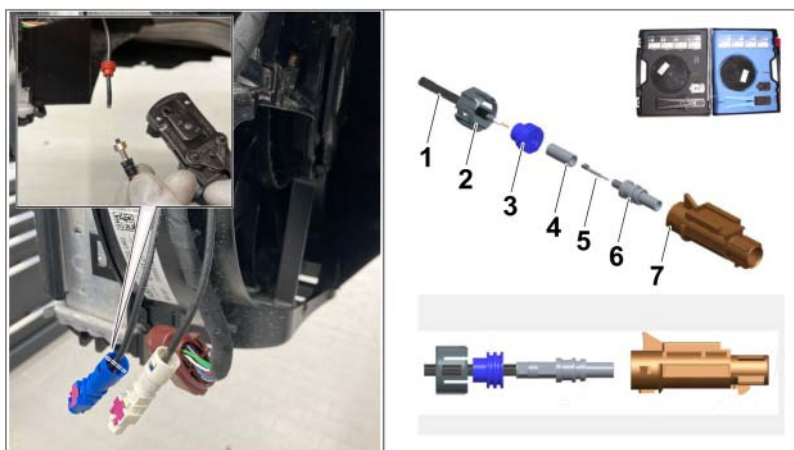

Repairing plug connection

- 1 – Antenna cable
- 2 – Plastic cap

- 3 – Cable seal
- 4 – Crimping sleeve
- 5 – Inner conductor
- 6 – Connector/coupler
- 7 – Connector housing

3.1 Disconnect plug connection as close as possible to the coupler ⇒ *Repairing plug connection -Magnifier-*.

3.2 Replace plug connection according to repair instructions in the **Repair kit for antenna lines (VAS6720)**. ⇒ *Workshop Manual '912841 Repairing antenna cable'*

After stripping, make sure that no corrosion (copper rust) is visible in the antenna cable. Shorten the cable as required until there is no corrosion any more.

4 Rework for replacing the antenna cable.

4.1 Depending on the affected connector/antenna cable, install the add-on parts:

Install front bumper ⇒ *Workshop Manual '631519 Removing and installing front bumper'*
or

Install rear apron, see ⇒ *Workshop Manual '635519 Removing and installing rear bumper'*

5 Enter the campaign in the Warranty and Maintenance booklet.

Warranty processing

Scope 1:

Labor time:

Replacing connector housing for LTE antenna cable, front and reversing camera

Labor time: **90 TU**

Includes: Remove and install front left wheel housing liner (front section)
Remove and install front left wheel housing liner

Parts required:

WNK70000001*	Connector housing set for LTE, front camera and reversing camera	1 piece (for warranty invoicing only)
--------------	--	--

Additional costs:

WNK70000008**	Shipping costs	1 piece (for warranty invoicing only)
---------------	----------------	--

* For warranty processing, the **Part No. WNK70000001** with the designation "WNK7 Repair kit for plug connections" can be invoiced as an **additional part** in the warranty claim. Amount \$31.88.

** For a collective order, the shipping costs may only be invoiced **once for the first vehicle** during warranty processing by specifying **Part No. WNK70000008** with the designation "Shipping costs" as an **additional part** and using the amount as per invoice. **Please document a copy of the invoice for this in the warranty claim.** For all other vehicles, on which parts from this collective order will be used, only the repair kit, expendable items and Labor time are to be invoiced in the warranty claim.

⇒ **Damage code WNK7 066 000 2**

Scope 2:

Labor time:

Replacing connector housing for LTE antenna cable and front camera Labor time: **38 TU**
 Includes: Remove and install front left wheel housing liner
 (front section)

Parts required:

WNK70000002*	Connector housing set for LTE and front camera	1 piece (for warranty invoicing only)
--------------	---	--

Additional costs:

WNK70000008**	Shipping costs	1 piece (for warranty invoicing only)
---------------	----------------	--

* For warranty processing, the **Part No. WNK70000002** with the designation "WNK7 Repair kit for plug connections" can be invoiced as an **additional part** in the warranty claim. Amount \$31.25.

*** For a collective order, the shipping costs may only be invoiced **once for the first vehicle** during warranty processing by specifying **Part No. WNK70000008** with the designation "Shipping costs" as an **additional part** and using the amount as per invoice. **Please document a copy of the invoice for this in the warranty claim.** For all other vehicles, on which parts from this collective order will be used, only the repair kit, expendable items and Labor time are to be invoiced in the warranty claim.

⇒ **Damage code WNK7 066 000 2**

Scope 3:

Labor time:

Replacing connector housing for antenna cable for reversing camera Labor time: **62 TU**
 Includes: Remove and install rear left wheel housing liner

Parts required:

WNK70000003*	Connector housing set for reversing camera	1 piece (for warranty invoicing only)
--------------	---	--

Additional costs:

WNK70000008**	Shipping costs	1 piece (for warranty invoicing only)
---------------	----------------	--

* For warranty processing, the **Part No. WNK70000001** with the designation "WNK7 Repair kit for plug connections" can be invoiced as an **additional part** in the warranty claim. Amount \$30.63.

** For a collective order, the shipping costs may only be invoiced **once for the first vehicle** during warranty processing by specifying **Part No. WNK70000008** with the designation "Shipping costs" as an **additional part** and using the amount as per invoice. **Please document a copy of the invoice for this in the warranty claim.** For all other vehicles, on which parts from this collective order will be used, only the repair kit, expendable items and Labor time are to be invoiced in the warranty claim.

⇒ **Damage code WNK7 066 000 2**

Scope 4:

Labor time:

Replacing antenna cable for front camera and connector housing for LTE antenna	Labor time: 312 TU
--	---------------------------

Includes: Removing and installing front bumper
 Repairing plug connection for front camera

Parts required:

WNK70000002*	Connector housing set for LTE and front camera	1 piece (for warranty invoicing only)
WNK70000004*	Repair kit for antenna cable front camera	1 piece (for warranty invoicing only)

Required materials:

WNK70000007**	Expendable items	1 piece (for warranty invoicing only)
---------------	------------------	--

Additional costs:

WNK70000008***	Shipping costs	1 piece (for warranty invoicing only)
----------------	----------------	--

* For warranty processing, the **Part No. WNK70000002** with the designation "WNK7 Repair kit for plug connections" can be invoiced as an **additional part** in the warranty claim. Amount \$31.25.

* For warranty processing, the **Part No. WNK70000004** with the designation "WNK7 Repair kit for plug connections" can be invoiced as an **additional part** in the warranty claim. Amount \$58.13.

** For warranty processing, the Part No. **WNK70000007** with the designation "Consumable material" can be invoiced as an **additional part** in the warranty claim. Maximum amount \$2.50.

*** For a collective order, the shipping costs may only be invoiced **once for the first vehicle** during warranty processing by specifying **Part No. WNK70000008** with the designation "Shipping costs" as an **additional part** and using the amount as per invoice. **Please document a copy of the invoice for this in the warranty claim.** For all other vehicles, on which parts from this collective order will be used, only the repair kit, expendable items and Labor time are to be invoiced in the warranty claim.

⇒ **Damage code WNK7 066 000 2**

Scope 5:

Labor time:

Replacing antenna cable for LTE antenna and connector housing for front camera Labor time: **305 TU**

Includes: Removing and installing front bumper
 Repairing plug connection for LTE antenna

Parts required:

WNK70000002*	Connector housing set for LTE and front camera	1 piece (for warranty invoicing only)
WNK70000005*	LTE antenna cable repair kit	1 piece (for warranty invoicing only)

Required materials:

WNK70000007**	Expendable items	1 piece (for warranty invoicing only)
---------------	------------------	--

Additional costs:

WNK70000008***	Shipping costs	1 piece (for warranty invoicing only)
----------------	----------------	--

* For warranty processing, the **Part No. WNK70000002** with the designation "WNK7 Repair kit for plug connections" can be invoiced as an **additional part** in the warranty claim. Amount \$31.25.

* For warranty processing, the **Part No. WNK70000005** with the designation "WNK7 Repair kit for plug connections" can be invoiced as an **additional part** in the warranty claim. Amount \$58.13.

** For warranty processing, the Part No. **WNK70000007** with the designation "Consumable material" can be invoiced as an **additional part** in the warranty claim. Maximum amount \$2.50.

*** For a collective order, the shipping costs may only be invoiced **once for the first vehicle** during warranty processing by specifying **Part No. WNK70000008** with the designation "Shipping costs" as an **additional part** and using the amount as per invoice. **Please document a copy of the invoice for this in the warranty claim.** For all other vehicles, on which parts from this collective order will be used, only the repair kit, expendable items and Labor time are to be invoiced in the warranty claim.

⇒ **Damage code WNK7 066 000 2**

Scope 6:

Labor time:Replacing connector housing for reversing camera, LTE antenna cable,
front cameraLabor time: **333 TU**Includes: Removing and installing front bumper
Repairing plug connections for LTE antenna and front
camera**Parts required:**

WNK70000003*	Connector housing set for reversing camera	1 piece (for warranty invoicing only)
WNK70000004*	Repair kit for antenna cable front camera	1 piece (for warranty invoicing only)
WNK70000005*	LTE antenna cable repair kit	1 piece (for warranty invoicing only)

Required materials:

WNK70000007**	Expendable items	1 piece (for warranty invoicing only)
---------------	------------------	--

Additional costs:

WNK70000008***	Shipping costs	1 piece (for warranty invoicing only)
----------------	----------------	--

* For warranty processing, the **Part No. WNK70000003** with the designation "WNK7 Repair kit for plug connections" can be invoiced as an **additional part** in the warranty claim. Amount \$30.63.

* For warranty processing, the **Part No. WNK70000004** with the designation "WNK7 Repair kit for plug connections" can be invoiced as an **additional part** in the warranty claim. Amount \$58.13.

* For warranty processing, the **Part No. WNK70000005** with the designation "WNK7 Repair kit for plug connections" can be invoiced as an **additional part** in the warranty claim. Amount \$58.13.

** For warranty processing, the Part No. **WNK70000007** with the designation "Consumable material" can be invoiced as an **additional part** in the warranty claim. Maximum amount \$2.50.

*** For a collective order, the shipping costs may only be invoiced **once for the first vehicle** during warranty processing by specifying **Part No. WNK70000008** with the designation "Shipping costs" as an **additional part** and using the amount as per invoice. **Please document a copy of the invoice for this in the warranty claim.** For all other vehicles, on which parts from this collective order will be used, only the repair kit, expendable items and Labor time are to be invoiced in the warranty claim.

⇒ **Damage code WNK7 066 000 2**

Scope 7:

Labor time:

Replacing connector housing for LTE antenna, front camera and antenna cable for reversing camera Labor time: **223 TU**

- Includes:
- Remove and install rear left wheel housing liner (front section)
 - Removing and installing rear bumper
 - Repairing plug connection for reversing camera

Parts required:

WNK70000002*	Connector housing set for LTE and front camera	1 piece (for warranty invoicing only)
WNK70000006*	Antenna cable repair kit for reversing camera	1 piece (for warranty invoicing only)

Required materials:

WNK70000007**	Expendable items	1 piece (for warranty invoicing only)
---------------	------------------	--

Additional costs:

WNK70000008***	Shipping costs	1 piece (for warranty invoicing only)
----------------	----------------	--

* For warranty processing, the **Part No. WNK70000002** with the designation "WNK7 Repair kit for plug connections" can be invoiced as an **additional part** in the warranty claim. Amount \$31.25.

* For warranty processing, the **Part No. WNK70000006** with the designation "WNK7 Repair kit for plug connections" can be invoiced as an **additional part** in the warranty claim. Amount \$58.13.

** For warranty processing, the Part No. **WNK70000007** with the designation "Consumable material" can be invoiced as an **additional part** in the warranty claim. Maximum amount \$2.50.

*** For a collective order, the shipping costs may only be invoiced **once for the first vehicle** during warranty processing by specifying **Part No. WNK70000008** with the designation "Shipping costs" as an **additional part** and using the amount as per invoice. **Please document a copy of the invoice for this in the warranty claim.** For all other vehicles, on which parts from this collective order will be used, only the repair kit, expendable items and Labor time are to be invoiced in the warranty claim.

⇒ **Damage code WNK7 066 000 2**

Scope 8:

Labor time:

Replacing antenna cable for LTE antenna, front and reversing camera

Labor time: **467 TU**

Includes: Removing and installing rear bumper
 Removing and installing front bumper
 Repairing plug connections for LTE antenna, front and reversing camera

Parts required:

WNK70000004*	Repair kit for antenna cable front camera	1 piece (for warranty invoicing only)
WNK70000005*	LTE antenna cable repair kit	1 piece (for warranty invoicing only)
WNK70000006*	Antenna cable repair kit for reversing camera	1 piece (for warranty invoicing only)

Required materials:

WNK70000007**	Expendable items	1 piece (for warranty invoicing only)
---------------	------------------	--

Additional costs:

WNK70000008***	Shipping costs	1 piece (for warranty invoicing only)
----------------	----------------	--

* For warranty processing, the **Part No. WNK70000004** with the designation "WNK7 Repair kit for plug connections" can be invoiced as an **additional part** in the warranty claim. Amount \$58.13.

* For warranty processing, the **Part No. WNK70000005** with the designation "WNK7 Repair kit for plug connections" can be invoiced as an **additional part** in the warranty claim. Amount \$58.13.

* For warranty processing, the **Part No. WNK70000006** with the designation "WNK7 Repair kit for plug connections" can be invoiced as an **additional part** in the warranty claim. Amount \$58.13.

** For warranty processing, the Part No. **WNK70000007** with the designation "Consumable material" can be invoiced as an **additional part** in the warranty claim. Maximum amount \$2.50.

*** For a collective order, the shipping costs may only be invoiced **once for the first vehicle** during warranty processing by specifying **Part No. WNK70000008** with the designation "Shipping costs" as an **additional part** and using the amount as per invoice. **Please document a copy of the invoice for this in the warranty claim.** For all other vehicles, on which parts from this collective order will be used, only the repair kit, expendable items and Labor time are to be invoiced in the warranty claim.

⇒ **Damage code WNK7 066 000 2**

Scope 9:

Labor time:

Replacing antenna cable for front camera and connector housing for LTE antenna Labor time: **268 TU**

Includes: Removing and installing front bumper
Repairing plug connection for front camera

Parts required:

WNK70000002*	Connector housing set for LTE and front camera	1 piece (for warranty invoicing only)
--------------	--	--

WNK70000004*	Repair kit for antenna cable front camera	1 piece (for warranty invoicing only)
--------------	---	--

Required materials:

WNK70000007**	Expendable items	1 piece (for warranty invoicing only)
---------------	------------------	--

Additional costs:

WNK70000008***	Shipping costs	1 piece (for warranty invoicing only)
----------------	----------------	--

* For warranty processing, the **Part No. WNK70000002** with the designation "WNK7 Repair kit for plug connections" can be invoiced as an **additional part** in the warranty claim. Amount \$31.25.

* For warranty processing, the **Part No. WNK70000004** with the designation "WNK7 Repair kit for plug connections" can be invoiced as an **additional part** in the warranty claim. Amount \$58.13.

** For warranty processing, the Part No. **WNK70000007** with the designation "Consumable material" can be invoiced as an **additional part** in the warranty claim. Maximum amount \$2.50.

*** For a collective order, the shipping costs may only be invoiced **once for the first vehicle** during warranty processing by specifying **Part No. WNK70000008** with the designation "Shipping costs" as an **additional part** and using the amount as per invoice. **Please document a copy of the invoice for this in the warranty claim.** For all other vehicles, on which parts from this collective order will be used, only the repair kit, expendable items and Labor time are to be invoiced in the warranty claim.

⇒ **Damage code WNK7 066 000 2**

Scope 10:

Labor time:

Replacing antenna cable for LTE antenna and front camera

Labor time: **289 TU**

Includes: Removing and installing front bumper
 Repairing plug connections for LTE antenna and front camera

Parts required:

WNK70000004*	Repair kit for antenna cable front camera	1 piece (for warranty invoicing only)
WNK70000005*	LTE antenna cable repair kit	1 piece (for warranty invoicing only)

Required materials:

WNK70000007**	Expendable items	1 piece (for warranty invoicing only)
---------------	------------------	--

Additional costs:

WNK70000008***	Shipping costs	1 piece (for warranty invoicing only)
----------------	----------------	--

* For warranty processing, the **Part No. WNK70000004** with the designation "WNK7 Repair kit for plug connections" can be invoiced as an **additional part** in the warranty claim. Amount \$58.13.

* For warranty processing, the **Part No. WNK70000005** with the designation "WNK7 Repair kit for plug connections" can be invoiced as an **additional part** in the warranty claim. Amount \$58.13.

** For warranty processing, the Part No. **WNK70000007** with the designation "Consumable material" can be invoiced as an **additional part** in the warranty claim. Maximum amount \$2.50.

*** For a collective order, the shipping costs may only be invoiced **once for the first vehicle** during warranty processing by specifying **Part No. WNK70000008** with the designation "Shipping costs" as an **additional part** and using the amount as per invoice. **Please document a copy of the invoice for this in the warranty claim.** For all other vehicles, on which parts from this collective order will be used, only the repair kit, expendable items and Labor time are to be invoiced in the warranty claim.

⇒ Damage code **WNK7 066 000 2**

Scope 11:

Labor time:

Replacing antenna cable for LTE antenna and connector housing for front camera Labor time: **261 TU**
 Includes: Removing and installing front bumper
 Repairing plug connections for LTE antenna

Parts required:

WNK70000002*	Connector housing set for LTE and front camera	1 piece (for warranty invoicing only)
WNK70000005*	LTE antenna cable repair kit	1 piece (for warranty invoicing only)

Required materials:

WNK70000007**	Expendable items	1 piece (for warranty invoicing only)
---------------	------------------	--

Additional costs:

WNK70000008***	Shipping costs	1 piece (for warranty invoicing only)
----------------	----------------	--

* For warranty processing, the **Part No. WNK70000002** with the designation "WNK7 Repair kit for plug connections" can be invoiced as an **additional part** in the warranty claim. Amount \$31.88.

* For warranty processing, the **Part No. WNK70000005** with the designation "WNK7 Repair kit for plug connections" can be invoiced as an **additional part** in the warranty claim. Amount \$58.13.

** For warranty processing, the Part No. **WNK70000007** with the designation "Consumable material" can be invoiced as an **additional part** in the warranty claim. Maximum amount \$2.50.

*** For a collective order, the shipping costs may only be invoiced **once for the first vehicle** during warranty processing by specifying **Part No. WNK70000008** with the designation "Shipping costs" as an **additional part** and using the amount as per invoice. **Please document a copy of the invoice for this in the warranty claim.** For all other vehicles, on which parts from this collective order will be used, only the repair kit, expendable items and Labor time are to be invoiced in the warranty claim.

⇒ **Damage code WNK7 066 000 2**

Scope 12:

Labor time:

Replacing antenna cable for reversing camera Labor time: **195 TU**
 Includes: Removing and installing rear bumper
 Repairing plug connection for reversing camera

Parts required:

WNK70000006*	Antenna cable repair kit for reversing camera	1 piece (for warranty invoicing only)
--------------	---	--

Required materials:

WNK70000007**	Expendable items	1 piece (for warranty invoicing only)
---------------	------------------	--

Additional costs:

WNK70000008***	Shipping costs	1 piece (for warranty invoicing only)
----------------	----------------	--

* For warranty processing, the **Part No. WNK70000006** with the designation "WNK7 Repair kit for plug connections" can be invoiced as an **additional part** in the warranty claim. Amount \$58.13.

** For warranty processing, the Part No. **WNK70000007** with the designation "Consumable material" can be invoiced as an **additional part** in the warranty claim. Maximum amount \$2.50.

*** For a collective order, the shipping costs may only be invoiced **once for the first vehicle** during warranty processing by specifying **Part No. WNK70000008** with the designation "Shipping costs" as an **additional part** and using the amount as per invoice. **Please document a copy of the invoice for this in the warranty claim.** For all other vehicles, on which parts from this collective order will be used, only the repair kit, expendable items and Labor time are to be invoiced in the warranty claim.

⇒ **Damage code WNK7 066 000 2**

Scope 13:

Labor time:

Replacing connector housing for LTE antenna, replace antenna cable for front and reversing camera Labor time: **431 TU**

Includes: Removing and installing rear bumper
Removing and installing front bumper
Repairing plug connections for front and reversing camera

Parts required:

WNK70000002*	Connector housing set for LTE and front camera	1 piece (for warranty invoicing only)
--------------	--	--

WNK70000004*	Repair kit for antenna cable front camera	1 piece (for warranty invoicing only)
--------------	---	--

WNK70000006*	Antenna cable repair kit for reversing camera	1 piece (for warranty invoicing only)
--------------	---	--

Required materials:

WNK70000007**	Expendable items	1 piece (for warranty invoicing only)
Additional costs:		
WNK70000008***	Shipping costs	1 piece (for warranty invoicing only)
<p>* For warranty processing, the Part No. WNK70000002 with the designation "WNK7 Repair kit for plug connections" can be invoiced as an additional part in the warranty claim. Amount \$31.25.</p> <p>* For warranty processing, the Part No. WNK70000004 with the designation "WNK7 Repair kit for plug connections" can be invoiced as an additional part in the warranty claim. Amount \$58.13.</p> <p>* For warranty processing, the Part No. WNK70000006 with the designation "WNK7 Repair kit for plug connections" can be invoiced as an additional part in the warranty claim. Amount \$58.13.</p> <p>** For warranty processing, the Part No. WNK70000007 with the designation "Consumable material" can be invoiced as an additional part in the warranty claim. Maximum amount \$2.50.</p> <p>*** For a collective order, the shipping costs may only be invoiced once for the first vehicle during warranty processing by specifying Part No. WNK70000008 with the designation "Shipping costs" as an additional part and using the amount as per invoice. Please document a copy of the invoice for this in the warranty claim. For all other vehicles, on which parts from this collective order will be used, only the repair kit, expendable items and Labor time are to be invoiced in the warranty claim.</p> <p>⇒ Damage code WNK7 066 000 2</p>		

Scope 14:

Labor time:		
Replace connector housing for front camera, replace antenna cable for LTE antenna and reversing camera		Labor time: 425 TU
Includes:	<ul style="list-style-type: none"> Removing and installing rear bumper Removing and installing front bumper Repairing plug connections for LTE antenna and reversing camera 	
Parts required:		
WNK70000002*	Connector housing set for LTE and front camera	1 piece (for warranty invoicing only)
WNK70000005*	LTE antenna cable repair kit	1 piece (for warranty invoicing only)
WNK70000006*	Antenna cable repair kit for reversing camera	1 piece (for warranty invoicing only)
Required materials:		

WNK70000007**	Expendable items	1 piece (for warranty invoicing only)
Additional costs:		
WNK70000008***	Shipping costs	1 piece (for warranty invoicing only)

* For warranty processing, the **Part No. WNK70000002** with the designation "WNK7 Repair kit for plug connections" can be invoiced as an **additional part** in the warranty claim. Amount \$31.25.

* For warranty processing, the **Part No. WNK70000005** with the designation "WNK7 Repair kit for plug connections" can be invoiced as an **additional part** in the warranty claim. Amount \$58.13.

* For warranty processing, the **Part No. WNK70000006** with the designation "WNK7 Repair kit for plug connections" can be invoiced as an **additional part** in the warranty claim. Amount \$58.13.

** For warranty processing, the Part No. **WNK70000007** with the designation "Consumable material" can be invoiced as an **additional part** in the warranty claim. Maximum amount \$2.50.

*** For a collective order, the shipping costs may only be invoiced **once for the first vehicle** during warranty processing by specifying **Part No. WNK70000008** with the designation "Shipping costs" as an **additional part** and using the amount as per invoice. **Please document a copy of the invoice for this in the warranty claim.** For all other vehicles, on which parts from this collective order will be used, only the repair kit, expendable items and Labor time are to be invoiced in the warranty claim.

⇒ **Damage code WNK7 066 000 2**

Important Notice: Technical Bulletins issued by Porsche Cars North America, Inc. are intended only for use by professional automotive technicians who have attended Porsche service training courses. They are written to inform those technicians of conditions that may occur on some Porsche vehicles, or to provide information that could assist in the proper servicing of a vehicle. Porsche special tools may be necessary in order to perform certain operations identified in these bulletins. Use of tools and procedures other than those Porsche recommends in these bulletins may be detrimental to the safe operation of your vehicle, and may endanger the people working on it. Properly trained Porsche technicians have the equipment, tools, safety instructions, and know-how to do the job properly and safely. Part numbers listed in these bulletins are for reference only. The work procedures updated electronically in the Porsche PIWIS diagnostic and testing device take precedence and, in the event of a discrepancy, the work procedures in the PIWIS Tester are the ones that must be followed.

© 2022 Porsche Cars North America, Inc.