

Subject: CORRECTIONS TO THE CX-50 TOW HITCH INSTALLATION INSTRUCTIONS	Service Alert No.: SA-021/22
	Last Issued : 09/07/2022

BULLETIN NOTES

This SA supersedes the previously issued SA(s) listed below. The changes are noted in Red.

Previous SAs:	Date(s) Issued:
SA-021/22	04/21/22

APPLICABLE MODEL(S)/VINS

2023 CX-50

DESCRIPTION

The installation instructions included in the box with the tow hitch accessory, part number **VA40-V3-920**, are not correct. Please read this Service Alert before beginning the installation process of the accessory tow hitch.

REPAIR PROCEDURE

PREPARATION OF WIRING HARNESS BEFORE INSTALLATION

The zip tie locations on CX-50 4-pin (**VA40-V7-780**) and 7-pin (**VA41-V7-780**) trailer hitch harnesses are not correct. Before beginning the installation of the trailer hitch harness, follow the steps below to confirm the zip ties are spaced correctly.

- Carefully measure the location of the zip ties. Is the location correct as shown in the images below?
YES: Skip to the ADDITIONAL ZIP TIE MOUNT POINTS section.
NO: Continue to STEP 2.
- Carefully move the existing zip ties into their new locations as shown in the images below.
NOTE: If zip ties are not able to be moved, carefully cut existing zip ties from the harness and replace them with new zip ties. DO NOT CUT OR DAMAGE THE CORRUGATED TUBING OR WIRES CONTAINED WITHIN.

CONSUMER NOTICE: The information and instructions in this bulletin are intended for use by skilled technicians. Mazda technicians utilize the proper tools/ equipment and take training to correctly and safely maintain Mazda vehicles. These instructions should not be performed by "do-it-yourselfers." Customers should not assume this bulletin applies to their vehicle or that their vehicle will develop the described concern. To determine if the information applies, customers should contact their nearest authorized Mazda dealership. Mazda North American Operations reserves the right to alter the specifications and contents of this bulletin without obligation or advance notice. All rights reserved. No part of this bulletin may be reproduced in any form or by any means, electronic or mechanical--including photocopying and recording and the use of any kind of information storage and retrieval system ---without permission in writing.

4-PIN (VA40-V7-780) 2.5L (NON-TURBO) - CORRECT ZIP TIE SPACING

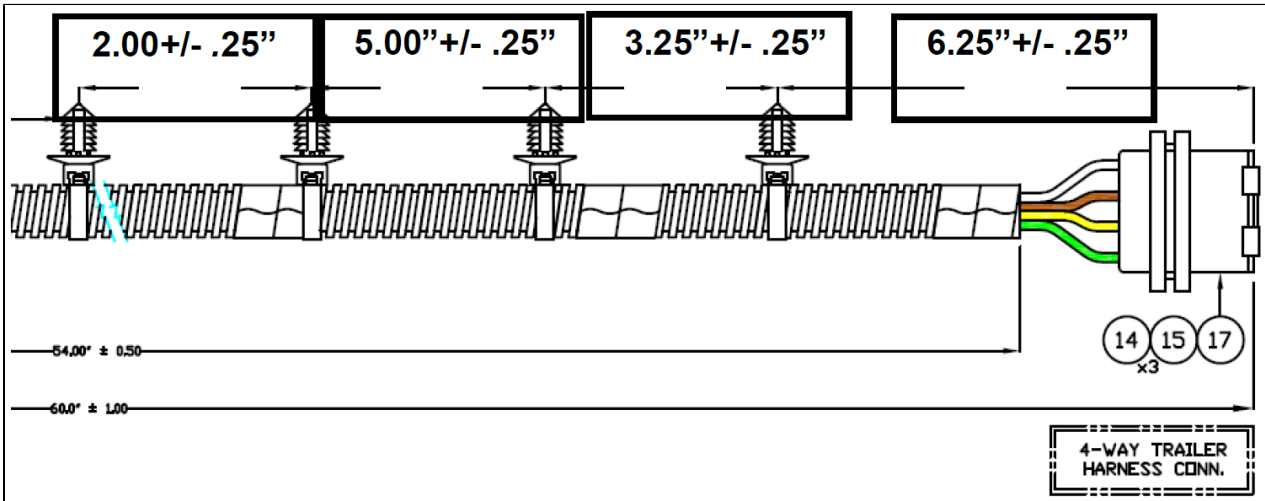

7-PIN (VA41-V7-780) 2.5L TURBO - CORRECT ZIP TIE SPACING

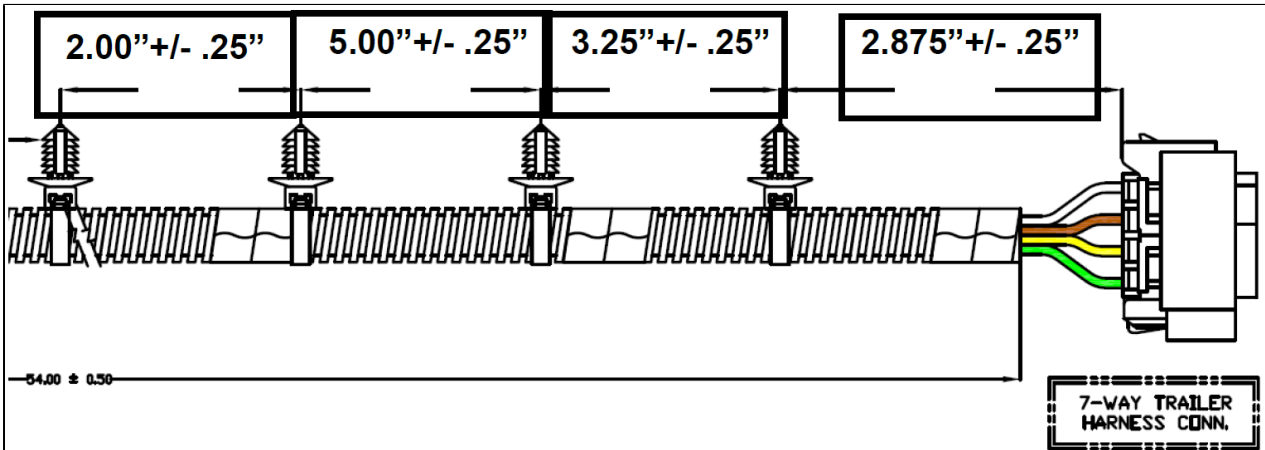

CONSUMER NOTICE: The information and instructions in this bulletin are intended for use by skilled technicians. Mazda technicians utilize the proper tools/ equipment and take training to correctly and safely maintain Mazda vehicles. These instructions should not be performed by "do-it-yourselfers." Customers should not assume this bulletin applies to their vehicle or that their vehicle will develop the described concern. To determine if the information applies, customers should contact their nearest authorized Mazda dealership. Mazda North American Operations reserves the right to alter the specifications and contents of this bulletin without obligation or advance notice. All rights reserved. No part of this bulletin may be reproduced in any form or by any means, electronic or mechanical---including photocopying and recording and the use of any kind of information storage and retrieval system ---without permission in writing.

CHANGE ORDER OF OPERATION WHEN INSTALLING 7-PIN TRAILER CONNECTOR

Due to the restricted space in which to install the connector mounting screws, the *7-pin harness* must be installed onto the trailer hitch before installing the hitch.

1. Place trailer hitch on a stable workplace location.
2. Follow *SECTION 5, STEPS 1 THROUGH 4* of the *original* trailer hitch harness installation instructions to install the connector and harness to the trailer hitch.
NOTE: If you do not have a copy, you can download a copy from the Accessories E-catalog (Installation Instructions).
3. Before installing the hitch, continue to the next section.



CONSUMER NOTICE: The information and instructions in this bulletin are intended for use by skilled technicians. Mazda technicians utilize the proper tools/ equipment and take training to correctly and safely maintain Mazda vehicles. These instructions should not be performed by "do-it-yourselfers." Customers should not assume this bulletin applies to their vehicle or that their vehicle will develop the described concern. To determine if the information applies, customers should contact their nearest authorized Mazda dealership. Mazda North American Operations reserves the right to alter the specifications and contents of this bulletin without obligation or advance notice. All rights reserved. No part of this bulletin may be reproduced in any form or by any means, electronic or mechanical---including photocopying and recording and the use of any kind of information storage and retrieval system ---without permission in writing.

TRIM BUMPER BRACKET TAB BEFORE INSTALLING THE HITCH

Before installing the trailer hitch, you must trim 5 mm from a mounting tab on the vehicle bumper to provide clearance for the harness connector. See the image below to determine which tab and what portion of the tab must be removed.

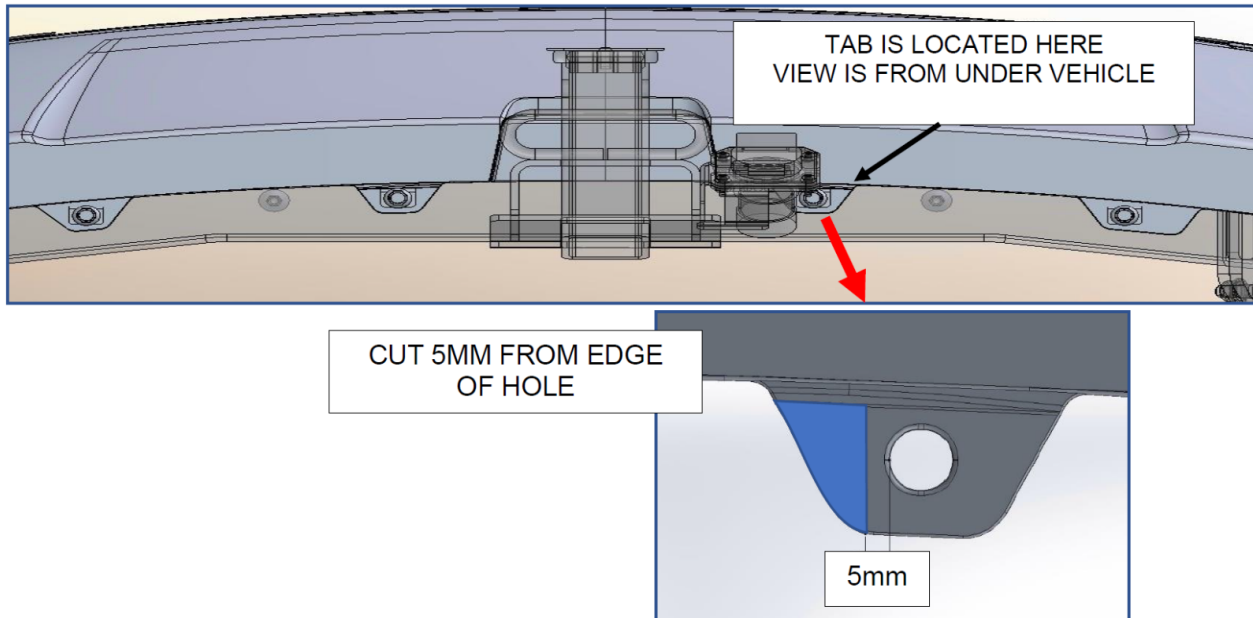

CRITICAL FINAL STEP

Be sure to complete the trailer hitch harness installation instructions in Section 5 and check for a minimum clearance of 50 mm between all portions of the trailer hitch harness and the exhaust system. Failure to do so will result in damage to the harness.

CONSUMER NOTICE: The information and instructions in this bulletin are intended for use by skilled technicians. Mazda technicians utilize the proper tools/ equipment and take training to correctly and safely maintain Mazda vehicles. These instructions should not be performed by "do-it-yourselfers." Customers should not assume this bulletin applies to their vehicle or that their vehicle will develop the described concern. To determine if the information applies, customers should contact their nearest authorized Mazda dealership. Mazda North American Operations reserves the right to alter the specifications and contents of this bulletin without obligation or advance notice. All rights reserved. No part of this bulletin may be reproduced in any form or by any means, electronic or mechanical---including photocopying and recording and the use of any kind of information storage and retrieval system ---without permission in writing.