

September 30, 2022

Version 3

## Safety Recall: 2019-20 TLX SH-AWD Fuel Pump Motor

Supersedes 21-017, dated August 6, 2021, to revise the information highlighted in **yellow**.

### AFFECTED VEHICLES

Year	Model	Trim Level	VIN Range
2019-20	TLX SH-AWD	ALL	Check the iN VIN status for eligibility.

### REVISION SUMMARY

Under REPAIR PROCEDURE, step 27 was revised and an image was added.

### BACKGROUND

Due to swelling of the fuel pump motor impeller, the fuel pump may seize and stop working. If this occurs, the check engine light may be displayed with DTC P0087 (Fuel Rail Pressure Too Low) stored, the engine may not start, or the engine could stall while driving, increasing the risk of a crash.

### CLIENT NOTIFICATION

Owners of affected vehicles will be sent a notification of this campaign.

Do an iN VIN status inquiry to make sure the vehicle is shown as eligible.

Some vehicles affected by this campaign may be in your new or used vehicle inventory.

Failure to repair a vehicle subject to a recall or campaign may subject your dealership to claims or lawsuits from the client or anyone else harmed as a result of such failure. To see if a vehicle in inventory is affected by this safety recall, do a VIN status inquiry before selling it.

### CORRECTIVE ACTION

Replace the fuel pump motor.

NOTE: If the vehicle has any of the symptoms listed in BACKGROUND, you must apply this bulletin before attempting any other repairs. If the symptoms remain after the recall repair is complete, only attempt further repairs (such as replacing the high pressure fuel pump) after authorized troubleshooting.

### PARTS INFORMATION

NOTE: Due to limited supply, this is a controlled part and will require a valid VIN when ordering.

Part Name	Part Number	Quantity
Fuel Pump Motor Kit	06170-TZ7-306	1

**For dealers experiencing a strong fuel smell from storing a fuel pump motor replaced under this service bulletin,** the fuel pump motor may be disposed of immediately in accordance with local regulations. This only applies to the fuel pump motor replaced under this service bulletin. The published retention policy remains in effect for all other parts.

If you have any questions about this exception or other parts retention issues, contact the WPI Administrative Office at **937-642-2737**.

**CLIENT INFORMATION:** The information in this bulletin is intended for use only by skilled technicians who have the proper tools, equipment, and training to correctly and safely maintain your vehicle. These procedures should not be attempted by "do-it-yourselfers," and you should not assume this bulletin applies to your vehicle, or that your vehicle has the condition described. To determine whether this information applies, contact an authorized Acura automobile dealer.

## TOOL INFORMATION

Tool Name	Tool Number	Quantity
Fuel Sender Wrench	070AA-T0AA100	1

## WARRANTY CLAIM INFORMATION

Operation Number	Description	Flat Rate Time	Defect Code	Symptom Code	Template ID	Failed Part Number
3101HK	Replace the fuel pump motor.	0.9 hr	6FE00	BAS00	B21017A	17045-TZ7-A00

Skill Level: Repair Technician

## REPAIR PROCEDURE

### ⚠ WARNING

Fuel pump motor removal exposes fuel, which can ignite, causing a fire or explosion.

This can cause serious injury or death.

Always work in a well-ventilated area, and keep sparks or open flames away.

1. Insert the emergency fuel funnel into the fuel filler neck to relieve the pressure in the fuel tank.

NOTE: Remove the emergency fuel funnel from its case in the trunk tool box.

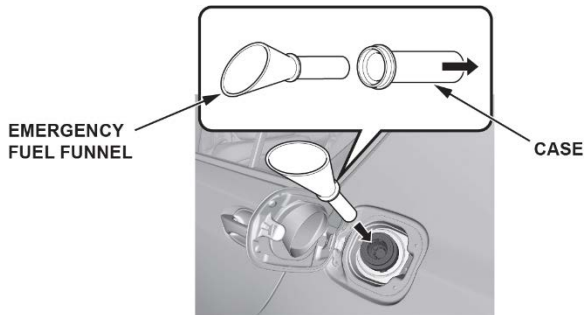

2. Relieve the fuel pressure.

*With an i-HDS*

- Connect an i-HDS to the vehicle.
- Turn the vehicle to ON.
- Select the **PGM-FI** system on the i-HDS.
- Select **FUEL PUMP OFF** from the **Function Test** menu.
- Start the engine and let it idle until it stalls.
- Turn the ignition to OFF.

*Without an i-HDS*

- Remove the PGM-FI main relay 2 from the under-dash fuse/relay box.

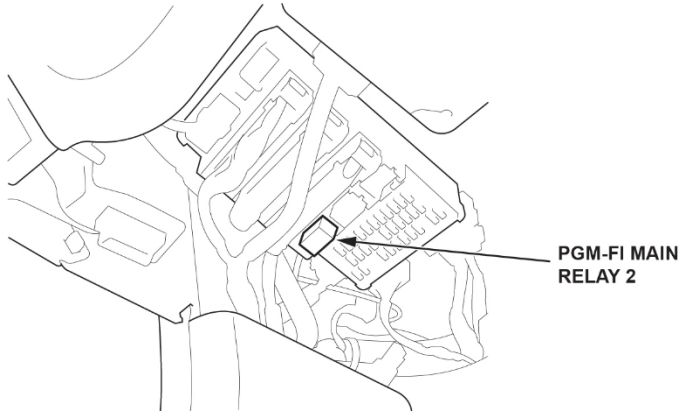

- Start the engine and let it idle until it stalls.
- Turn the ignition to OFF.
- Install the PGM-FI main relay 2.

**NOTE:**

- Do not allow the engine to idle above 1,000 rpm or the PCM will continue to operate the fuel pump.
- A pending or confirmed DTC may be set during this procedure. After the repair is complete, check for DTCs, and clear them as needed.

3. Open the positive battery terminal cover.
4. Disconnect both 12-volt battery terminals.

**NOTICE**

To protect the terminal connector from damage, do not hold it when removing the negative terminal.

**NOTE:**

- Always disconnect the negative terminal first.
- Do not disconnect the 12-volt battery sensor from the cable.

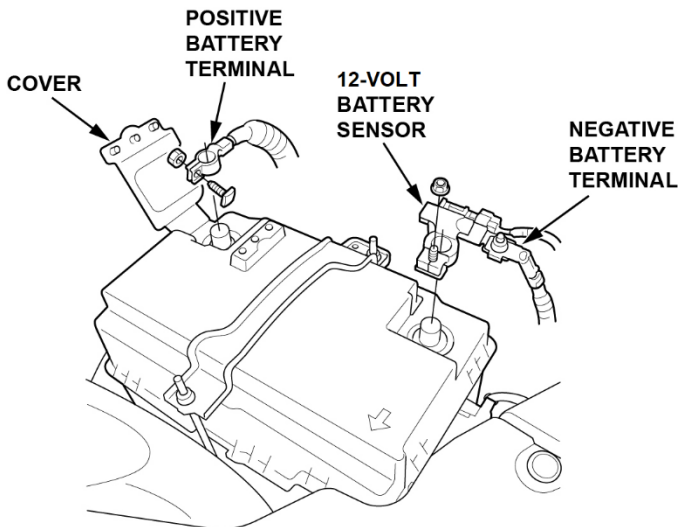

5. Remove the rear seat cushion bolt.

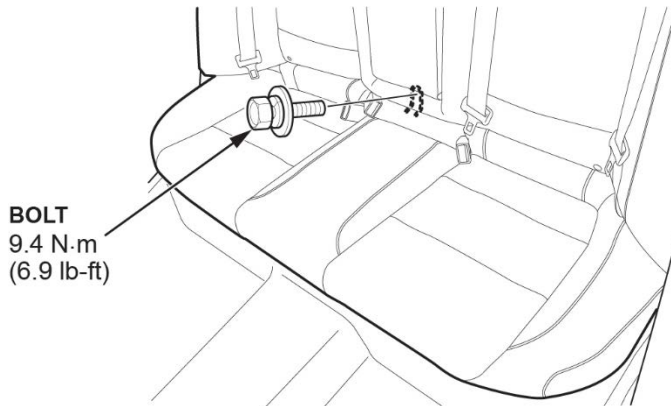

6. While pushing down on the rear seat cushion, pull the seat hook handles to release the hooks.

*With rear seat heaters:* Disconnect the connectors and remove the harness clips.

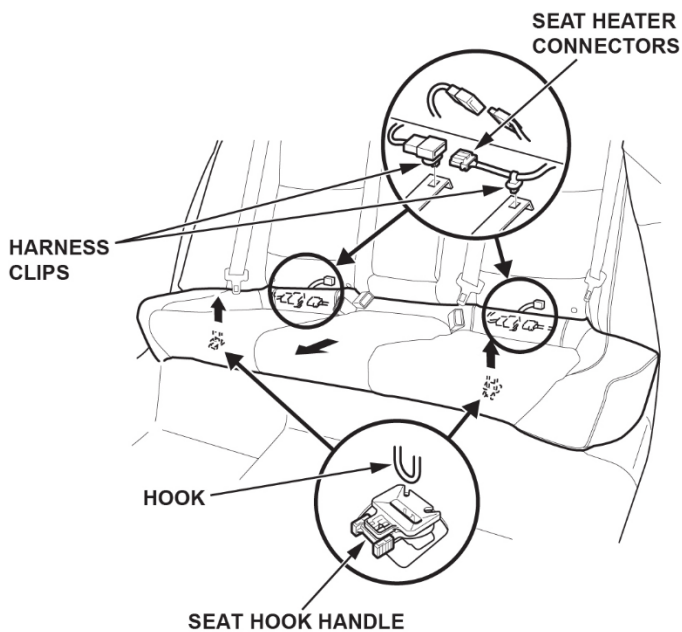

7. Pull back the seat cushion to pull off the seat belt buckles from the slits in the seat cushion.
8. Remove the rear seat cushion.

9. Remove the fuel tank unit access panel and disconnect the fuel pump unit connector.

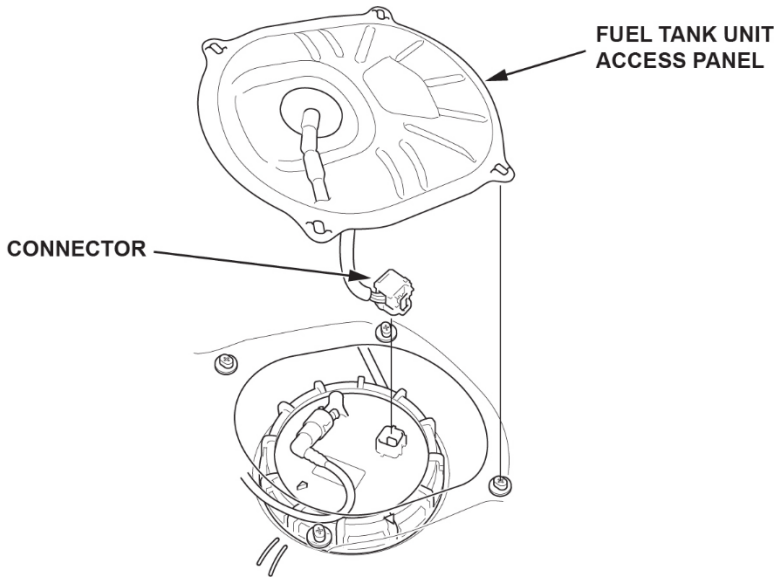

10. Place a rag or shop towel over the quick-connect fitting, and disconnect it.

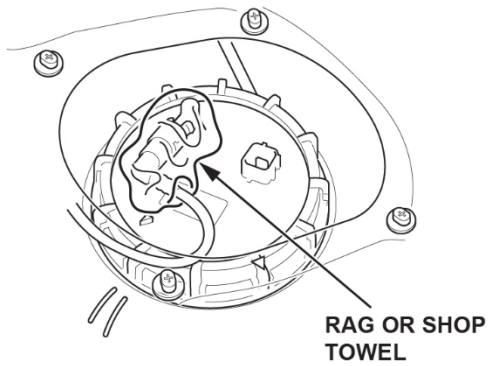

11. Remove the fuel tank unit locknut using the fuel sender wrench (T/N 070AA-T0AA100) as shown.

NOTE:

- Keep the fuel sender wrench from floating.
- After unlocking the fuel tank unit cam lock ring, clean the top of the fuel pump flange and adjacent areas to make sure it's free of dirt, dust, and debris.

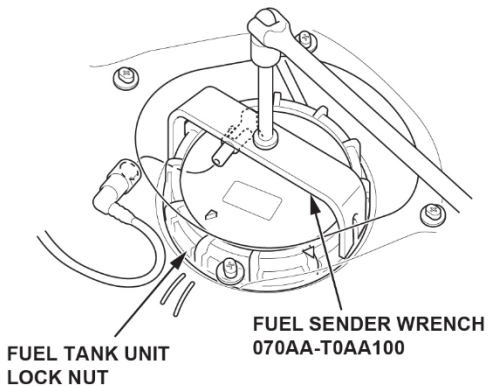

12. Remove the fuel tank unit.

**NOTICE**

Do not to bend or twist the fuel level sensor arm excessively. This may damage the fuel level sensor or cause it to send inaccurate readings.

**NOTE:**

- After removing the fuel pump unit, clean the fuel tank around the fuel pump opening.
- After removing the fuel pump O-ring, clean the fuel tank around the O-ring opening and make sure it's free of dirt, dust, and debris.

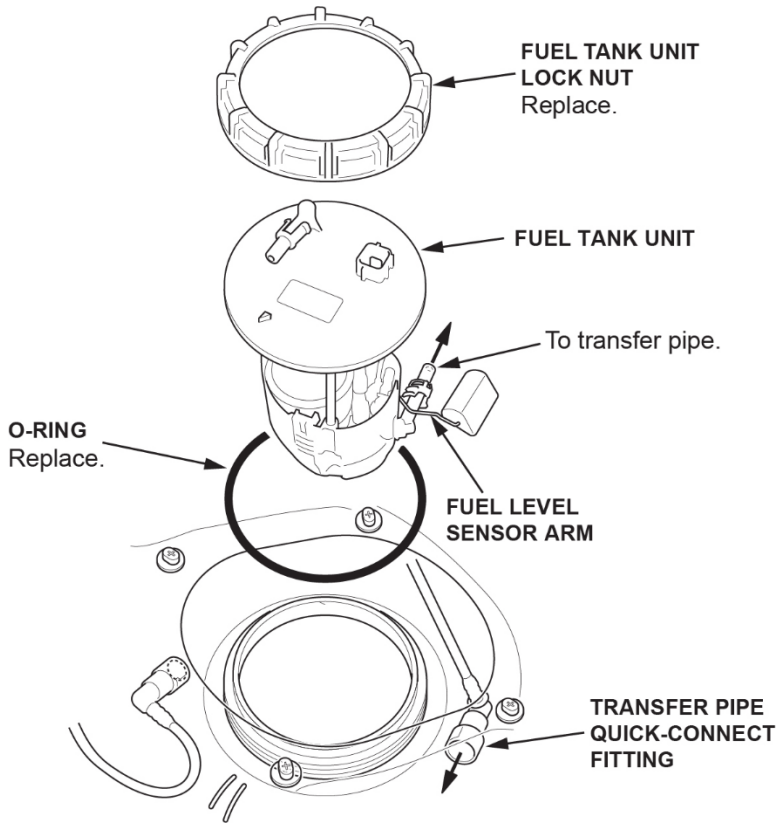

13. Disconnect the transfer pipe quick-connect fitting.

14. Prepare the fuel pump and parts to be replaced.

**NOTE:** Take a photo of the fuel tube and wire harness, and note their routing for assembly. There are various types of routing.

15. Spread the wire harness clamps and remove the wire harness. Make sure not to damage the wire harness.

**NOTICE**

Do not spread the clamps too wide. Spreading them too wide may damage them.

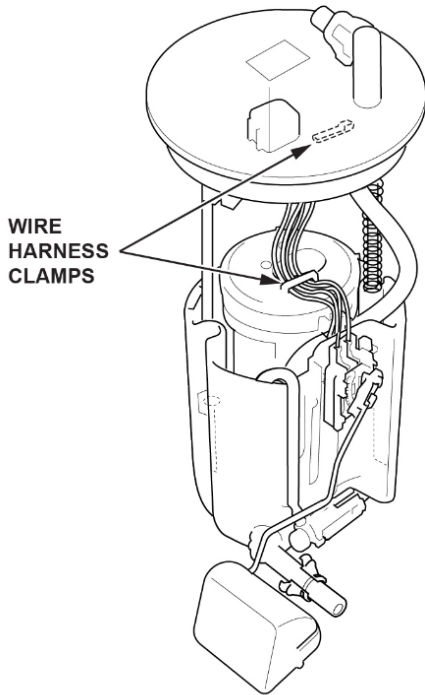

16. Press the tab on the fuel level sensor to release the lock. Then, push up on the fuel level sensor.

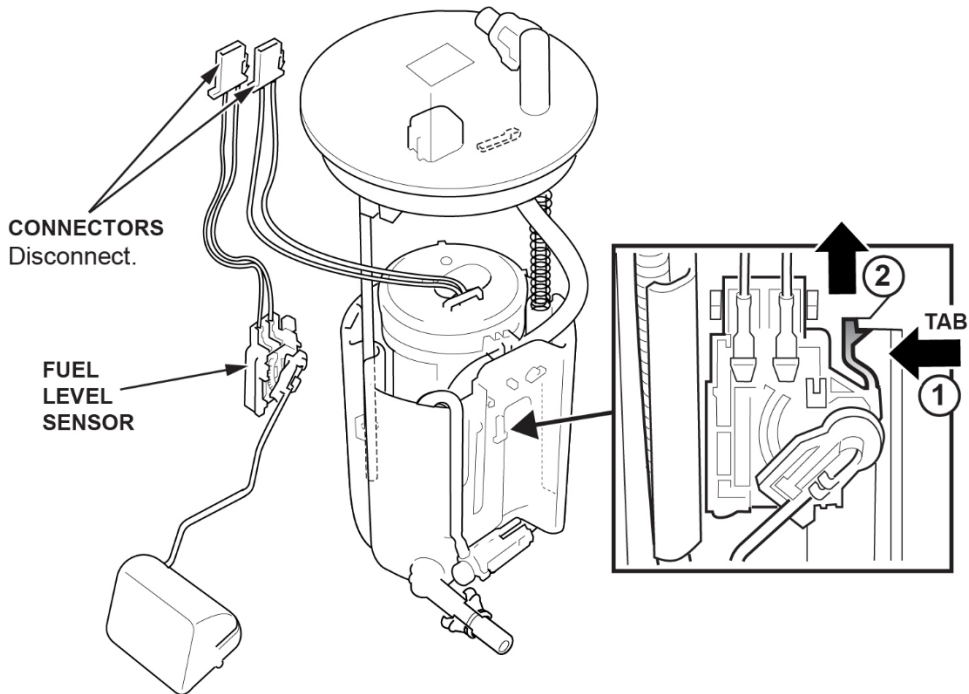

17. Disconnect the fuel level sensor harness and remove the fuel level sensor from the fuel tank unit.

18. Remove the E-rings and discard them.

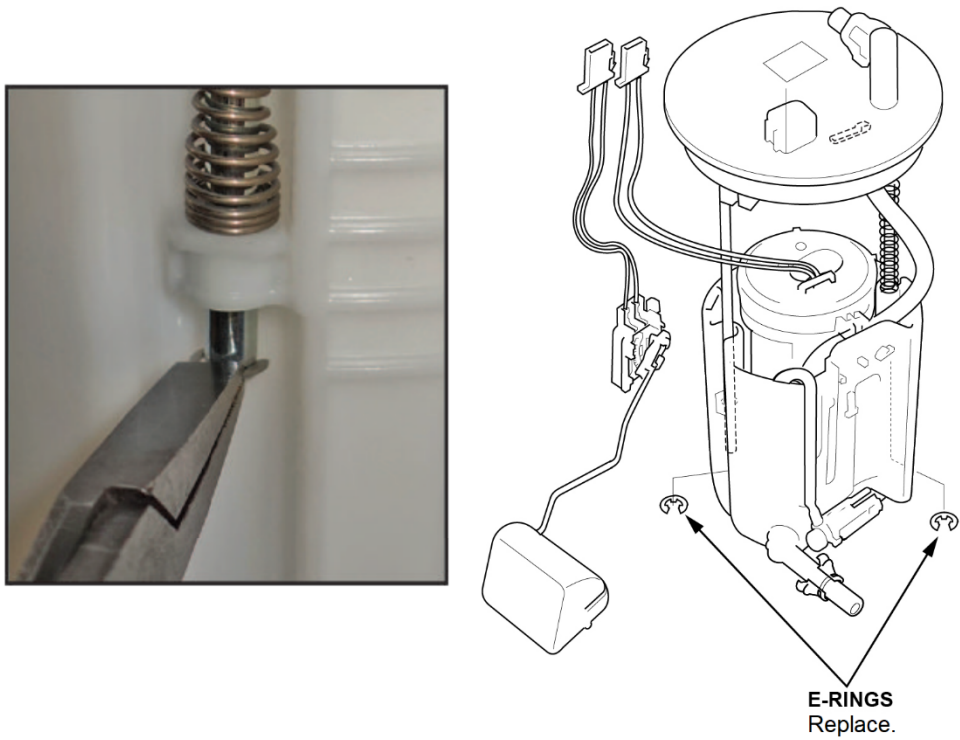

19. Use an O-ring pick to disconnect Joint A inside the reservoir.

NOTE: If the O-ring remains inside the joint, use a flathead screwdriver wrapped in protective tape to remove it. Take care not to damage the O-ring seat section.

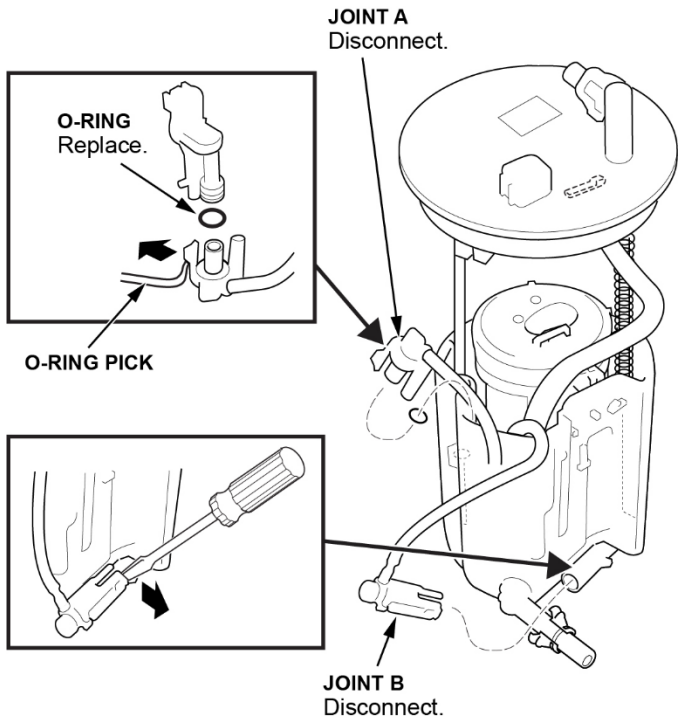

20. Disconnect joint B at the bottom of the reservoir.



21. Remove the fuel filter assembly from the reservoir by releasing the three clips.

**NOTICE**

Do not spread the clips too wide. Spreading them too wide may damage them.

NOTE: The spring may slide off the sliding shaft. Retain this spring. It will be used during assembly.

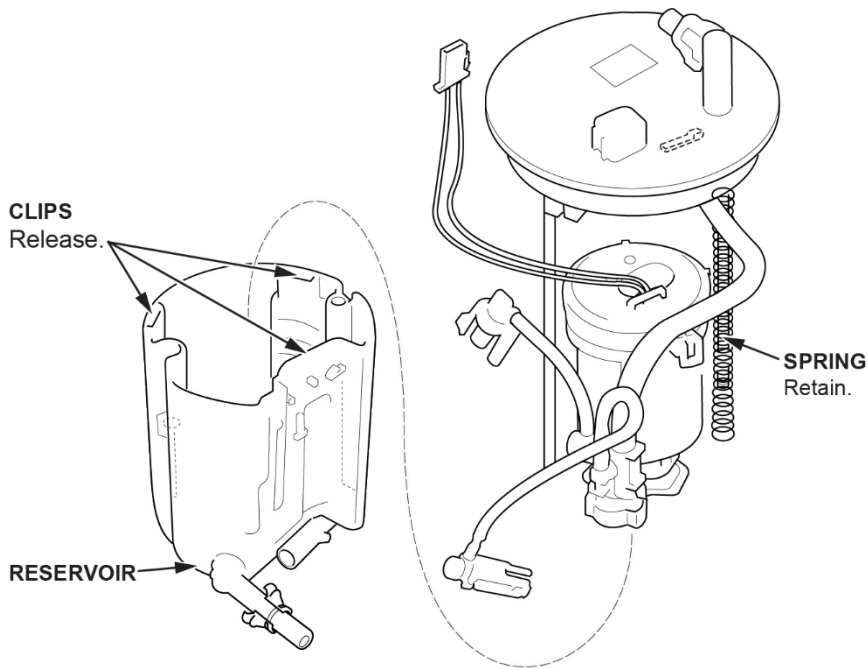

22. Release the three clips at the base of the fuel pump assembly and remove it from the fuel filter.

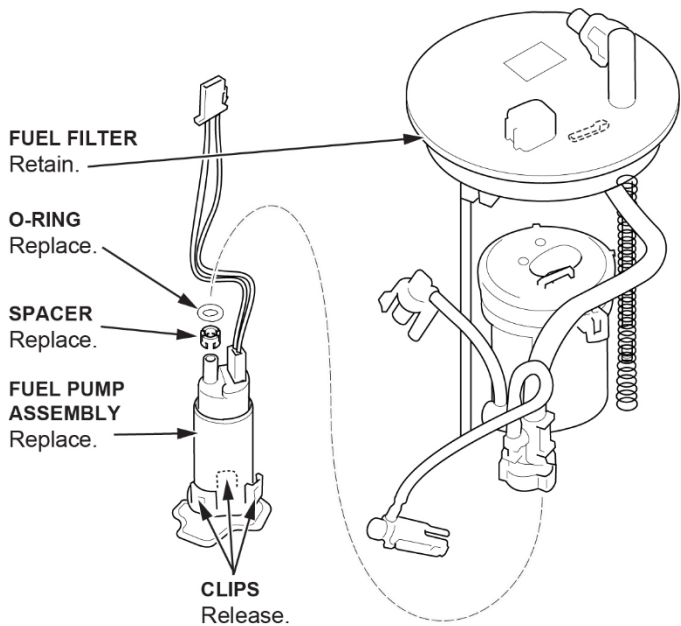

23. Pull the fuel pump assembly out of the fuel filter.

NOTE: If the O-ring remains on the fuel filter, use a flat-tip screwdriver wrapped in protective tape to remove it. Make sure not to damage the O-ring seat section.

24. Install the new spacer on the new fuel pump motor.

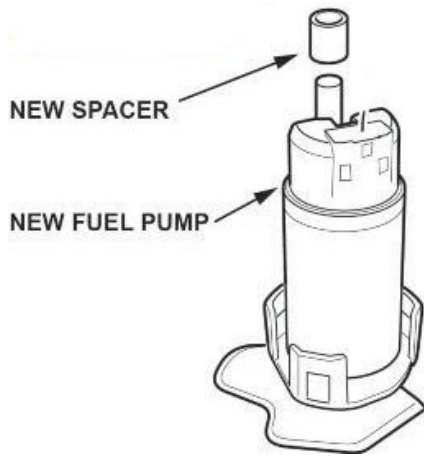

25. Install the new O-ring, then lubricate the outside edge of it, using only clean engine oil.

NOTE: Do not pinch the O-ring during installation.

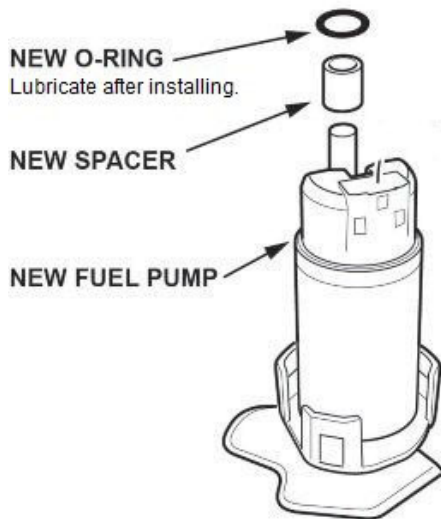

26. Install the new harness and make sure the connection is secure and the connectors are firmly locked into place.

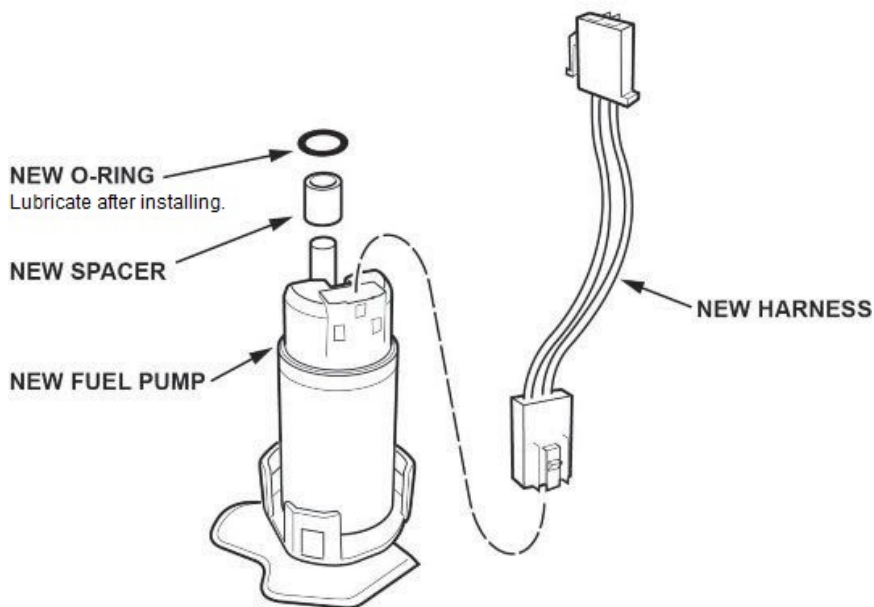

27. Install the fuel pump into the fuel filter.

- Be careful inserting the suction filter so it doesn't break. Use the palm of your hand to push in the entire surface of the suction filter into the module.
- After installing the fuel pump to the strainer, move the lock of the suction filter back and forth to make sure there is no rattling
- If installation with a single push is not accompanied by a click, remove all parts, reset the O-ring, then assemble it again
- The O-ring cannot be reused once assembled. Replace it with a new one, then reassemble
- Be careful that the flange does not hit any other items because this may lead to a fuel leak

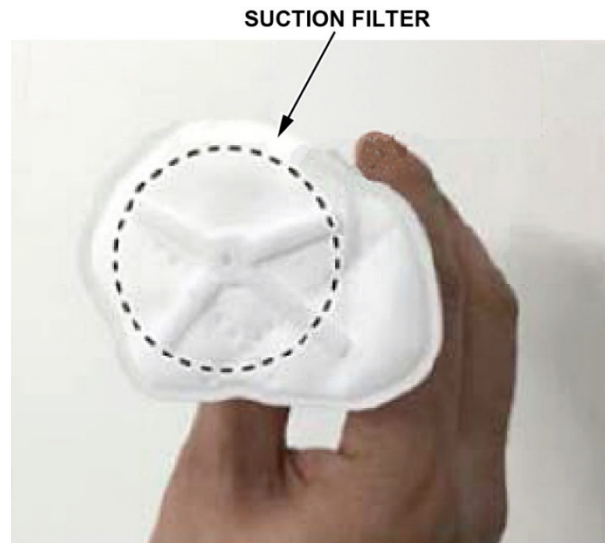

GOOD



NO GOOD

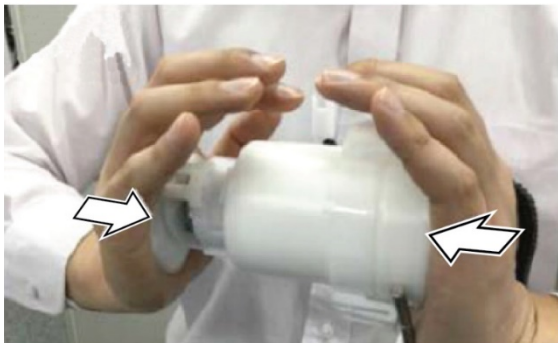

28. Install the fuel filter assembly to the reservoir.

NOTE:

- Insert the spring into the sliding shaft, and make sure it is lined up when installing the fuel filter.
- Make sure the fuel tube is routed **exactly** as shown in the photo taken before disassembly.
- Make sure the three clips are fully engaged.

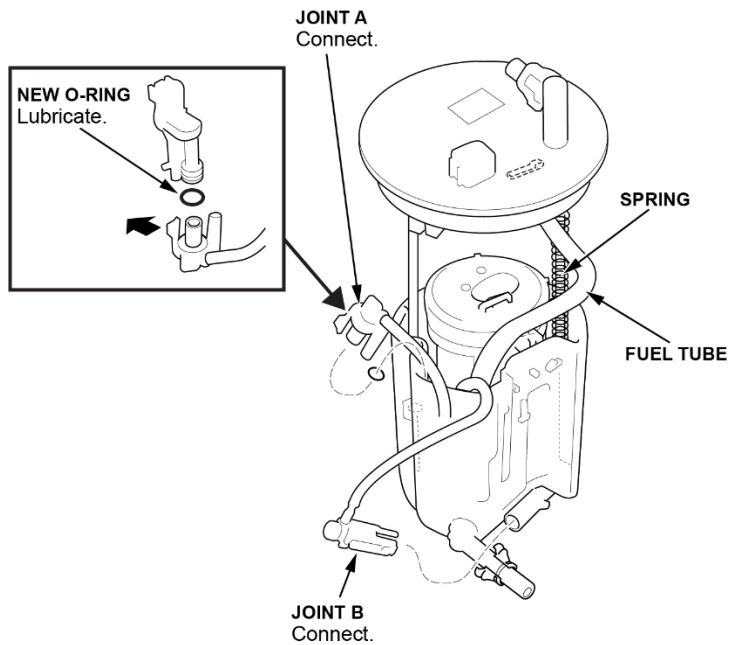

29. Install the new E-rings.

NOTE: After installation, make sure the E-rings can be rotated with your finger. If they cannot be rotated, the E-rings may not be fully seated or may be incorrectly installed.

30. Install the fuel level sensor to the reservoir. Make sure the lock is engaged and the connection is secure.

NOTICE

Do not to bend or twist the fuel level sensor arm excessively. This may damage the fuel level sensor or cause it to send inaccurate readings.

31. Install the wiring harness to the clamps.

**NOTICE**

Do not spread the clamps too wide. Spreading them too wide may damage them.

**NOTE:**

- Clip in the smaller harness wires followed by the larger wires.
- Make sure not to damage the wire harness.
- Make sure to route the wire harness **exactly** as shown in the photo taken before disassembly.

**HARNESS ROUTING:**

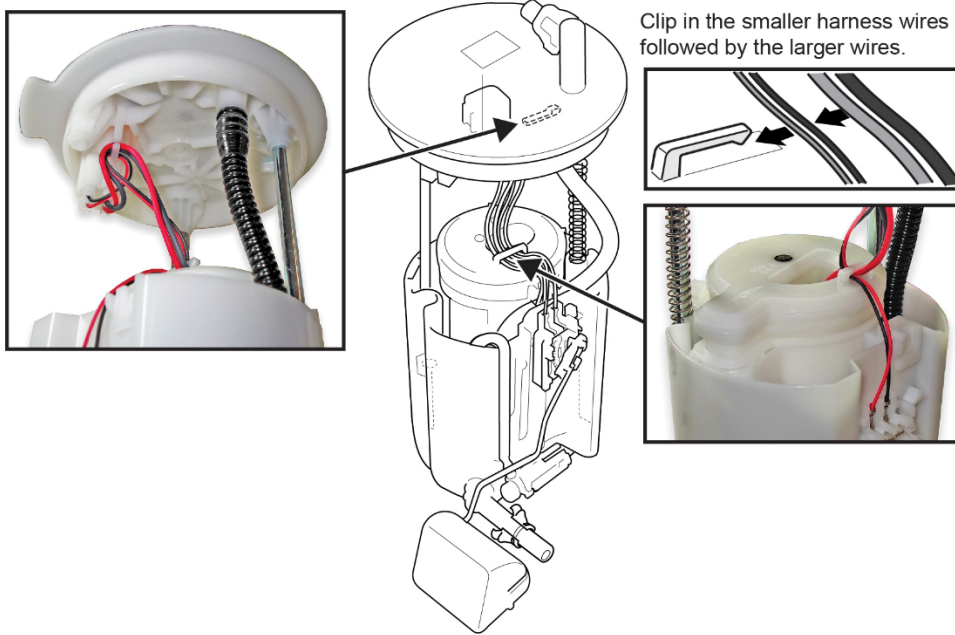

32. While compressing the fuel tank unit, make sure the movement is smooth and the fuel tube and wiring harness do not stretch, pinch, or bind.

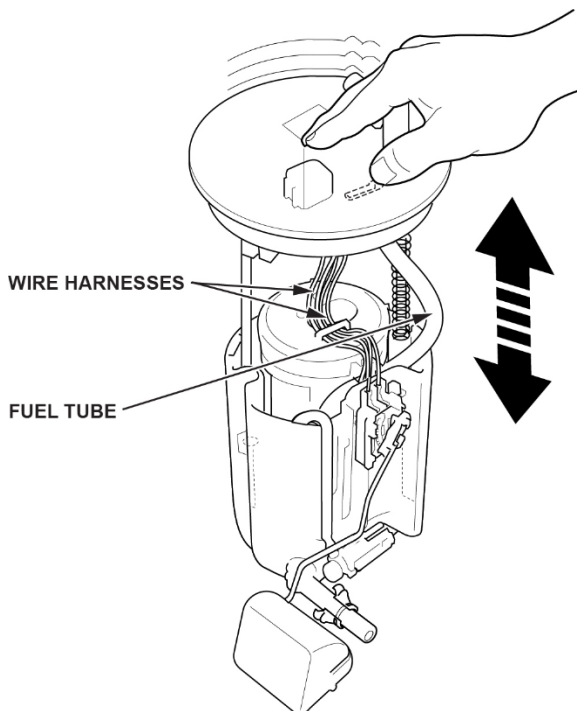

33. Install the new O-ring to the fuel tank, then partially install the new fuel tank unit and connect the transfer pipe quick-connect fitting.

NOTE:

- Be careful not to damage the O-ring.
- Do not coat the O-ring with any oil.

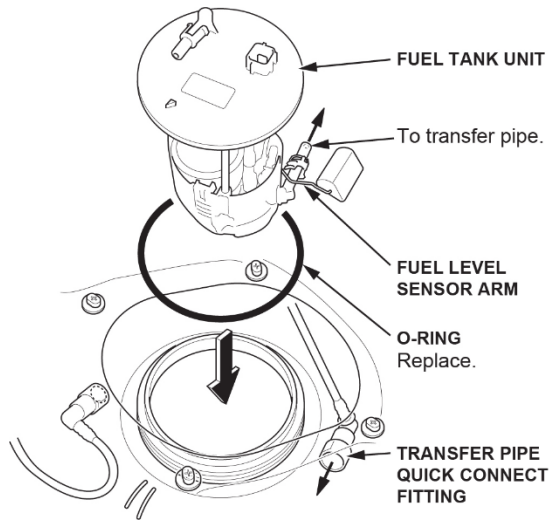

34. Line up the mark on the fuel tank unit to the marks on the fuel tank, then insert the fuel tank unit into the fuel tank.

NOTE: To avoid any leaks, check the O-ring, either visually or by hand, to make sure it is not pinched.

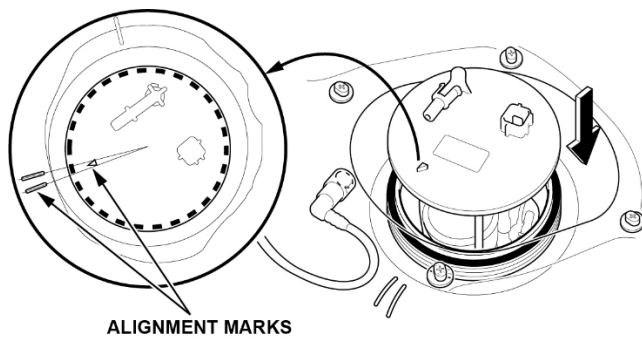

35. Align the mark on the new locknut to the start of the thread on the fuel tank.

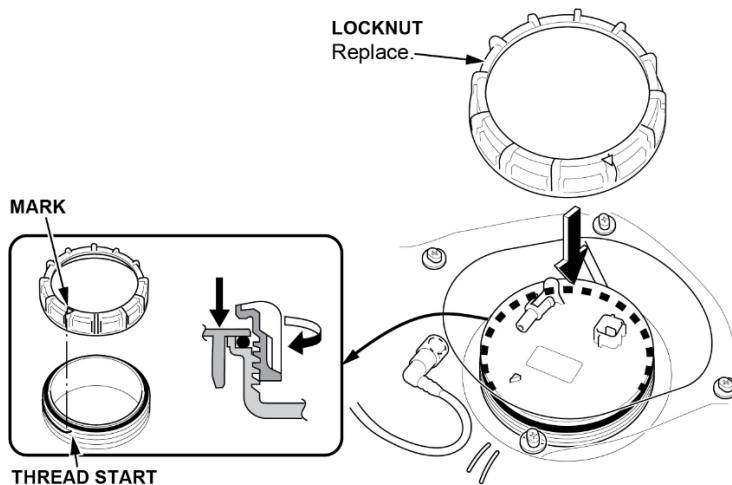

36. Press down on the fuel tank unit while turning the locknut clockwise by hand.

37. Using the fuel nut wrench, tighten the locknut to **100 N·m (74 lb-ft)**.

NOTE:

- During installation, check the O-ring, either visually or by hand, to make sure it is not pinched.
- After tightening, make sure the mark on the fuel tank unit is still lined up with the marks on the fuel tank.

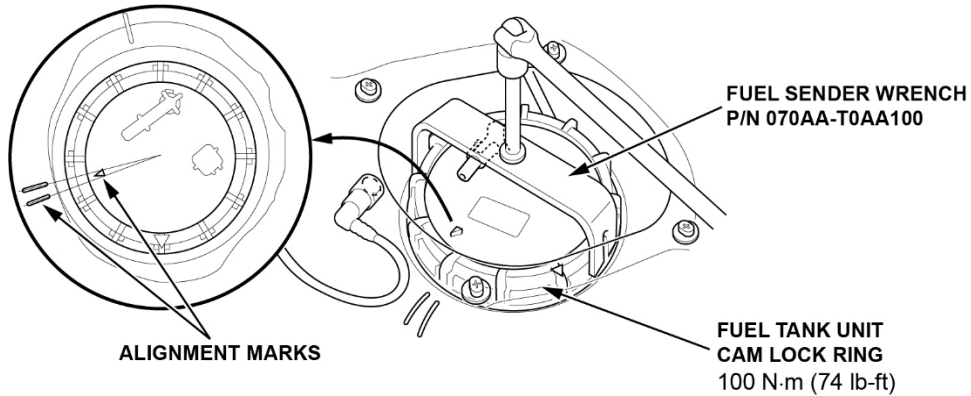

38. Remove the quick-connect fitting retainer from the fuel tank unit, then install a new retainer onto the quick-connect fitting.

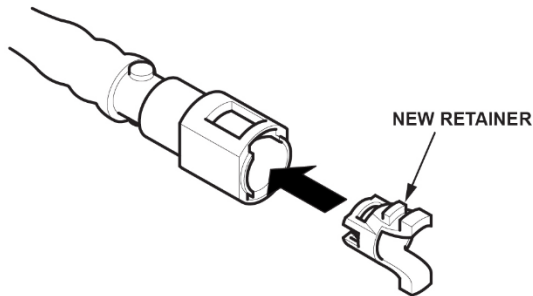

39. Connect the fuel line quick-connect fitting.

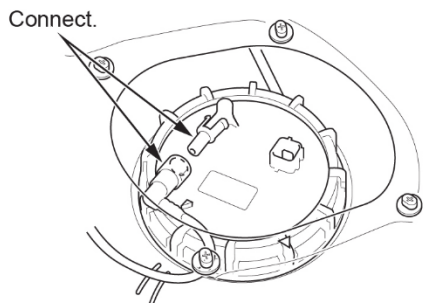

40. Connect the fuel tank unit connector.

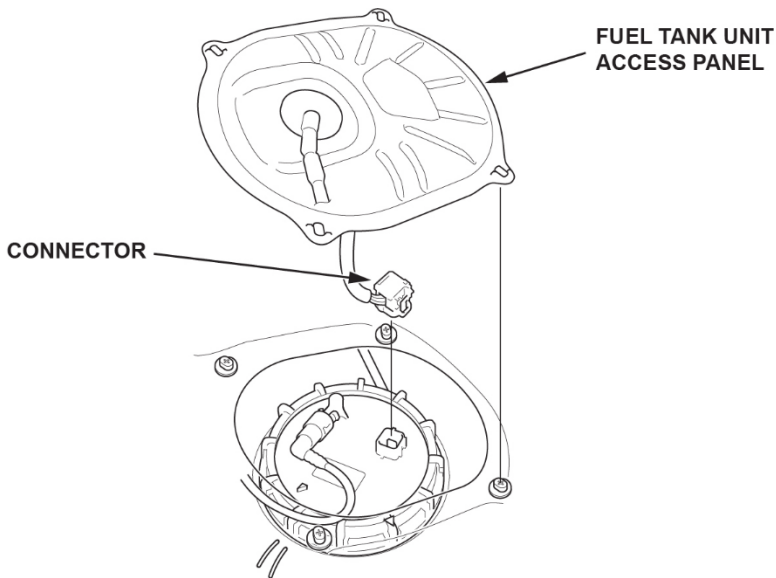

41. Connect the 12-volt battery terminals.

42. Turn the ignition to ON, but do not turn the engine on. After the fuel pump runs for about **2 seconds**, the fuel line will be pressurized. Repeat this two or three times, then make sure there is no fuel leakage.

43. Install the fuel tank unit access panel.

44. Install the remaining parts in the reverse order of removal.

45. Clear all DTCs using an i-HDS.

46. *California residents only:* Fill out a Vehicle Emissions Recall – Proof of Correction certificate, and use **BAS** as the recall number. Have the service consultant give the certificate to your client, and advise him or her to keep it as proof that the recall was completed. Your client will need to submit this certificate to the DMV only if the DMV requests it. If you need more certificates, use reorder number **Y0657**.

Vehicle Emission Recall - Proof of Correction				
License Number	Make	Year Model	Body Type	Vehicle Identification Number
				<input type="text"/>
Manufacturer _____			Recall Number <b>BAS</b>	
The above described vehicle has been repaired, modified and/or equipped with new emission control devices to meet applicable California Emission Control Laws.				
Dealer's Name		Address, City, State and Zip		
Date		Dealership's Authorized Signature		
		X		
Return this certificate to DMV only when required - otherwise retain for your records.				

Y0657 ACL 24832 (0212)

END